

# Roadway Design Manual

**Adopted:** November 3, 1993

**Updated:** March 8, 2023

**Engineering Division**  
2901 W Durango Street  
Phoenix, Arizona 85009

# Table of Contents

Authorization Memorandum

Summary of 2023 Roadway Design Manual Changes

Chapter 1 Introduction

Chapter 2 Transportation Planning

Chapter 3 Environmental Analysis, Clearance and Mitigation

Chapter 4 Design Procedure

Chapter 5 Geometric Design Standards

Chapter 6 Intersections

Chapter 7 Access To Maricopa County Road System

Chapter 8 Bicycle Facility Guidelines


Chapter 9 Landscaping

Chapter 10 Pavement Design Guide



DATE: March 8, 2023

TO: Engineers, Contractors, Consultants, and Agency Staff

FROM: Jesse Gutierrez, P.E.  
Interim Transportation Director <sup>DS</sup>

SUBJECT: 2023 Update to the MCDOT Roadway Design Manual

The effective date for this 2023 update of the Roadway Design Manual shall be March 8, 2023, and the update shall continue in effect thereafter until reissued or updated.

The MCDOT Roadway Design Manual is intended to inform and assist the public, developers, and consultants in the design of MCDOT facilities. Comments and suggestions concerning this manual are welcome. Specific issues, concerns, comments, and suggestions should be addressed to:

MCDOT Engineering Division  
Marty Robbins, Standards and Review  
(602) 506-5356 (email: [Marty.Robbins@Maricopa.gov](mailto:Marty.Robbins@Maricopa.gov))  
or  
Steve Wilcox, Engineering Division Manager  
(602) 506-2400 (email: [Steven.wilcox@maricopa.gov](mailto:Steven.wilcox@maricopa.gov)).

This document is available on the MCDOT website:  
<https://www.maricopa.gov/190/Technical>



## Summary of 2023 Roadway Design Manual Changes

### Chapter 1 Introduction

#### 1.1 Purpose:

7<sup>th</sup> paragraph: Updated division titles.

Added paragraph to state that additional information process regarding the design exception process is provided in the PDM.

### Chapter 2 Transportation Planning

#### 1.1 Purpose:

Table 2.1: Revised Table 2.1

### Chapter 3 Environmental Analysis, Clearance and Mitigation

Originator: Updated division title.

### Chapter 4 Design Procedure

#### 4.3 Construction Drawings

**4.3.2 Drafting Standards.** 4<sup>th</sup> paragraph: Minor text change.

**4.3.6 Face Sheet.** 1<sup>st</sup> paragraph: Minor text change.

**4.3.7 General Notes Sheet.** 1<sup>st</sup> paragraph: Minor text change and added link to the public Road Information tool.

**4.3.8 Quantity Summary Sheet.** 1<sup>st</sup> paragraph: Added link to the bid item master list (BIML)

**4.3.9 Typical Sections.** 2<sup>nd</sup> paragraph: Minor text change added sentence on how to handle variable condition typical sections.

**4.3.10 Geometric Control.** 1<sup>st</sup> paragraph: Remove the requirement to include turned angles and change “dimension” to “label.”

#### **4.3.11 Paving Plan and Profile Sheets.**

Added a paragraph to specify that the dimensions from the construction centerline to the face of curb define the roadway width.

2<sup>nd</sup> paragraph: Minor text change.

3<sup>rd</sup> paragraph: Minor edits.

**4.3.17 Cross Section Sheets.** 1<sup>st</sup> paragraph: Added text to include additional cross sections at intermediate-defined horizontal and vertical deflection points. 3<sup>rd</sup> paragraph: Minor edit.

#### **4.5 Survey and Data Acquisition**

Originator: Updated division title.

**4.5.2 Control Points and Bench Marks.** (A) Definitions 1<sup>st</sup> paragraph: Updated link.

## **4.6 Geotechnical Design**

**Originator:** Updated division title.

## **4.7 Drainage Design**

**4.7.2 Hydraulics.** 4<sup>th</sup> paragraph: Added “riprap and erosion protection” to the list of items to be located outside the clear zone or made traffic safe.

### **4.7.7.1 Culverts.**

Added culvert pipe selection guidelines, methods, and procedures.

Added a paragraph that all pipe culverts shall include an end treatment.

7<sup>th</sup>, 8<sup>th</sup>, 9<sup>th</sup> paragraphs: Deleted.

### **4.7.7.2 Storm Drains.**

Added a paragraph requiring that pipe material for storm drains shall be the same as culverts within County right-of-way.

2<sup>nd</sup> paragraph: Added a requirement that connector pipes shall be RGRCP.

4<sup>th</sup>, 5<sup>th</sup>, 6<sup>th</sup> paragraphs: Deleted.

## **4.12 Traffic Design.**

**Originator:** Updated division title.

2<sup>nd</sup> paragraph: Updated division title.

## **Chapter 5 Geometric Design Standards**

### **5.1 Cross Sedctions**

**Originator:** Updated division title.

### **5.10 Horizontal Curves**

**5.10.4 Superelevation Transitions:** Updated Table 5.6 Design Speed and Relative Profile Gradients to reflect the 2018 AASHTO A Policy on Geometric Design of Highways and Streets, 7th Edition.

### **5.25 Clear Zones**

**5.25.2 Obstacles.** Added Riprap to the list of obstacles.

### **5.35 Pavement Edge Treatments**

**5.35.4 Curb Returns.** 1<sup>st</sup> paragraph: changed Table 6.1 to Table 6.3

## **Chapter 6 Intersections**

### **6.1 General Controls**

**Originator:** Updated division title.

#### **6.1.6 Intersection Lane Requirement:**

1<sup>st</sup> paragraph: Added a statement that turn bay requirements are based on turning movement volumes and take precedence over LOS analysis.

2<sup>nd</sup> paragraph: Revised requirements for when turn lane warrants are met. (A)Right Turn Lane is to be provided when: Changed to (A) Right Turn Lane Warrants: Revised requirements for when right turn lane warrants are met.

Added Table 6.1: Volume Warrants for Right-Turn Lanes.

(B) Left Turn Lane is to be provided when: Changed to (B) Left Turn Lane Warrants: Revised requirements for when left turn lane warrants are met.

Added Table 6.2: Volume Warrants for Left-Turn Lanes.

Added two paragraphs for additional left turn lane requirements.

#### **6.1.7 Intersection Turn Lane Design:**

Added a paragraph to specify additional turn lane design requirements.  
3<sup>rd</sup> paragraph: minor text change.

#### **6.1.12 Intersection Returns:**

1<sup>st</sup> paragraph: Changed Table 6.1 to Table 6.3.

**Table 6.1:** Changed to Table 6.3.

#### **6.1.13 Intersection Sight Distance:**

3<sup>rd</sup> paragraph: Changed Table 6.2 to Table 6.4.

**Table 6.2:** Changed to Table 6.4

### **6.2 Roundabouts**

#### **6.2.4 General Design Criteria:**

1<sup>st</sup> paragraph: Changed Table 6.3 to Table 6.5.

**Table 6.3:** Changed to Table 6.5.

#### **6.2.8.1 Inscribed Circle Diameter (ICD):**

1<sup>st</sup> paragraph: Changed Table 6.3 to Table 6.5.

## **Chapter 7 Access to Maricopa County Roadway System**

### **7.15 Auxiliary Lanes for Driveways**

1<sup>st</sup> paragraph: Added text to specify the types of facilities requiring a warrant study.

#### **7.15.1 Right Turn Lanes**

Rename the section title to “Right Turn Lane Warrants.”

1<sup>st</sup> paragraph: Revised the requirements that need to be met for a driveway right turn deceleration.

2<sup>nd</sup> paragraph: Deleted.

Added Table 7.6 Volume Warrants for Right-Turn Lanes to specify the minimum peak hour right-turn traffic volumes to warrant a right turn.

#### **7.15.2 Left Turn Lanes**

Rename the section title to “Left Turn Lane Warrants.”

1<sup>st</sup> paragraph: Revised the requirements that need to be met for a driveway left turn deceleration.

**Table 7.6:** Changed to Table 7.7.

## **Chapter 8 Bicycle Facilities Guidelines**

### **8.2 Roadway Facility Design Guidelines:**

**Originator:** Updated division title.

#### **8.2.8 Paved Shoulders:**

Change Transportation System Management to Engineering.

### **8.3 Shared Use Path Design Guidelines:**

**Originator:** Updated division title.

## **Chapter 9 Landscaping**

**List of Tables:** Changed first Table 9.1 title and changed second Table 9.1 to Table 9.2.

### **9.1 Landscaping Design:**

**Originator:** Updated division title.

#### **9.2 Design Criteria:**

**Originator:** Updated division title.

##### **9.2.1 Sight Distances, Sight Lines, and Sight Triangles:**

Deleted text “Figure 2 – Unobstructed Open Area For Sight Triangles” and updated figure numbers.

## **Chapter 10 Pavement Design Guide**

### **10.1 Collection of Data**

#### **10.1.1 Office Data**

Changed Roadway Management System (RMS) to Cartegraph Operations Management Software.

##### **10.1.1.1 Roadway Management System (RMS)**

Changed the section title to Cartegraph Operations Management Software and changed the text in the paragraph to reflect Cartegraph.

### **10.1.1.2 Traffic Historical Records**

Revised links.

## **10.2 Pavement Design Procedures**

### **10.2.2.2 Layer Coefficients**

Add note e to specify that the AC mix design shall be per street classification and the AC mix design thickness ratio.

### **10.2.5.2 Testing and Design**

Add a paragraph to specify where to place preservative seal in accordance with Sections 334 and 718.3 of the MAG Uniform Standard Specifications.

## **10.3 Economic Evaluation of Alternative Pavement Design Strategies (Life Cycle Cost Analysis)**

Updated "Prices for Pavement Materials" Table.

### **10.3.1 Example Pavement Design Cost Assessment for Preliminary Pavement Design**

Updated tables.

### **10.3.2 Example Pavement Design Cost Assessment for Final Design**

Updated tables.

# Chapter 1

## Introduction

**TABLE OF CONTENTS**

**CHAPTER 1**

**INTRODUCTION**

**1.1 PURPOSE..... 1-1**

**1.2 APPLICABILITY..... 1-3**

## **1.1 PURPOSE**

The purpose of this manual is to standardize roadway design elements where necessary for consistency and to ensure, as far as is practical, that minimum requirements are met for safety, welfare, convenience, pleasant appearance, environmental sensitivity and economical maintenance.

The standards outlined in this manual cannot apply to all situations. They are intended to assist the professional engineer's competent work but not to substitute for it. Professional engineers are expected to bring the best of their skills and abilities to each project so that it is designed accurately.

Further, these standards are not intended to unreasonably limit any innovative or creative effort that might result in higher quality or increased cost savings for the public. Any proposed departure from these standards will be judged on the basis of whether such a variance will yield a compensating or comparable result that is fully adequate for road users and County residents.

The future traffic characteristics (vehicle types and volumes), roadway functional classification, and topography of the area are the basic criteria used to determine the design standards to be used. The roadway functional classification is to be used to determine the right of way requirements.

Any deviations from these published standards must be approved by the MCDOT (Maricopa County Department of Transportation) Director or an authorized representative before the project design will be considered for approval. All design elements which do not meet these design standards require an approved design exception.

Design exception requests:

- Shall be submitted as a report Signed & Sealed by an Arizona Registered Professional Engineer.
- The design exception request shall:
  - Identify the standard for which a design exception is being requested and explain why the design exception is being requested.
  - Provide a minimum of two design exhibits: one design exhibit shall represent the best design that is fully compliant with existing standards. The second design exhibit shall incorporate the proposed design exception. Additional design exhibits may be required to evaluate other alternatives as requested by MCDOT. All design exhibits shall show all existing conditions. All documentation that may be needed to evaluate the design exception shall be included in the design exception request (e.g., design exhibits, plan views, profiles, details, photos, calculations, location, type of terrain, road classification, current and future traffic volumes, design vehicle, etc.).
  - Evaluate the effects of the design exception on the safety, operation, and maintenance of the facility. Identify how the design exception will impact (increase or decrease) County liability. Identify design features that are included to mitigate the effect of changing the design standard. Identify how the design exception will affect other standards. Include all supporting data:

references, diagrams, design sketches, studies, and agency endorsements that support the design exception.

For MCDOT administered projects, design exception requests shall be submitted to the MCDOT Project Manager for review as described in the Project Development Manual (PDM), Section 2-2.4 Design Exceptions. For all other projects, design exception requests shall be submitted to the Permitting Branch for review. After review of the design exception request for completeness by the Permitting Branch Manager or the MCDOT Project Manager, the request is to be forwarded to the following divisions: Engineering Division, Transportation Systems Management and Operations Division, Roadway Maintenance Division, and the Construction and Materials Division. The Division Managers will provide recommendations to the Director.

A letter of decision for the design exception request will normally be provided within a four week time period. Due to federal review requirements the four week time period does not pertain to design exceptions for federal aid projects or National Highway System (NHS) roads.

When a design exception is granted, the approval letter together with the design exception will be archived and a copy of the approval letter with the design exception will be provided to the Chairman of the Standards Committee.

Developers and their engineering consultants, project designers, and others interested in preparing a design exception request are encouraged to discuss their potential design exception requests with County staff prior to initiating the analysis and documentation effort. This is to enable discussion and determination of the technical and alternatives analysis and associated documentation requirements, and to open communications between County staff and the developer or consultant. Such communication will help to ensure the proposed design will be in the community's best interests.

Additional information regarding the design exception process is provided in Section 2-24 of the MCDOT Project Design Manual (PDM). The MCDOT PDM is located at <https://www.maricopa.gov/DocumentCenter/View/31320/Project-Development-Manual> .

## **1.2 APPLICABILITY**

These standards shall govern all construction and reconstruction of transportation facilities in County right-of-way. They shall also apply to all transportation facilities proposed to be built in right-of-way that is intended to be dedicated to Maricopa County and accepted into the County Road System for maintenance, unless written approval is otherwise obtained from the MCDOT Director or an authorized representative.

Before the County accepts a road for maintenance, it shall meet the standards outlined in this manual. Permitted work shall also conform to the requirements of the current County Resolutions or Ordinances governing permitted work. If noncompliant conditions are found after plan approval, improvements shall be made as necessary to bring the transportation facilities up to these standards prior to acceptance for maintenance. These standards shall be used by private parties, consulting engineers, public utilities, agencies, and MCDOT staff.

The standards apply to rural and urban roadways except for freeways and freeway-type improvements. In these latter cases, the current applicable standards of the Arizona Department of Transportation shall apply.

For the purpose of this manual, the following definitions for maintenance/rehabilitation, roadway betterment, and construction/reconstruction shall be used:

Roadway maintenance/rehabilitation is defined as any work that does not change the geometric prism of the road. Such work will include any surface treatment of the same kind of surface (i.e. addition of gravel to gravel/dirt roads; crack sealing, chip sealing; slurry seal; micro-surfacing; surface recycling, cold mix or hot mix recycling, road mixes or overlays less than or equal to 2½ inches to paved roads; and incidental drainage improvements).

Roadway betterment is defined as a low cost investment in transportation improvements, typically maintenance activities or safety improvements projects that may include pavement widening, resurfacing, grading, guardrail, or bridge repair activities that raise the traffic service level of a road or improves its safety or operating efficiency. Betterment projects costing less than \$300,000 may be funded out of the maintenance/rehabilitation budgets. The objective is to preserve and maintain County roads in a fiscally conservative manner.

Roadway construction and reconstruction is defined as any work that changes the geometric prism or surface type of the roadway. Such work will include roadway widening, penetration and chip seal on existing gravel/dirt surfaces, overlays greater than 2½ inches, and major drainage improvements.

# **Chapter 2**

# **Transportation Planning**

**TABLE OF CONTENTS**

**CHAPTER 2      TRANSPORTATION PLANNING**

**2.1      FUNCTIONAL CLASSIFICATION ..... 2-1**  
    2.1.1 RURAL SYSTEM ..... 2-1  
    2.1.2 URBAN SYSTEM..... 2-3

**2.2      DESIGN HOUR VOLUMES ..... 2-7**  
    2.2.1 DESIGN YEAR ..... 2-7  
    2.2.2 ADJUSTMENTS TO DESIGN YEAR ADT VOLUMES ..... 2-7  
    2.2.3 DESIGN HOUR VOLUME ..... 2-7  
    2.2.4 TURNING MOVEMENT PERCENTAGES ..... 2-8  
    2.2.5 OTHER TRAFFIC VOLUME REDUCTION FACTORS..... 2-8  
    2.2.6 CAPACITY ANALYSIS ..... 2-8  
    2.2.7 FUTURE TRAFFIC VOLUMES ..... 2-9

**2.3      TRAFFIC IMPACT STUDIES ..... 2-10**

**LIST OF TABLES**

TABLE 2.1: ROADWAY PLANNING LEVEL TRAFFIC VOLUMES ..... 2-5

## **2.1 FUNCTIONAL CLASSIFICATION**

### **Originator: Engineering Division**

Functional classification is the process by which roadways are grouped into classes or systems according to the service they provide. The basic functional systems used are parkways, arterials, collectors, and locals. These systems are sub-classified based on the trips served, the areas served, and the operational characteristics of the roadway. Typical cross sections are shown in Chapter 5.

The desired Level of Service (LOS) designations for each roadway section shall be used in traffic analysis to support roadway function classifications, sizing of interim and ultimate roads and determining the number of intersection auxiliary lanes that are required. Roadway Planning Level Traffic Volumes are shown in Table 2.1.

The following is a summary description of LOS is given:

- A - free flow, with low volumes and high speeds.
- B - reasonably free flow, speeds beginning to be restricted by traffic conditions.
- C - stable flow zone, most drivers restricted in freedom to select their own speed.
- D - approaching unstable flow, drivers have little freedom to maneuver.
- E - unstable flow, may be short stoppages.
- F - forced or breakdown flow.

### **2.1.1 RURAL SYSTEM**

#### **2.1.1.1 Rural Parkway** (supplementary to the state freeway and highway systems)

Rural Parkways are roads with the following service characteristics:

- Prohibited left turns
  - in any direction at all intersections.
  - from a side street or driveway onto the Parkway.
- Traffic signals at all intersections operate on a two-phase system.
- Traffic movements suitable for regional and statewide travel.
- Divided roadway, wide median to accommodate U-turn movements.
- Uncurbed
- Desired LOS C.

#### **2.1.1.2 Rural Principal Arterial** (supplementary to the state freeway and expressway system)

Rural Principal Arterials are roads with the following service characteristics:

- Traffic movements
  - With trip length and density suitable for substantial statewide travel.
  - Connects urban areas with populations over 25,000.
- Desired LOS C

### 2.1.1.3 Rural Minor Arterial

Rural Minor Arterials are roads with the following service characteristics:

- Traffic movements
  - with trip length and density suitable for integrated interstate or inter-county service.
  - connects urban areas or other traffic generators with populations less than 25,000.
- Undivided lanes
- Uncurbed
- Desired LOS C.

### 2.1.1.4 Rural Major Collector

Rural Major Collector roads are those with the following service characteristics:

- Traffic movements
  - Trip length and density suitable for inter-county service.
  - Connects traffic generators and larger cities, and traffic generators and routes of a higher classification.
  - Subject to a low level of side friction
    - development may front directly on the road
    - controlled intersection spacing
- Undivided lanes
- Uncurbed
- Desired LOS C.

### 2.1.1.5 Rural Minor Collector

Rural Minor Collector roads are those with the following service characteristics:

- Traffic movements between
  - local roads and arterial/major collector road
  - smaller communities and developed areas
  - locally important traffic generators within their remote regions
- Uncurbed
- Desired LOS B.

### 2.1.1.6 Rural Local Road System (Residential)

Rural Local Roads are those with the following service characteristics:

- Traffic movements
  - between collectors and adjacent lands.
  - involving relatively short distances.
- Uncurbed
- Desired LOS A.

## 2.1.2 URBAN SYSTEM

### 2.1.2.1 Urban Parkway

Urban Parkways are roads with the following service characteristics:

- Prohibited left turns
  - in any direction at all intersections.
  - from a side street or driveway onto the Parkway.
- Traffic signals at all intersections operate on a two-phase system.
- Maximum posted speeds of 45 mph.
- Divided roadway with wide median to accommodate U-turn movements.
- Desired LOS D.

### 2.1.2.2 Urban Principal Arterial

Urban Principal Arterials are roads with the following service characteristics:

- Posted maximum speed of 45 mph
- Divided roadway
- Desired LOS D.

### 2.1.2.3 Urban Minor Arterial

Urban Minor Arterials are roads with the following service characteristics:

- Traffic movements
  - in urban areas consisting of major circulation movements with more emphasis on land access than Urban Principal Arterials.
  - do not penetrate residential neighborhoods.
  - at moderate speeds with partially controlled access facilities.
- Undivided roadway.
- Desired LOS C.

### 2.1.2.4 Urban Collector

Urban Major Collector Roads and Urban Minor Collector Roads are roads with the following service characteristics:

- Traffic movements
  - in urban areas consisting of both land access service and traffic circulation.
  - subject to high levels of median and side friction.
  - penetrate local areas.
    - Development may front directly on the road.
    - Has more than 10 uncontrolled access points per mile on one side.
    - Local areas include residential neighborhoods, commercial, and industrial areas.
- Desired LOS C (Major Collector) and LOS B (Minor Collector).

### 2.1.2.5 Urban Local (Residential)

Urban Local Roads are those with the following service characteristics:

- Traffic movements
  - between adjacent lands and collectors or other roads of higher classification.
  - over relatively short distances,
- Two-lane undivided roadway
- At grade intersections
- Frequent driveway access.
- Desired LOS A.

### 2.1.2.6 Urban Frontage

Urban Frontage Roads are those with the following service characteristics:

- Traffic movements
  - along roads that are generally both parallel to and adjoining arterial streets.
  - collected and dispersed to local streets.

### 2.1.2.7 Cul-De-Sacs and Turnarounds

Cul-de-sacs and Turnarounds are roads with the following service characteristics:

- Traffic movements enter and exit at only one end of the road.
- Traffic movements having a turnaround.

Table 2.1 provides general traffic volumes to achieve the desired LOS for various roadway types. Numbers shown for each level of service are based on Maximum ADT (ADT – Average Daily Traffic, 24 Hour weekday two-way volume) for each level. Volumes shown in the table should not be used to determine roadway classifications. Roadway classifications should be determined primarily by definition and as supported by traffic analysis indicating the desired LOS.

**TABLE 2.1: ROADWAY PLANNING LEVEL TRAFFIC VOLUMES**

Urban Roadway Planning Level Traffic							
Functional Classification	Lanes	Median	LOS B	LOS C	LOS D	LOS E	Peak Hour / ADT% (K)
Parkway	4	Divided	28,500	40,400	50,800	56,400	10
	6	Divided	42,800	60,500	76,400	84,600	
Principal Arterial	2	Undivided	8,800	14,200	15,000	15,900	10
	2	Divided	9,300	15,100	15,900	16,900	
	3	Undivided	14,200	23,200	24,600	25,500	
	3	Divided	15,000	24,700	26,100	27,100	
	4	Undivided	19,500	32,200	34,100	35,000	
	4	Divided	20,700	34,300	36,300	37,200	
	5	Undivided	24,300	40,600	42,800	43,600	
	5	Divided	25,800	43,200	45,600	46,400	
	6	Undivided	29,000	48,900	51,500	52,200	
	6	Divided	30,800	52,000	54,800	55,500	
Minor Arterial	2	Undivided	8,000	12,800	13,500	14,300	10
	2	Divided	8,500	13,600	14,300	15,200	
	3	Undivided	12,800	20,900	22,100	22,900	
	3	Divided	13,600	22,300	23,500	24,400	
	4	Undivided	17,500	29,000	30,700	31,500	
	4	Divided	18,600	30,900	32,700	33,500	
	5	Undivided	21,800	36,500	38,500	39,300	
	5	Divided	23,200	38,900	41,000	41,800	
	6	Undivided	26,100	44,000	46,300	47,000	
	6	Divided	27,800	46,800	49,300	50,000	
Major Collector	2	Undivided	7,400	10,200	12,800	13,400	10
	2	Divided	7,800	10,800	13,600	14,200	
	3	Undivided	12,100	18,300	20,800	21,900	
	3	Divided	12,900	19,400	22,100	23,300	
	4	Undivided	16,800	26,300	28,800	30,400	
	4	Divided	17,900	28,000	30,600	32,300	
	5	Undivided	21,100	33,500	36,200	38,000	
	5	Divided	22,500	35,700	38,500	40,500	
	6	Undivided	25,400	40,800	43,500	45,700	
	6	Divided	27,000	43,400	46,300	48,600	
Minor Collector	2	Undivided	6,700	9,200	11,500	12,100	12
	2	Divided	7,100	9,800	12,200	12,800	
	3	Undivided	8,100	12,600	13,800	14,600	
	3	Divided	11,700	17,500	19,900	21,000	
	4	Undivided	15,200	23,700	25,900	27,400	
	6	Divided	24,300	39,060	41,670	43,740	
Local	2	Undivided	1,500	2,000	2,600	2,700	15

## MCDOT Roadway Design Manual

<b>Rural Roadway Planning Level Traffic</b>							
<b>Functional Classification</b>	<b>Lanes</b>	<b>Median</b>	<b>LOS B</b>	<b>LOS C</b>	<b>LOS D</b>	<b>LOS E</b>	<b>Peak Hour / ADT% (K)</b>
Parkway	4	Divided	23600	36900	47600	54400	8
	6	Divided	35400	55500	71300	81500	
Principal Arterial	2	Undivided	6,700	10,600	11,500	12,000	8
	2	Divided	7,100	11,200	12,200	12,700	
	3	Undivided	10,300	16,800	17,900	18,600	
	3	Divided	11,000	17,800	19,000	19,700	
	4	Undivided	13,900	22,900	24,200	25,100	
	4	Divided	14,800	24,400	25,700	26,700	
	5	Undivided	17,600	28,800	30,400	31,800	
	5	Divided	18,800	30,700	32,300	33,800	
	6	Undivided	21,300	34,700	36,500	38,400	
	6	Divided	22,700	36,900	38,800	40,800	
Minor Arterial	2	Undivided	6,000	9,500	10,400	10,800	8
	2	Divided	6,400	10,100	11,000	11,400	
	3	Undivided	9,300	15,100	16,100	16,700	
	3	Divided	9,900	16,100	17,100	17,700	
	4	Undivided	12,600	20,700	21,700	22,600	
	4	Divided	13,400	22,000	23,100	24,000	
	5	Undivided	15,900	26,000	27,300	28,600	
	5	Divided	16,900	27,600	29,000	30,400	
	6	Undivided	19,200	31,200	32,800	34,500	
	6	Divided	20,400	33,210	34,920	36,720	
Major Collector	2	Undivided	5,600	8,800	9,300	10,000	10
	2	Divided	5,900	9,300	9,900	10,600	
	3	Undivided	8,600	13,800	14,500	15,400	
	3	Divided	9,100	14,600	15,400	16,300	
	4	Undivided	11,500	18,700	19,600	20,700	
	4	Divided	12,200	19,900	20,800	22,000	
	5	Undivided	14,200	23,000	24,100	25,500	
	5	Divided	15,000	24,500	25,600	27,100	
	6	Undivided	16,800	27,300	28,600	30,300	
	6	Divided	17,889	29,000	30,400	32,200	
Minor Collector	2	Undivided	5,000	7,900	8,400	9,000	12
	2	Divided	5,300	8,400	8,900	9,500	
	3	Undivided	5,500	9,000	9,400	9,900	
	3	Divided	8,200	13,200	13,800	14,700	
	4	Undivided	10,300	16,800	17,600	18,600	
	4	Divided	11,000	17,900	18,700	19,800	
Local	2	Undivided	1,100	1,800	1,900	2,000	15

## **2.2 DESIGN HOUR VOLUMES**

### **Originator: Transportation Systems Management & Operations Division**

#### **2.2.1 DESIGN YEAR**

The Design Year for future traffic volumes will be 20-25 years from the start of the design process. This calendar year will be rounded off to the nearest 5-year increment and coincide with a year for which volume projections are available from the Maricopa Association of Governments (MAG). The official MAG traffic volume projection map will be used for a given design year. The Design Engineer will confirm the design year for a project before starting the design process.

#### **2.2.2 ADJUSTMENTS TO DESIGN YEAR ADT VOLUMES**

For some roadway design projects, adjustments will be required to the volumes projected by MAG. Adjustments will be required in anticipation of major land developments or significant changes to nearby roadways that will affect future traffic volumes expected on the roadway under design. Adjustments in traffic volumes for major land developments will follow the MCDOT Traffic Impact Study Manual available on the MCDOT website. Adjustments for other impacts shall be approved by the MCDOT Traffic Engineer before being undertaken by the Design Engineer.

#### **2.2.3 DESIGN HOUR VOLUME**

The Design Hour Volume (DHV) is the traffic volume used to determine the number of traffic lanes needed on the roadway. The DHV is from the Design Year, which shall be approved by MCDOT. The following formula shall be used to determine the DHV:

$$\text{DHV} = \text{ADT} \times \text{K}$$

Where:

DHV = design hour volume of traffic (total, 2-way)

ADT = average 24-hour weekday, 2-way volume of traffic

K = ratio of design hour volume to ADT

(See Table 2.1 for K values to use for rural and urban roadway classifications.)

The number of lanes for each direction of traffic for an interim roadway is determined by the traffic impact analysis. However, the interim roadway shall be designed for conversion to the ultimate section determined by classification.

For special activity centers such as recreational areas, factories, sports arenas, etc., other values of the above factors will be used. It is also recognized that special traffic conditions may or will exist that require modification of the above factors. In these two sets of cases, the different factors must be documented and approved for use by the MCDOT Traffic Engineer.

## **2.2.4 TURNING MOVEMENT PERCENTAGES**

At major intersections and at driveways leading to major activity centers, the design hour turning volumes are important in determining the intersection capacity, resulting number of lanes, and the storage length for exclusive turning lanes required for each approach. For intersections being reconstructed and that are in fully developed areas, existing turning movement percentages will be collected in the field and are assumed to be the same for the future design year. For new intersections or for those significantly impacted by new land developments or major changes to nearby roadways, existing and projected traffic data along with engineering judgment will be used to reassign vehicle trips on nearby street networks to derive the turning movements at project intersections.

Turning movements must be analyzed for both a.m. and p.m. peak hours at project intersections so that the maximum turning or through volumes can be determined for each approach. In the absence of other data, it can generally be assumed that the 'background' street network intersection turning movements will be opposite and equal for the a.m. and p.m. peak hours. In certain areas of the County such as large retirement communities, the peak hours may in fact occur around mid-day rather than at typical morning and evening rush hour periods. Therefore, it is important for the Design Engineer to obtain sufficient existing traffic counts by hourly variation to accurately identify and quantify project intersection turning movement volumes for the design year.

## **2.2.5 OTHER TRAFFIC VOLUME REDUCTION FACTORS**

Vehicle trip (traffic volume) reductions for future transit ridership or other transportation modes are generally not permitted. Reductions for "passer-by or diverted" trips are allowed as per the Institute of Transportation Engineers (ITE) Trip Generation Manual (latest revision) but must first be approved by MCDOT. Trip reductions for special land uses utilizing travel demand management strategies will be considered on a case-by-case basis. However, the factors used must be fully and accurately documented to MCDOT's satisfaction.

## **2.2.6 CAPACITY ANALYSIS**

Software using the current Highway Capacity Manual (HCM) procedures will be used to determine the capacity and resulting number of lanes for roadway design project street sections and intersections. For rural street sections with existing or planned traffic signals more than a mile apart, the appropriate section of the HCM will be used. For urban or suburban areas where traffic signals are at or less than a mile apart, it will be assumed that the signalized intersection capacity will control the design of the roadway segments.

The number of through lanes on street sections must be consistent with the number of through lanes at adjacent intersections. For capacity and lane determination, major intersections are assumed to be signalized for the design year. The signalized intersection section of the HCM will be used for the analysis. The default values of the peak hour factor (PHF), percentage of trucks, and saturation flow rate will be used. Other input criteria will be those equal to existing or future traffic conditions and approved by the MCDOT Traffic Engineer.

### 2.2.7 FUTURE TRAFFIC VOLUMES

Future traffic volumes shall be used to ensure that the road has enough traffic carrying capacity. The general unit of measure for traffic on a road is the ADT, the total volume of traffic in a given time period divided by the number of days in that time period. The future ADT shall be derived from the Maricopa Association of Governments' (MAG) projection model and the engineer's judgement of growth patterns in the area.

The traffic volume during a period of time shorter than a day shall be used for design purposes, reflecting peak hour periods. Reference Table 2.1 for K-values to use for rural and urban roadway classifications. For roads with unusual or highly seasonal fluctuation in traffic volumes, the 30<sup>th</sup> highest hour of the design year should be used.

The directional design hour volume is the traffic volume for the rush hour period in the peak direction of flow. Use directional distribution factors based on existing traffic counts. If this information is not available it should be assumed that 60% of the traffic is going in one direction. Reference Table 2.1 for design volume threshold per hour per lane. For a more detailed analysis of intersection and road capacity, procedures as described in the intersection portion of this manual and the latest version of the HCM should be used.

## **2.3 TRAFFIC IMPACT STUDIES**

### **Originator: Transportation Systems Management & Operations Division**

Traffic impact studies shall be prepared using the procedures outlined in the latest update of the MCDOT Traffic Impact Study Manual available on the MCDOT website.

This policy is to provide for consistency in the preparation of traffic impact studies using certain established criteria. It has been prepared to assist consultants, developers, and others interested in evaluating traffic impacts within MCDOT's jurisdiction. Developers and their engineering consultants are invited to discuss proposed projects with County Staff prior to beginning the analysis. This is to enable discussion and determination of parameters to be used and to open communications between County staff and the developer or consultant. Such communication will help in creating land uses with traffic characteristics that are in the entire community's best interests.

# **Chapter 3**

## **Environmental Analysis, Clearance, and Mitigation**

**TABLE OF CONTENTS**

**CHAPTER 3 ENVIRONMENTAL ANALYSIS, CLEARANCE AND MITIGATION**

3.1 INTRODUCTION ..... 3-1

3.2 ENVIRONMENTAL CLEARANCE AND MITIGATION PROCESS ..... 3-4

3.3 SUMMARY OF THE NEPA CLEARANCE DOCUMENT PROCESS ..... 3-7

3.4 CULTURAL RESOURCES MANAGEMENT..... 3-10

3.5 AIR QUALITY ..... 3-11

3.6 NOISE ..... 3-12

3.7 HAZARDOUS MATERIALS INVESTIGATIONS ..... 3-12

3.8 SECTION 404 PERMIT/SECTION 401 WATER QUALITY CERTIFICATION ... 3-13

3.9 BIOLOGICAL RESOURCES..... 3-13

## **ENVIRONMENTAL CLEARANCE AND MITIGATION**

### **Originator: Engineering Division**

#### **3.1 INTRODUCTION**

The Maricopa County Department of Transportation (MCDOT) takes a proactive approach to environmental compliance, incorporating its Environmental Analysis, Clearance and Mitigation guidelines into the Project Development Process. The environmental clearance process follows two tracks based on funding or federal nexus. The process evaluates a project's potential social, economic, and environmental impacts and is consistent with the processes used by peer agencies. The review, analysis, and development of mitigation, as warranted, are intended to complement the project's development, adhere to relevant laws, regulations, and policy, and serve the public interest. It is a collaborative process designed to minimize project development time and unnecessary rework.

The MCDOT Environmental Clearance Process includes the following steps:

1. Determination of the level of environmental clearance required.
2. Assignment of project to staff or consultant.
3. Coordination and completion of the environmental clearance process.

Key components of the above process include:

- ◇ Review preliminary engineering documents and meet with project engineer.
- ◇ Inventory of project area.
- ◇ Identification of potential impact items.
- ◇ Coordination with other agencies.
- ◇ Prepare supporting environmental documentation.
- ◇ Evaluation of the impacts and development of mitigation.
- ◇ Preparation of appropriate (draft) environmental document.
- ◇ Involve the public, as applicable.
- ◇ Incorporation of comments and reevaluation of the proposal and preparation of final environmental document.

Environmental clearance documents will address each of the following disciplines, as applicable:

#### Socioeconomic Resources

- a. Existing Development and Land Ownership
- b. Planned Development
- c. Displacements
- d. Temporary/Permanent Access Changes
- e. Neighborhood Continuity and Community Cohesion
- f. Title VI/Environmental Justice

#### Natural Environment

- a. Threatened and Endangered Species

- b. Federal Sensitive Species/Habitat
- c. Tribal Sensitive Species/Habitat
- d. Arizona Species of Concern/Habitat
- e. Native Plants
- f. Invasive Species
- g. Other Wildlife and Habitat Concerns
- h. Invasive Plant Species
- i. Wetland and Riparian Areas
- j. 100-Year Floodplain and Impacts
- k. Clean Water Act Sections 404/401
- l. Arizona/National Pollutant Discharge Elimination System (Clean Water Act Section 402)
- m. Navigable Waters
- n. Prime or Unique Farmlands
- o. Farmland of Statewide or Local Importance

### Visual Impacts

- a. Change in Visual Character
- b. Land Management Agency Visual Objectives
- c. Scenic Roadway/Byway

### Physical/Construction

- a. Construction-related Impacts
- b. Utility Impacts
- c. Hazardous Materials Evaluation
- d. Noise Impacts
- e. Air Quality Impacts

### Cultural Resources

- a. Archaeological and Historic Resources

### Section 4(f)/6(f) Resources

- a. Section 4(f) Wildlife/Waterfowl
- b. Section 4(f) Historic Site
- c. Section 4(f) Park/Recreational Site
- d. Section 6(f) Park/Recreational Site

Each MCDOT Transportation Improvement Program (TIP) project will be evaluated for potential social, economic, and environmental impacts that could result from its construction and operation and documented. There are several levels of environmental documentation. The level required depends on several factors, including the project's complexity, potential environmental impact, funding source, and jurisdiction of the right-of-way.

MCDOT projects without a major federal nexus or projects that are not federally funded are addressed using MCDOT's Environmental Determination Report (EDR) with mitigation measures documented in an Environmental Clearance Memo. These projects can range from major projects (e.g., new alignments, capacity improvements, bridges/drainage structures) to minor projects (e.g., adding shoulders, intersection improvements, and safety enhancements). Some of the smaller

projects may be addressed using MCDOT's Environmental Identification (EID) document rather than the EDR, but will also document mitigation measures/requirements in an Environmental Clearance Memo. Projects that require other types of federal approvals or permits (e.g., Endangered Species Act Section 7 consultation, Clean Water Act permitting), may require additional analysis and documentation required by the federal agency with jurisdiction.

MCDOT projects with federal funding or other major federal nexus shall comply with the National Environmental Policy Act (NEPA) and associated guidelines. For these projects, a Categorical Exclusion (CE), an Environmental Assessment (EA), or an Environmental Impact Statement (EIS) will be prepared. The Arizona Department of Transportation (ADOT) Environmental Planning Group and the Federal Highway Administration (FHWA) shall determine the level of environmental documentation and shall review and approve MCDOT projects subject to federal funding. The non-federally funded projects with a federal nexus shall be directed by the federal agency involved in the project.

Though most MCDOT projects are constructed with Highway User Revenue Funds and do not require compliance with NEPA, all MCDOT projects will adhere to the Environmental Compliance and Mitigation Process described as follows. The Environmental Clearance and Mitigation Process is conducted concurrently with the preparation of Scoping Reports and Final Design.

## **3.2 ENVIRONMENTAL CLEARANCE AND MITIGATION PROCESS**

The following is a “stepped” process to provide timely action and a level of effort commensurate with the degree of potential impact. Figure 1, Environmental Mitigation “Future State” Process, provides a flow chart outlining the activities. The steps noted below correspond to Figure 1.

### **Step 1.0**

The Project Manager holds a Project Work Plan Meeting to obtain input from the Environmental Program Branch (and other disciplines) on Project Team, Scope, Schedule, and Budget.

### **Step 2.0**

The Project Review Committee approves the project for Scoping.

### **Step 3.0**

The Environmental Program Branch provides environmental information to the Project Manager to incorporate into the Scoping Report. The information provided would be in the form of an Environmental Identification (EID), and Environmental Identification Memo (EIM), or a simple write up if the project is federally funded (so that the Environmental Program Branch can focus on the clearance aspect for federally funded projects). This information involves a preliminary review of the social, economic, and environmental resources that could be affected by the project, and identifies project or study area conditions that could constitute a NEPA federal nexus or that would require other federal approvals. The review is based on known, published, or readily available data sources and a windshield survey of the project limits. It addresses natural resources (e.g., habitat, water courses), social resources (e.g., schools, parks, residential areas, population demographics), and socioeconomic resources (e.g., land use, commercial development) present in the study area.

### **Step 4.0**

The Project Manager holds a Meeting to obtain input from the Environmental Program Branch (and other disciplines) regarding Project Team, Scope, Schedule, and Budget to assist the Project Manager in creating the Project Work Plan.

### **Step 5.0**

The Project Review Committee approves the project for Final Design. If there is a NEPA federal nexus, the project must adhere to the NEPA process and proceeds to Step 6.1/Step 6.2. If there is no federal nexus but a project has the potential for major environmental issues (e.g., relocations, land use changes, Clean Water Act permitting, controversy), proceed to Step 6.1/Step 6.2. If there is no NEPA federal nexus and no major environmental issues, the project would proceed to Step 6.0.

In addition to the process outlined in Figure 1, for projects requiring federal permits or consultation with federal agencies, any analysis and documentation required as part of the permit or consultation process will need to be completed in support of the federal agency’s review and approval.

### **Step 6.0**

The Environmental Program Branch conducts analysis of potential impacts or issues as recommended in Step 3.0. MCDOT’s Environmental Documentation and Clearance Memo with Mitigation Measures are prepared. The Environmental Clearance Memo is sent to the Project

Manager, Utility Coordinator, the Construction Manager/Chief Construction Engineer, the Project Management Branch Manager, and the Engineering Assistant Division Manager.

### **Step 6.1/Step 6.2**

For federally funded projects, the NEPA process is administered through the ADOT Local Government Section and the FHWA. If the project is not funded by the FHWA but is on federal land (e.g., U.S. Department of Agriculture Forest Service, U.S. Department of the Interior Bureau of Land Management, or U.S. Department of the Interior Bureau of Indian Affairs), the NEPA process is then guided by that federal agency. In all cases, an early meeting with the lead federal agency and key regulatory agencies will occur to coordinate technical reports and roles and responsibilities and to outline the process to be followed. The Environmental Program Branch will facilitate the meeting(s). *NOTE: Complex projects also follow Step 6.1/Step 6.2. See above for some examples of complex projects.*

### **Step 7.0/Step 8.0**

The Project Manager includes the mitigation measures/Environmental Clearance Memo in the project plans or special provisions, and the Engineering Division Manager signs off on the project, after consulting with the Environmental Program Branch Manager.

### **Step 9.0**

The Project Manager notifies the Environmental Program Branch of Construction Hand-off Schedule.

### **Step 10.0**

The Construction Manager/Chief Construction Engineer and/or MCDOT Resident Engineer assigned to the project meet with the Environmental Program Branch to develop the implementation plan for the mitigation measures.

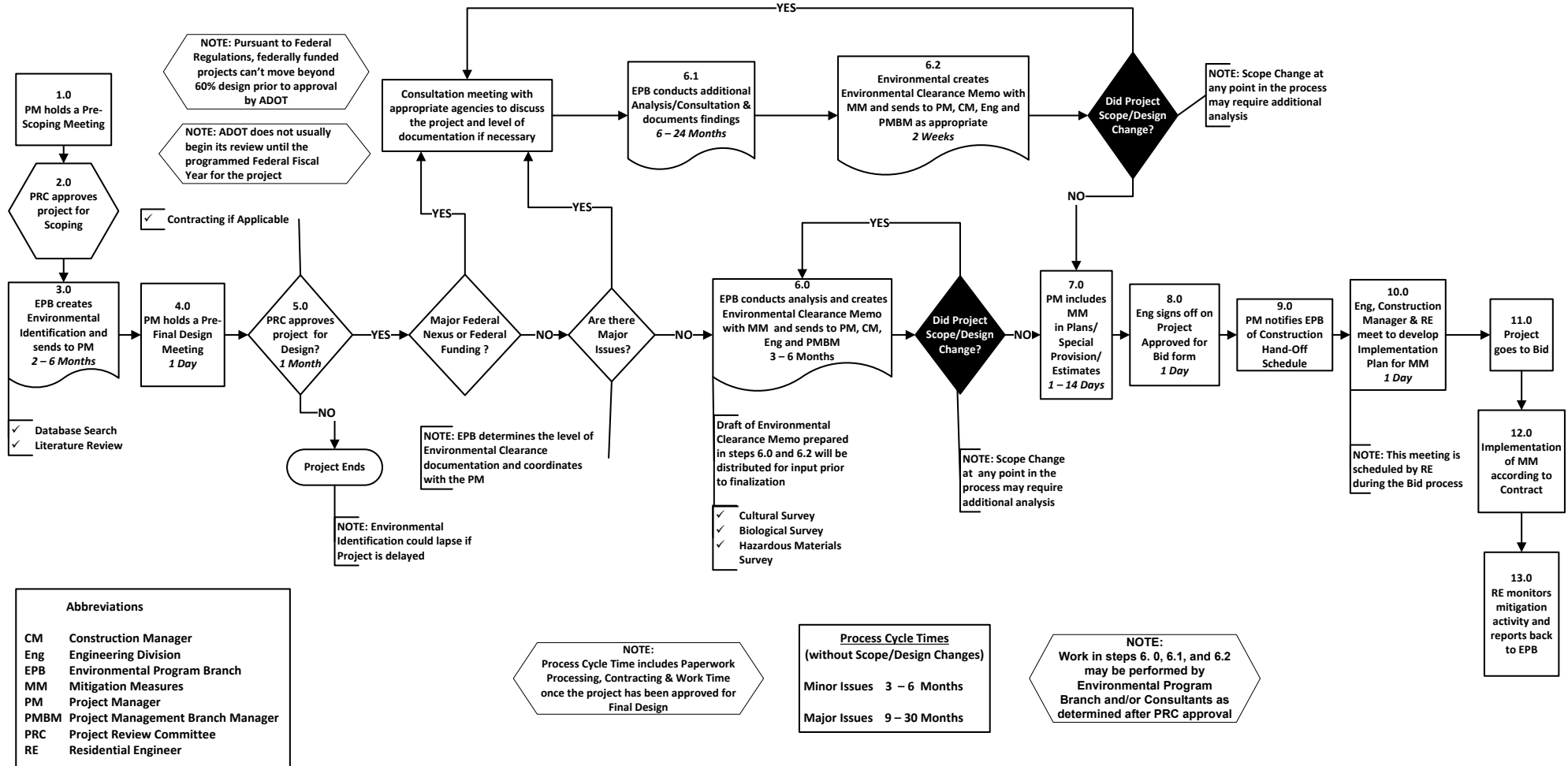
### **Step 11.0/Step 12.0**

The project is bid and the contractor/MCDOT implement mitigation measures, as applicable.

### **Step 13.0**

The MCDOT Resident Engineer monitors the mitigation activities to verify that the measures were applied in accordance with the contract documents and reported back to the Environmental Program Branch. As needed, continuing/ongoing maintenance of mitigation measures is applied by the appropriate party (e.g., the contractor, the Roadway Maintenance Division).

## MCDOT ENVIRONMENTAL CLEARANCE AND MITIGATION PROCESS



### **3.3 SUMMARY OF THE NEPA CLEARANCE DOCUMENT PROCESS**

#### **A. ENVIRONMENTAL SCOPING**

Scoping is the process of identifying a project’s potential social, economic, and environmental impacts based on site visits and coordination with other affected or interested agencies and the general public. Project scoping begins during the early project development phase and may continue through the design phase.

#### **B. CATEGORICAL EXCLUSION (CE)**

CEs are project actions that do not significantly affect the environment individually or cumulatively and are excluded from the EA or EIS process. CE documents are only prepared for projects with a significant federal nexus or projects with federal funding. There are two groups of CEs:

A specific list of actions that typically qualify under the first group of CEs are described in 23 CFR 771.117(c), and are therefore known as “c-list” CEs. This list of actions does not require further NEPA documentation. “c-list” CEs normally can be cleared by ADOT and do not require formal approval or review by the FHWA.

The most common utilized c-list CEs from 23 CFR 771.117 by MCDOT are listed below:

#### **23 CFR 771.117(c)**

- (c)(1) Activities which do not involve or lead directly to construction, such as planning and research activities; grants for training; engineering to define the elements of a proposed action or alternatives.
- (c)(3) Construction of bicycle and pedestrian lanes, paths, and facilities.
- (c)(7) Landscaping.
- (c)(8) Installation of fencing, signs, pavement markings, small passenger shelters, traffic signals, and railroad warning devices where no substantial land acquisition or traffic disruption will occur.
- (c)(9) Emergency repairs under 23 U.S.C. 125 damaged by an incident resulting in an emergency declared by the Governor of the State and concurred in by the Secretary, or a disaster or emergency declared by the President.
- (c)(21) Deployment of electronics, photonics, communications, or information processing used singly or in combination, or as components of a fully integrated system, to improve the efficiency or safety of a surface transportation system.
- (c)(22) Projects, as defined in 23 U.S.C. 101 that would take place entirely within the existing operational right-of-way. Existing operational right-of-way refers to right-of-way that has been disturbed for an existing transportation facility.
- (c)(23) Federally-funded projects: (i) That receive less than \$5,000,000 of Federal funds; or (ii) With a total estimated cost of not more than \$30,000,000 and Federal funds comprising less than 15 percent of the total estimated project cost.
- (c)(24) Localized geotechnical and other investigation to provide information for preliminary design and for environmental analyses and permitting purposes, such as drilling test bores for soil sampling; archeological investigations.
- (c)(25) Environmental restoration and pollution abatement actions to minimize or mitigate the impacts of any existing transportation facility (including retrofitting and construction of stormwater treatment systems) to meet Federal and State requirements.

(c)(26) Modernization of a highway by resurfacing, restoration, rehabilitation, reconstruction, adding shoulders, or adding auxiliary lanes if the action meets the constraints in paragraph (e) of 23 CFR 771.117.

(c)(27) Highway safety or traffic operations improvement projects, including the installation of ramp metering control devices and lighting, if the project meets the constraints in paragraph (e) of 23 CFR 771.117.

(c)(28) Bridge rehabilitation, reconstruction, or replacement or the construction of grade separation to replace existing at-grade railroad crossings, if the actions meet the constraints in paragraph (e) of 23 CFR 771.117.

A separate list of actions that typically qualify under the second group of CEs are described in 23 CFR 771.117(d), and are therefore known as “d-list” CEs. These are projects typically requiring additional documentation beyond the level of a “c-list” CE. These projects have a higher potential for environmental impacts, while still meeting the criteria of a CE. If there are no unusual circumstances resulting in significant impacts and there are no “Threshold Criteria” exceeded, the project can be approved as a “d-list” CE by ADOT. For projects with adverse impacts or in which any of the “Threshold Criteria” is exceeded, the CE must be approved by FHWA.

The most utilized d-list CEs from 23 CFR 771.117 are listed below:

**23 CFR 771.117(d)**

(d)(6) Approvals for disposal of excess right-of-way or for joint or limited use of right-of-way, where the proposed use does not have significant adverse impacts.

(d)(12) Acquisition of land for hardship or protective purposes. Hardship and protective buying will be permitted only for a particular parcel or a limited number of parcels. These types of land acquisition qualify for a CE only where the acquisition will not limit the evaluation of alternatives, including shifts in alignment for planned construction projects, which may be required in the NEPA process. No project development on such land may proceed until the NEPA process has been completed.

(i) Hardship acquisition is early acquisition of property by the applicant at the property owner's request to alleviate particular hardship to the owner, in contrast to others, because of an inability to sell his property. This is justified when the property owner can document on the basis of health, safety or financial reasons that remaining in the property poses an undue hardship compared to others.

(ii) Protective acquisition is done to prevent imminent development of a parcel which may be needed for a proposed transportation corridor or site. Documentation must clearly demonstrate that development of the land would preclude future transportation use and that such development is imminent. Advance acquisition is not permitted for the sole purpose of reducing the cost of property for a proposed project.

(d)(13) Actions described in paragraphs (c)(26), (c)(27), and (c)(28) of 23 CFR 771.117 that do not meet the constraints in paragraph (e) of 23 CFR 771.117.

## **B.1 CATEGORICAL EXCLUSION ENVIRONMENTAL COMMITMENTS**

An Environmental Commitments Memo is a document detailing the mitigation measures, permits, and guidelines required to be implemented or followed in order for the project to remain compliant and remain categorically excluded from further NEPA compliance documentation.

## **C. ENVIRONMENTAL ASSESSMENT**

An EA is prepared for actions not covered under a CE that do not clearly require preparation of an EIS. Upon completion of an EA, the environmental process either culminates with the issuance of a Finding of No Significant Impact (FONSI) or it is demonstrated that preparation of an EIS is warranted and the EIS process is initiated.

The EA defines the scope of the proposed action, determines which aspects of the proposed action have potential for environmental impact, identifies measures and alternatives that might mitigate adverse environmental impacts, and specifies other environmental review and consultation requirements to be prepared concurrently with the EA. A formal public hearing (or public hearing offer) must be completed prior to preparing the Final EA. For federally funded projects, the EA is prepared under the direction of MCDOT in consultation with ADOT and the FHWA.

### **C.1 FINDING OF NO SIGNIFICANT IMPACT**

A FONSI documents why the proposed action will have no significant environmental impacts. A FONSI is usually attached to an EA and supports the decision that no EIS is needed. (A FONSI is not a decision document but is a “finding” or a “conclusion.”)

## **D. ENVIRONMENTAL IMPACT STATEMENT**

An EIS is an interdisciplinary document that identifies and thoroughly analyzes any significant, social, economic, and/or environmental impacts that might be caused by implementing any one of a range of responsible alternatives, including the proposed action.

An EIS is prepared only when it has been determined that other types of NEPA compliance documentation are not applicable. A public hearing and a formal review process are required in an EIS. An EIS is not a decision document but one upon which decisions are based. For federally funded projects, the EIS is prepared under the direction of MCDOT in consultation with ADOT and the FHWA.

### **D.1 NOTICE OF INTENT**

At the outset of the process, a Notice of Intent (NOI) is published in the Federal Register. The NOI describes the proposed action and the probable alternatives and identifies anticipated issues.

### **D.2 NOTICE OF AVAILABILITY**

A Notice of Availability must be published in the Federal Register and/or in local and state newspapers stating that a draft EIS is available for public review and comment.

### **D.3 RECORD OF DECISION**

A Record of Decision (ROD) registers the decision on an EIS. The ROD explains the decision, describes the other alternatives, and specifies which alternatives were environmentally preferred. The ROD indicates any special consideration of national policy and whether practical means have been adopted to avoid or minimize environmental harm

by implementing the selected alternative. Any monitoring program essential for mitigation is also described.

## E. MITIGATION

Mitigation is a commitment to a specific action that will alleviate or eliminate identified environmental impacts. The mitigation measures contained in a CE, an EA, or an EIS are commitments and must be implemented. Mitigation is intended to:

1. Avoid impacts by taking certain action.
2. Minimize impacts by limiting the degree of action.
3. Rectify the impacts by repair or rehabilitation.
4. Reduce or eliminate impacts over time by preservation and maintenance operations.
5. Compensate for the impacts by substituting resources or environments.

If monitoring is necessary to evaluate the effectiveness of any mitigation measure, a monitoring plan must be included in the CE, Finding of No Significant Impact (EA), or ROD (EIS). (Occasionally, mitigation measures may simply be “See Standard Specifications” or “See Construction Special Provisions.”)

## **3.4 CULTURAL RESOURCES MANAGEMENT**

The following Cultural Resources Management Process will be undertaken for MCDOT TIP projects and may be required of the general public or other agencies seeking to make improvements in Maricopa County right-of-way. In general, the MCDOT Cultural Resources Management Process will consist of the following components:

1. Environmental determination of the scope of the action and the level of response required (see Step 3.0).
2. Identification of participants or interested parties who will interact with MCDOT in the Cultural Resources Management Process, and formulation of negotiated action plans or federal or state agreement documents (e.g., Programmatic Agreement, Memorandum of Agreement, Memorandum of Understanding) detailing how consultation and mitigative activities will be structured.
3. Diligent execution of all required actions to complete the process in a professional, timely, and cost-effective manner.

Key components of the process include:

- ◇ Identification of the undertaking.
- ◇ Identification of project area/construction area boundaries.
- ◇ Identification of all historic properties that have the potential to be disturbed as a result of the undertaking through a review of the AZSITE database and the preparation of a Class I Inventory/Records Review report.
- ◇ Determination of the need for a Class III cultural resource survey and report.
- ◇ Identification of all impacts to significant State or National Register-eligible historic properties or traditional cultural properties.

- ◇ Proactive consultation with the Arizona State Museum; the State Historic Preservation Office; the Advisory Council on Historic Preservation; federal, state and local governments; Tribal governments or communities; and all interested parties.
- ◇ Diligent execution of appropriate site avoidance or mitigation measures as determined by the consultation process.
- ◇ Professional documentation and information management.
- ◇ Public outreach/communication, including project enhancement grantsmanship, avocational/volunteer participation, educational advocacy services, and forthright information disclosure to the public and media organizations.

Though many persons will contribute to the management process, a designated staff specialist within the MCDOT Environmental Program Branch will serve as lead administrative manager for all collateral issues in the MCDOT Cultural Resource Management Process.

### **3.5 AIR QUALITY**

MCDOT projects shall be designed to comply with provisions of the Clean Air Act. Attainment requirements were established by the 1977 Clean Air Act Amendments (CAAA) and strengthened substantially by the 1990 CAAA. The U.S. Environmental Protection Agency designated the metropolitan area within Maricopa County as a non-attainment area for three pollutants: carbon monoxide, ozone, and particulate matter. For each of these three pollutants, the Clean Air Act further classifies non-attainment areas by the extent to which the pollutant level in the ambient air exceeds adopted federal standards. The specific terms used in this classification system are marginal, moderate, serious, severe, and extreme. The stringency of legally required control measures used to improve the air quality of non-attainment areas depends on this classification. The Environmental Program Branch will periodically monitor the status of the region's air quality status to determine if actions are required on a project basis. Non-attainment status must be verified at the time of project design.

The State and County air quality control plans require that carbon monoxide, particulate, and volatile organic carbon (hydrocarbon) emissions from all sources be controlled with best available control measures. For road construction, this specifically applies to earthmoving, material stockpiles, and dust control. Earthmoving permits are required for all construction activities.

If air quality modeling is required for a project, all of the information used for traffic analysis will be required, along with information on traffic signal phasing and timing, the planned cross-section, and details of existing residences. Also needed is a detailed description of any planned multi-modal transportation facilities included in the development plan. A micro-scale analysis will be performed if the project uses federal funds and includes any arterial or higher-class roads or if determined necessary by MCDOT. The model CAL3HQC or equivalent shall be utilized. All arterial class road projects adding ½ mile or more of additional through lane capacity must have a conformity determination completed no earlier than 3 years before construction and no later than the date of the final construction permit.

The Maricopa County Air Quality Department's regulations establish air quality permitting requirements. MCDOT will determine the air quality impacts of the project on the transportation network and include that determination as part of the environmental determination.

### **3.6 NOISE**

MCDOT projects without federal funding will comply with requirements of the MCDOT Noise Abatement For Roadway Projects Policy, April 2019. Projects that will use federal funding for construction will comply with the ADOT Noise Abatement Requirements, May 2017. This includes related provisions of U.S. Title 23, Code of Federal Regulations Part 772 (23 CFR 772), Procedures for Abatement of Highway Traffic Noise and Construction Noise.

ADOT and MCDOT have separate noise abatement policies that are tailored to the types of highways and roadways each respective department maintains. Both policies comply with 23 CFR 772.

If noise impact modeling is required for a project, all of the information used for traffic analysis will be required, along with the planned cross-section and details of existing residences. Peak-hour traffic analysis and traffic classification are essential. A micro-scale noise impact analysis will be performed if the project adds through-lane capacity and there are existing residences that may incur noise impacts, at the time the project is funded, or if determined necessary by MCDOT. Project modeling shall be done with an FHWA-approved model. For further information, contact the Environmental Program Branch.

MCDOT adopted a Noise Abatement For Roadway Projects in April 2019. This policy gives guidance for interpretation of 23 CFR 772 for local conditions and guidance for modeling input. This policy, including all revisions thereto, will be the basis for MCDOT to determine the noise impacts of the project on the transportation network and include that determination as part of the environmental determination, unless the funding source of a project requires that other policies, such as those of ADOT, be used.

### **3.7 HAZARDOUS MATERIALS INVESTIGATIONS**

As part of the environmental clearance process, the Environmental Program Branch will attempt to identify potentially hazardous materials and/or underground storage tanks in the project area. This will occur during Step 6.0. Based on a visual review of adjacent land uses and businesses that have the potential for use, generation, or disposal of hazardous materials, a recommendation for further action will be made if needed. If the project has the potential to encounter contamination or would acquire new right-of-way at the suspect site(s), a regulatory records review and preparation of a Preliminary Initial Site Assessment will occur (Step 6.0/6.1 of Figure 1). The results will be documented in the proper environmental document (EID, EDR, CE, EA, or EIS). Any necessary mitigation measures would be listed in the Environmental Clearance Memo.

If hazardous materials are identified, or the potential for hazardous materials is perceived, then surface and subsurface investigations may be conducted by a consultant to determine the extent of contamination (Step 6.1 of Figure 1). The need for further investigation and/or mitigation will be determined through consultation between the Environmental Program Branch, party performing the survey/investigation, and the project engineer.

In compliance with the Occupational Safety and Health Act (29 U.S. Code 651), MCDOT will investigate whether asbestos-containing materials are present in structures subject to removal or modification. Additionally, painted surfaces, including but not limited to bridge structures,

railings, poles, and pavement markings will be tested for the presence of lead-based paint if the features are to be demolished or modified or if pavement markings are to be removed. If the testing results in positive readings, the appropriate mitigation measures for workplace and public safety will be incorporated.

### **3.8 SECTION 404 PERMIT/SECTION 401 WATER QUALITY CERTIFICATION**

All projects that will require construction activity within a “water of the United States” must be reviewed in accordance with Section 404 of the Clean Water Act. Waters of the United States include all rivers, washes, drainages, ponds, etc., whether they have permanent water or not. The primary concern regarding waters of the United States is that if any “fill material” will be placed or “dredging activity” will occur (permanent or temporary) in an area under jurisdiction of the U.S. Army Corps of Engineers, then a Section 404 permit will be needed prior to construction.

For MCDOT TIP projects, the Environmental Program Branch is responsible for acquiring the appropriate permit from the U.S. Army Corps of Engineers. Section 404 permits will be secured during the environmental clearance process. Application for the appropriate Section 404 permit will be submitted between 60 percent and 95 percent plans and approval, and preferably prior to completion of 100 percent design.

Two types of Section 404 permits are available to meet the criteria of the Clean Water Act: nationwide permits and individual permits. A series of nationwide permits are used for smaller projects and require less time and effort to obtain. These permits can generally be acquired in 2 to 6 months. Individual permits are required for all projects where none of the nationwide permits are applicable; individual permits typically require 9 to 12 months to acquire.

In conjunction with the Section 404 permit, Section 401 Water Quality Certification will be coordinated with the Arizona Department of Environmental Quality (for Tribal lands, however, the U.S. Environmental Protection Agency is responsible for Section 401 certification). This coordination addresses water pollution prevention relative to project construction activities.

### **3.9 BIOLOGICAL RESOURCES**

All projects with the potential to affect natural biological resources or projects that may encounter protected or endangered plant or animal species will be reviewed by the Environmental Program Branch. The Arizona Game and Fish Department On-Line Environmental Review Tool will be accessed to determine the potential presence of protected, candidate, or species of concern and their habitat. If protected species are likely to be present, the Environmental Program Branch will prepare a Biological Evaluation to determine the likelihood of impacts and will recommend avoidance or mitigation measures. If impacts to Endangered Species Act species cannot be avoided, consultation with the U.S. Fish and Wildlife Service is required whether or not the project is federally funded or has a federal nexus. The analysis would occur during Step 6.0/Step 6.1.

# **Chapter 4**

## **Design Procedure**

TABLE OF CONTENTS

CHAPTER 4 DESIGN PROCEDURE

**4.1 BASIC CRITERIA ..... 4-1**

4.1.1 ROAD CLASSIFICATION ..... 4-1

4.1.2 DESIGN VEHICLE ..... 4-1

4.1.3 DESIGN FOR FUTURE TRAFFIC VOLUMES ..... 4-1

4.1.4 TOPOGRAPHY ..... 4-1

4.1.5 DEVELOPMENT OF PLANS AND SPECIFICATIONS ..... 4-2

4.1.6 PARK ROAD SYSTEM STANDARDS ..... 4-3

4.1.7 ALTERNATIVE MULTI-MODAL CROSSINGS ..... 4-3

4.1.8 TIME LIMITATION OF APPROVAL ..... 4-3

**4.2 SUBMITTAL REQUIREMENTS AND FORMAT ..... 4-4**

4.2.1 SUBMITTAL AND REVIEW ..... 4-4

4.2.2 DESIGN AND DRAFTING FORMAT ..... 4-4

**4.3 CONSTRUCTION DRAWINGS ..... 4-5**

4.3.1 GEOGRAPHIC ORIENTATION OF PLAN SHEETS ..... 4-5

4.3.2 DRAFTING STANDARDS ..... 4-5

4.3.3 STANDARD SHEETS ..... 4-5

4.3.4 BASE MAP INFORMATION ..... 4-5

4.3.5 CONSTRUCTION NOTES ..... 4-6

4.3.6 FACE SHEET ..... 4-7

4.3.7 GENERAL NOTES SHEET ..... 4-7

4.3.8 QUANTITY SUMMARY SHEET ..... 4-8

4.3.9 TYPICAL SECTIONS ..... 4-8

4.3.10 GEOMETRIC CONTROL ..... 4-9

4.3.11 PAVING PLAN AND PROFILE SHEETS ..... 4-9

4.3.12 STORM DRAIN PROFILE SHEETS ..... 4-10

4.3.13 SPECIAL DETAILS AND OTHER AUXILIARY SHEETS ..... 4-11

4.3.14 SIGNING, PAVEMENT MARKINGS, AND SIGNAL SHEETS ..... 4-11

4.3.15 REFERENCE DRAWINGS ..... 4-11

4.3.16 MASS DIAGRAM ..... 4-11

4.3.17 CROSS SECTION SHEETS ..... 4-11

**4.4 SPECIAL PROVISIONS AND ENGINEER’S ESTIMATE ..... 4-13**

4.4.1 CONSTRUCTION SPECIFICATIONS ..... 4-13

4.4.2 ENGINEER’S ESTIMATE ..... 4-13

**4.5 SURVEY AND DATA ACQUISITION ..... 4-14**

4.5.1 COORDINATE SYSTEM - DATUMS ..... 4-14

4.5.2 CONTROL POINTS AND BENCH MARKS ..... 4-16

4.5.3 DATA COLLECTION ..... 4-17

4.5.4 PUBLIC LAND CORNERS, PROPERTY, AND RIGHT-OF-WAY  
MONUMENTS ..... 4-17

4.5.5 TOPOGRAPHICAL FEATURES (FOR BASE MAP GENERATION) ..... 4-18

4.5.6 DRAWING GENERATION (SURVEY MAPS) ..... 4-19

4.5.7	PHOTOGRAPHS .....	4-20
4.5.8	DELIVERABLES.....	4-20
<b>4.6</b>	<b>GEOTECHNICAL DESIGN .....</b>	<b>4-22</b>
4.6.1	GENERAL .....	4-22
4.6.2	FIELD EXPLORATIONS AND TESTS .....	4-22
4.6.3	ANALYSIS AND REPORT .....	4-23
4.6.4	SOIL PARAMETERS FOR TRENCH SHORING DESIGN .....	4-24
4.6.5	PAVEMENT DESIGN .....	4-24
4.6.6	BORROW MATERIAL .....	4-24
4.6.7	SUBMITTALS .....	4-24
<b>4.7</b>	<b>DRAINAGE DESIGN .....</b>	<b>4-25</b>
4.7.1	GENERAL REQUIREMENTS .....	4-25
4.7.2	HYDRAULICS.....	4-25
4.7.3	BRIDGES .....	4-26
4.7.4	PAVEMENT DRAINAGE.....	4-27
4.7.5	STORM DRAIN DESIGN .....	4-27
4.7.6	DRAINAGE REPORT REQUIREMENTS .....	4-28
4.7.7	ASSORTED DRAINAGE DESIGN REQUIREMENTS .....	4-31
4.7.7.1	Culverts.....	4-32
4.7.7.2	Storm Drains .....	4-33
4.7.7.3	Valley Gutters .....	4-33
<b>4.8</b>	<b>BRIDGE DESIGN .....</b>	<b>4-34</b>
4.8.1	DESIGN PARAMETERS .....	4-34
4.8.2	UTILITY ACCOMMODATIONS .....	4-34
4.8.3	REQUIRED DESIGN DOCUMENTS.....	4-35
4.8.4	CONSTRUCTION PLANS .....	4-35
4.8.5	SUBMITTAL REQUIREMENTS AND PROCEDURES .....	4-36
4.8.5.1	Maricopa County Contracted Work.....	4-36
4.8.5.2	Permit Work (Not Maricopa County Contracted Work) .....	4-36
<b>4.9</b>	<b>HAZARDOUS MATERIALS.....</b>	<b>4-37</b>
<b>4.10</b>	<b>RIGHT-OF-WAY .....</b>	<b>4-38</b>
<b>4.11</b>	<b>UTILITIES AND IRRIGATION .....</b>	<b>4-39</b>
4.11.1	IRRIGATION FACILITIES.....	4-39
4.11.2	UTILITIES.....	4-39
4.11.3	COORDINATION WITH UTILITIES AND MUNICIPALITIES.....	4-41
<b>4.12</b>	<b>TRAFFIC DESIGN .....</b>	<b>4-42</b>
<b>4.13</b>	<b>EARTHWORK .....</b>	<b>4-43</b>

**LIST OF TABLES**

TABLE 4.1: MINIMUM COVER DEPTH FOR UNDERGROUND UTILITIES .....	4-40
--	------

## **4.1 BASIC CRITERIA**

### **Originator: Engineering Division**

#### **4.1.1 ROAD CLASSIFICATION**

The road classification shall be as shown in the Functional Classification Map of the Transportation System Plan 2040. If the classification is not identified, the Design Engineer must submit a classification for approval.

#### **4.1.2 DESIGN VEHICLE**

The design vehicle is the largest vehicle likely to use the road with considerable frequency or a vehicle with special characteristics that must be considered in designing the road. The design vehicle will affect the radii at intersections and the radii of turning roadways. It will also affect the climbing lane requirements on two lane roads. Unless otherwise specified, all roadways and intersections will be designed to accommodate a WB-50 design vehicle as defined in the 2004 5<sup>th</sup> edition of the AASHTO publication A Policy on Geometric Design of Highways. Other design vehicles shall be as defined in the most current edition of the AASHTO publication A Policy on Geometric Design of Highways.

#### **4.1.3 DESIGN FOR FUTURE TRAFFIC VOLUMES**

The primary design consideration for roadways is the handling of vehicular traffic. When streets are built or reconstructed, they will be designed with sufficient traffic handling capacity to accommodate the future level of traffic volumes. Section 2.2 Design Hour Volumes and the MCDOT Traffic Impact Procedures describe in greater detail the procedure to be followed in determining the capacity of roadways and intersections used in the design process.

While the functional classification approved for a roadway will govern the basic cross sectional elements, additional through or left turn lanes, auxiliary right turn lanes, acceleration lanes, and similar design features may be required. MCDOT may direct the designer to do a detailed capacity analysis to determine the need for additional or auxiliary lanes.

#### **4.1.4 TOPOGRAPHY**

The topography of the area shall be determined by a site visit and available topographic maps. The terrain shall be classified as level, rolling, or mountainous. Level terrain is when highway sight distances are or could be made adequate without major construction requirements. This generally includes short grades of no more than 1 or 2 percent. Rolling terrain is when natural slopes consistently rise and fall with grades of up to 6.0% for lengths of 700 feet. Mountainous terrain is when changes in the ground's elevation with respect to a road are abrupt. Mountainous terrain has greater than 15% slopes on the U.S.G.S. 7.5-Minute Series Maps.

#### 4.1.5 DEVELOPMENT OF PLANS AND SPECIFICATIONS

Project design and construction, unless otherwise indicated, shall be in accordance with the latest edition and the most current revision of the following publications:

- ◇ Maricopa Association of Governments Uniform Standard Specifications and Details for Public Works Construction as distributed by the Maricopa Association of Governments (MAG).
- ◇ Maricopa County Department of Transportation Supplement to the Maricopa Association of Governments Uniform Standard Specifications and Details.
- ◇ Maricopa County Resolutions for Work in Dedicated Maricopa County Right-of-Way.
- ◇ Manual on Uniform Traffic Control Devices for Streets and Highways as distributed by the U.S. Department of Transportation, Federal Highway Administration, as amended and approved by the Arizona Department of Transportation.
- ◇ A Policy on Geometric Design of Highways and Streets as distributed by the American Association of State Highway and Transportation Officials (AASHTO).
- ◇ Roadside Design Guide as distributed by the American Association of State Highway and Transportation Officials (AASHTO).
- ◇ Highway Capacity Manual and the current Highway Capacity Software, as distributed by the Transportation Research Board.
- ◇ Roundabouts: An Informational Guide, Second Edition, Transportation Research Board (TRB), National Cooperative Highway Research Program (NCHRP) Report 672, research sponsored by AASHTO in cooperation with the U.S. Department of Transportation, Federal Highway Administration.
- ◇ Materials Preliminary Engineering and Design Manual, Third Edition, March 1989, with current revisions, as distributed by the Arizona Department of Transportation.
- ◇ Arizona Department of Transportation Pavement Design Guide
- ◇ MCDOT Interim Mechanistic-Empirical (ME) Flexible Pavement Design Guide
- ◇ Drainage Policies and Standards for Maricopa County, Arizona, adopted by the Maricopa County Board of Supervisors.
- ◇ Drainage Design Manual for Maricopa County Hydrology, as distributed by the Flood Control District of Maricopa County.
- ◇ Drainage Design Manual for Maricopa County Hydraulics, as distributed by the Flood Control District of Maricopa County.
- ◇ Drainage Design Manual for Maricopa County Erosion Control, as distributed by the Flood Control District of Maricopa County.
- ◇ Stormwater Compliance Requirements and Recommended Procedures for Construction and Maintenance Activities as published by the Maricopa County Department of Transportation.
- ◇ AASHTO LRFD Bridge Design Specifications as published by the American Association of State Highway and Transportation Officials
- ◇ Manual for Condition Evaluation of Bridges as distributed by American Association of State Highway and Transportation Officials (AASHTO).
- ◇ Standard Specifications for Structural Supports for Highway Signs, Luminaires and Traffic Signals as published by American Association of State Highway and Transportation Officials (AASHTO).
- ◇ CADD Standards as published by the Maricopa County Department of Transportation.

- ◇ Information Guide for Roadway Lighting as distributed by the American Association of State Highway and Transportation Officials (AASHTO).
- ◇ Guide for the Development of Bicycle Facilities, as distributed by AASHTO.
- ◇ MCDOT Traffic Impact Procedures.
- ◇ MCDOT Pavement Marking Manual.
- ◇ MCDOT Traffic Signing Manual.
- ◇ MCDOT Traffic Signal Design Manual.
- ◇ MCDOT ADA Compliance Guidelines.
- ◇ MCDOT Earthwork Guidelines.
- ◇ Maricopa County Regional Trail System Plan
- ◇ MAG Regional Off-Street System Plan
- ◇ Designing Walkable Urban Thoroughfares: A Context Sensitive Approach, Institute of Transportation Engineers (ITE)
- ◇ Urban Bikeway Design Guide, National Association of City Transportation Officials (NACTO)

#### **4.1.6 PARK ROAD SYSTEM STANDARDS**

For design information related to the development of public roads within the Maricopa County Park system, the design should consist of elements in the most recent edition of the following publications:

- ◇ Standards for Maricopa County Parks Roadway System
- ◇ Standards for Lake Pleasant Regional Park Roadway System

#### **4.1.7 ALTERNATIVE MULTI-MODAL CROSSINGS**

Where the Maricopa County Regional Trail System intersects with county roadways, MCDOT will have trail crossings incorporated into the design and construction of the roadways. MCDOT will consider all trails, shared use paths, and other multimodal facilities proposed by developers or other agencies in the design and construction of roadways. The type of crossing will be determined on a case-by-case basis. Grade separated intersections at major road crossings should be considered whenever feasible. Guidelines for crossings will comply with the latest edition of the AASHTO Guide to the Development of Bicycle Facilities, the MAG Regional Off-Street System Plan, the Maricopa County Regional Trail System Plan, or other agreed upon national or local design guidelines or standards.

#### **4.1.8 TIME LIMITATION OF APPROVAL**

The County approval of road construction plans shall be valid for a time period of one (1) year. Plans not under construction within this time period are to be resubmitted and approved by the County prior to construction.

## **4.2 SUBMITTAL REQUIREMENTS AND FORMAT**

### **Originator: Engineering Division**

#### **4.2.1 SUBMITTAL AND REVIEW**

Construction plans submitted for review shall be accompanied by an Engineer's Estimate of Construction Cost (Section 4.4.2) together with special provisions, appropriate design calculations, estimated earthwork quantities, drainage and geotechnical reports, and other items as may be required. Professional documents such as the drainage report, geotechnical report, and specifications shall be signed and sealed by a qualified registrant of the Arizona State Board of Technical Registration.

Projects to be constructed under a MCDOT permit by private parties or other public agencies shall comply with the then current adopted resolution or ordinance to work in the right of way and this Roadway Design Manual. Submitted construction documents shall require compliance with the Maricopa Association of Governments (MAG) Uniform Standard Specifications and Details for Public Works Construction as modified by the MCDOT Supplement to the MAG Uniform Standard Specifications and Details. The professional registrant's seal on construction documents submitted for permit review shall be dated on or after the effective date identified by the authorization memorandum of the most current MCDOT Supplement to the MAG Uniform Standard Specifications and Details for Public Works Construction.

For MCDOT Transportation Improvement Program (TIP) projects, a detailed scope of work will be prepared by MCDOT. The scope of work will guide the designer in developing design documents. Submittal requirements for County contracted design shall be identified in the design contract. Electronic files shall be included with all submittals. Refer to the Project Development Manual (PDM) for additional guidance.

#### **4.2.2 DESIGN AND DRAFTING FORMAT**

Plans shall be prepared in accordance with current MCDOT design and drafting standards.

The preparation of plans for construction under a Maricopa County permit may be hand or CAD drawn and shall be prepared in basic agreement with the Maricopa County Department of Transportation Drafting Guidelines and Section 4.3 Construction Drawings.

MicroStation software shall be used to generate all MCDOT TIP project drawings in accordance with Maricopa County Department of Transportation CADD Standards.

InRoads software shall be used to generate designs for all MCDOT TIP projects in accordance with Maricopa County Department of Transportation CADD Standards.

## **4.3 CONSTRUCTION DRAWINGS**

### **Originator: Engineering Division**

#### **4.3.1 GEOGRAPHIC ORIENTATION OF PLAN SHEETS**

Plan sheets will be oriented in such a way that 'north' is to the top or to the right of the drawing. Roadway stationing shall always increase from left to right on the drawings.

#### **4.3.2 DRAFTING STANDARDS**

MCDOT drafting guidelines (sample plans) are not to be used as a substitute for design criteria, technical assistance, or sound engineering judgment. MCDOT approved symbols and abbreviations shall be used. MAG Detail 110 PLAN SYMBOLS are MCDOT approved. Additional project specific symbols and abbreviations shall be added into a legend or table by the designer.

All construction drawings are to be drawn to scale and the scale is to be identified graphically and by notation. MCDOT makes extensive use of reduced plan sets. Half-size plans shall be scalable and fit on ledger (11"x17") size paper. Plans not capable of being produced as high quality prints in reduced format will be considered unacceptable and shall be redrawn by the Design Engineer.

A north arrow shall be included with all area plan views to show plan orientation, this includes but is not limited to vicinity maps, key maps, geometric control sheets, plan sheets, and details.

Final plans shall be sealed by an Arizona professional registrant. Plans shall be submitted both electronically in PDF format and as full size hard copy drawings. Drawings shall be photo reproducible.

#### **4.3.3 STANDARD SHEETS**

MCDOT TIP projects are to comply with CADD Standards and the drafting guideline sheets. Full size standard sheets shall be 22" x 34".

For permit work submitted plan sheets shall not exceed 24" x 36" and are to be neat, clear, legible, and complete in all respects.

CADD Standards and Example Plan Sheets can be found at the following link:

<https://www.maricopa.gov/3580/CADD-Standards>

#### **4.3.4 BASE MAP INFORMATION**

The Design Engineer shall conduct a field review with the survey topographic drawings to ensure general conformance with existing conditions noting any discrepancies such as existing features that are not shown and shown features that are not present. The Design Engineer shall have discrepancies corrected. The Design Engineer is responsible for the base maps used for the

construction documents. Survey topographic information is used to create base maps. When the depiction of information on survey topographic drawings differs from that required on base maps, the Design Engineer is responsible for making base map adjustments. For example a survey drawing may define a culvert by a single line connecting the culvert inlet and outlet, the Design Engineer is to show the culvert's width to scale with the culvert size, material, and invert elevations identified on the base map. Contour mapping from the survey topographic drawings shall be displayed on base maps; the Design Engineer is to ensure that the contour interval and elevations are clearly identified.

The Design Engineer shall research materials such as record drawings (as-built plans), utility plans, and other data and show pertinent information on the drawings. Base maps shall show all existing utility lines and have the conduit size and material identified. All fire hydrants, valves, manholes, meters, etc. are to be shown connected to the appropriate facility. Existing culverts and utility conduits greater than 12 inches in width are to be shown to scale. Elevations are to be shown for manhole rims and inverts, culvert inverts, etc. When two or more utility owners have the same type of facility within the project limits, identify on the plans the owner associated with each installation.

Identify the governing jurisdiction; this will usually be Maricopa County. Show and dimension other jurisdictional boundaries that are within or adjacent to the project.

Existing right-of-way and easements lines are to be shown, labeled, and dimensioned.

Topography beyond the limits of the project shall be shown on project plans in accordance with sound engineering judgment to allow for appropriate project reviews by MCDOT. Base mapping is to include existing contours, elevations, and the existing surface material of all connecting roadways and driveways.

#### **4.3.5 CONSTRUCTION NOTES**

The Design Engineer shall prepare notes to ensure clarity and prevent confusion or misunderstanding during construction. Notes shall be clearly worded and symbols shall be consistent throughout the plan sheet(s). Traffic signal information, irrigation, storm drains, intersection staking diagrams, and other items that appear on more than one sheet shall be cross-referenced.

Construction & Removal Notes are to contain the following items:

- Location – identify station and offset OR station to station limits. Location requirement may be omitted from the note if shown on the plans.
- Type of work – usually Construct, Install, Remove, or Relocate.
- Item being installed or constructed – Pay item description and quantity. If the work item does not have a specific corresponding pay item do not show a quantity.

Relocation Notes are to identify:

- Location – final location of the relocated item.
- Reference standard details or special details required for the installation at the relocated position.

#### 4.3.6 FACE SHEET

The face sheet shall contain the project name, county map, vicinity map, key map, and locations for as-built indexing. When needed for clarity the vicinity map and/or key map information may be placed on multiple sheets.

Vicinity Map shall pictorially show the project limits relative to section, township and range boundaries and show the local road network adjacent to the project area. The names of major area features such as railroads, canals, and arterial roads shall be identified. The names of adjacent minor roads and intersecting roads shall be identified when feasible. The vicinity map is to show access to the project area from the adjacent surrounding arterial or section line roads. Show the adjacent local road network in sufficient detail and with sufficient area of coverage to determine potential access impacts from traffic restrictions or closures within the project area.

The Key Map is a graphical location index for various sheet types contained within the project plans. It shall show the project area with sheet numbers and boundaries identified. The sheet numbers are to be the numerical sequential number representing the sequential location within the project plan set. Common sheet types to be shown on the key map include: paving plan and profile, storm drain, signing and pavement markings, intersection details, traffic signal, landscaping, etc. Construction centerlines and stationing shall be shown overlaid on the roadway footprint. All roadways shall be identified by name.

Each quarter-section containing proposed construction is to be listed by Township, Range, Section, and Quarter-Section under the heading: Locations For As-Built Indexing.

#### 4.3.7 GENERAL NOTES SHEET

The General Notes Sheet shall contain the project disturbance area (acres), to assist in determining if the construction activities will require coverage under the Arizona Construction General Permit (CGP), issued by ADEQ. Construction projects in urbanized unincorporated areas (UUA) of Maricopa County are regulated by Maricopa County Environmental Services Department (MCESD) Stormwater Quality program. The General Notes Sheet shall contain the project disturbance area (acres) within the UUA. The UUA can be identified in the Road Information Tool (RIT), <https://gis.maricopa.gov/RoadInformationPublic/>, by turning on the Urbanized Areas (Census) layer and the Municipal Annexation layer. The UUA are the cross-hatched areas outside the Municipal Annexation boundaries. Consultants can identify the UUA by following the instructions on this site <https://www.maricopa.gov/4852/Do-I-need-a-Stormwater-Permit>. **Disturbance** is defined by ADEQ under Construction Activity as – **earth-disturbing activities such as, clearing, grading, excavating, stockpiling of fill material and other similar activities.**

The General Notes Sheet shall include the standard abbreviations and symbols provided by MCDOT standard CADD sheets, and shall be used throughout the project sheets where appropriate. New abbreviations and symbols must be added to the General Notes Sheet if used on project sheets, and not available among the standard MCDOT or MAG abbreviations.

General Notes 1. Shall be updated with the appropriate year's edition. Additional General Notes can be added, but General Notes 2 – 10 shall not be modified.

The length of the project shall include the limits of all work within the plan set, excluding utility relocation work that is not a part of the contract.

Design data shall be provided on the primary project road and major cross roads that will have a traffic signal or significant improvement.

The Index of sheets may also include a letter preface to the sheet number to easily identify the type of sheet in large plan sets.

### 4.3.8 QUANTITY SUMMARY SHEET

The quantity summary sheets are to be a single comprehensive tabulation of all construction items defined in the Construction Drawings. The quantity for each item shall be tabulated by sheet number and a grand total for each item shall be indicated. The pay items are to be arranged in ascending numerical order corresponding to the specification sections of the MAG Uniform Standard Specifications for Public Works Construction and the MCDOT Supplement to the MAG Uniform Standard Specifications. Current standard pay item numbers and descriptions are available on the MCDOT website, <https://www.maricopa.gov/DocumentCenter/View/63773/Bid-Item-Master-List>.

Pay items not shown on plans but defined in the specifications, such as Community Relations Support or Mobilization/demobilization, are to be included on the bidding or fee schedule and cost estimate, but not on the quantity summary sheet.

For technical specialty areas that produce a subset of plans (such as bridge plans, signing plans, pavement marking plans, etc.) and the specialty plans customarily include a summary sheet, the specialty summary sheet number is to be referenced on the Quantity Summary Sheet.

### 4.3.9 TYPICAL SECTIONS

A typical roadway section is the standard roadway configuration desired between intersections; it shows standard geometrics that remain constant for hundreds of feet. Deviations from the Typical Section are defined by transition geometrics on paving plan sheets. Transitions geometrics between existing conditions and the typical roadway section are shown on paving plan sheets, they are not included as modifications of the Typical Section. Likewise, changes that occur at intersections are shown on paving plan sheets and not included as Typical Section modifications. Additional Typical Sections are created when the roadway configuration changes and remain constant for hundreds of feet such as a change in pavement width, the addition or deletion of a raised median, or the addition, deletion, or change in width of a sidewalk.

Typical Sections are to show existing and proposed longitudinal elements that may impact construction operations, this includes paralleling channels, canals, storm drain mains, underground utilities, and utility poles.

Typical roadway sections shall be drawn to scale but may be labeled as NTS (not to scale). A vertical to horizontal scale exaggeration or blow-up details may be used as needed for clarity. Typical sections shall show the entire width of existing and new right-of-way. The existing and new right-of-way shall be dimensioned and the distances to the construction centerline shall be

shown. Adjacent easements shall be shown and dimensioned when impacted by construction. Pavement lane widths and slopes shall be identified. Unpaved shoulders shall be labeled as shoulder and their width and slope shall be identified. Embankment and cut slope parameters shall be identified. Variable distances and slopes shall have the maximum and minimum values of the range shown. The stabilization requirements for disturbed areas shall be shown on typical sections. Pavement structural sections shall be identified on typical sections. Variable conditions shall be drawn below the Typical Section without needing to draw a new Typical Section. These variable conditions shall line up with the Typical Section above.

#### **4.3.10 GEOMETRIC CONTROL**

Plan sets shall include geometric control that defines the location and stationing for all proposed construction centerlines and construction control lines based on existing section and quarter section corners, property monuments, and right-of-way monuments. Construction centerlines shall be located by distance and bearings from existing section and quarter section corners or other controlling monuments. Geometric control data shall include the description of found and accepted section and quarter section corners and other found or set monuments. Plans are to show coordinate system metadata and project benchmarks, construction centerline stationing, right-of-way, and identify by name all intersecting streets. Show and label jurisdictional boundaries that are adjacent to the project. When the geometric control information is not complex and the information is shown on the paving plans, a separate geometric sheet will not be required.

#### **4.3.11 PAVING PLAN AND PROFILE SHEETS**

Scale shall be 1" = 20' horizontally, and 1" = 2' vertically. When approved by MCDOT Engineering Division, rural areas may use 1" = 40' horizontally, and 1" = 4' vertically.

When combined plan profile sheets are not used, the profile sheet shall be for the same locations/stations as the plan sheet and immediately follow the plan sheet.

All existing conditions and all new construction shall be shown on the paving plan sheets. All existing and new culverts and buried utilities that cross a profile line shall be shown and labeled in the profile. Existing and new physical survey control shall be shown, including survey monuments per MAG Det. 120. Identify the size and elevation of all existing and new culverts and utilities shown on the profiles, if known. This includes all new pipelines, traffic installations, and other work that may be detailed on other sheets. For items detailed on other plan sheets include a plan note that identifies the sheet number where the detailed information is found.

Projects with curb and gutter or single curb shall show top of curb (TC) and gutter (G) or top of curb (TC) and pavement (P) profiles for all curb lines. Existing ground profiles shall be a superimposed dash line at the same or specified offset as the curb profile. Profiles shall be continuous through all intersections showing pavement profile or valley gutter flow line grades between the curb returns and showing the beginning and ending elevations for all curb returns. The centerline station and elevation of all intersecting roads shall be shown on the centerline profile. For projects with median curbs, provide profiles and define the crown line location and grades through intersections.

Dimensions from the construction centerline to face of curb (F/C) define the roadway width. The distance between the F/C and back of curb (B/C) is seven (7) inches for MAG Detail 220 Curb and Gutter Types A, B, C, D, and E, six (6) inches for MAG Detail 222 Single Curb Type A, or as shown on the curb detail.

Identify on plans the transition locations between standard gutter pan slopes and depressed gutter pan slopes. Identify on the profile the station, point description and elevation for all vertical and horizontal PC, PRC, PCC, PT, angle points, the beginning and ending points of transitions, and sheet match locations. Profiles shall show the existing grade beyond each match point location. The centerline station of all catch basins, scuppers, and driveways shall be identified on the curb profile; the top of curb line does not need to be shown as depressed at driveways or curb ramps.

Vertical curve profiles shall identify the station and elevation of the point of vertical curvature (PVC), point of vertical intersection (PVI), point of vertical tangency (PVT), and for curves containing a slope of zero the high point (HI PT) or low point (LO PT). Vertical curves shall also identify the curve length, beginning and ending tangent grades, midpoint correction (Corr), K value, and the sight distance for crest vertical curves and headlight sight distance for sag curves.

Intersection improvement plans that only have curb returns without adjoining curb and gutter may use spot elevations without profiles. The plan is to identify top of curb (TC) and gutter (G) elevations for the midpoint and each end of curb returns together with flow line direction arrows. For projects with median curbs define the TC and pavement (P) elevations for the median and show the crown line location and elevation control points through the intersection between the median curb lines.

The access route for conducting bridge, culvert, or drainage basin inspection and maintenance activities shall be shown on plans when a direct access route from the roadway is not clearly identifiable. The access route shall be located within right-of-way or an appropriate easement.

#### **4.3.12 STORM DRAIN PROFILE SHEETS**

All culvert and storm drain installations shall have pipe profile drawings. The pipe profiles shall be along the pipe centerline and show the existing and finished surface grades, existing and proposed utilities that cross the alignment, and the wall thickness of pipes and structures. The wall thickness shown for pipes shall be the maximum outside pipe diameter that may occur (such as the outside bell diameter at bell and spigot joints) for all pipe types allowed by the construction documents. The location of the construction center line, existing and new right-of-way and/or easement lines shall be included in the pipe profiles.

Profiles shall extend at least ten feet beyond the end of any structure, inlet, outlet, and special inlet and outlet grading or scour protection. The depth of scour protection, such as riprap shall be shown on the profile.

Culverts that are designed with the invert below the existing streambed flow line shall show and label the designed silting level on the profile drawing.

Storm drain profiles shall show the hydraulic grade line with a note that defines the design storm frequency used to determine the hydraulic grade line.

Connector pipe profiles shall extend at least 10' beyond the items being connected (catch basin, inlet structure, or mainline storm drain). Scale shall be 1" = 5' or as approved by MCDOT. The scale in the vertical and horizontal directions shall be identical.

#### **4.3.13 SPECIAL DETAILS AND OTHER AUXILIARY SHEETS**

Scale as approved by MCDOT. Standard details other than MAG, ADOT, or MCDOT referenced by the construction plans shall be reproduced in the construction documents, either on plan sheets or within an appendix to the special provisions.

#### **4.3.14 SIGNING, PAVEMENT MARKINGS, AND SIGNAL SHEETS**

Signing and pavement markings plan sheets shall be prepared at a scale of 1" = 40'. Signal sheets shall be prepared at a scale of 1" = 20'.

#### **4.3.15 REFERENCE DRAWINGS**

Reference drawings for contractor use and information from utility companies, irrigation districts, or other agencies shall be located at the end of the project plan set. Example: when work to be performed by SALT RIVER PROJECT (SRP) will impact the proposed construction, SRP reference drawings shall be located at the end of the construction plan set.

#### **4.3.16 MASS DIAGRAM**

For MCDOT TIP projects involving earthwork, a project mass diagram shall be provided. Mass diagrams shall identify all assumptions used in generating the mass diagram including ground compaction, shrink/swell factors, and assumptions related to existing pavements. The ground compaction and shrink/swell factors used shall match the recommended values contained in the geotechnical report. The project mass diagram stationing shall match the stationing of the project's primary roadway. Mass diagrams are to include all project earthwork: roadway excavation, fill construction, grading on side roads, channel excavation, and earthwork resulting from construction of retention basins, berms and levees. The mass diagram is to identify the project as a borrow or waste project.

The mass diagram sheet or sheets shall accompany but not be incorporated into project construction documents but shall be information made available to contractors along with cross section sheets.

#### **4.3.17 CROSS SECTION SHEETS**

Final cross sections shall provide a true representation of the project earthwork requirements. Cross sections shall be situated at appropriate locations to provide accurate earthwork calculations. Cross sections shall show the existing grade, the new grade with grade break elevations offsets and slope rates labeled, calculated areas of cut and fill, location of the construction control line, existing and new right-of-way, and easements. Cross sections shall begin at the beginning of the project and extend to the end of the project at regular intervals not to exceed 50', in addition to all intermediate defined horizontal and vertical deflection points along the construction centerline (PC, PT, PRC, PCC, PVC, PVT, High point and Low point). Supplemental sections shall be

included at beginning and end points of transitions and at all locations where abrupt section changes occur.

The cross-sections shall extend through the full width of the existing and new right of way and associated new easements. The full pavement section, including subgrade excavation and treatment locations, shall be shown on the cross-sections. The Design Engineer shall also show locations of existing and new underground utilities both within the roadway prism, drainage ditches, and other locations where a utility conflict may occur.

Cross section sheets shall be submitted both electronically in pdf format and as full size hard copy drawings. Scale shall be 1" = 10' horizontally and 1" = 5' vertically or as approved by MCDOT.

Example cross-section sheets are provided with the MCDOT CADD Standards and the MCDOT Earthwork Guidelines at:

MCDOT CADD Standards:

<https://www.maricopa.gov/3580/CADD-Standards>

MCDOT Earthwork Guidelines:

<https://www.maricopa.gov/DocumentCenter/View/69452/Earthwork-Guidelines-PDF>

Cross section sheets shall accompany but not be incorporated into project construction plans unless otherwise directed.

## **4.4 SPECIAL PROVISIONS AND ENGINEER'S ESTIMATE**

### **Originator: Engineering Division**

#### **4.4.1 CONSTRUCTION SPECIFICATIONS**

Construction within unincorporated Maricopa County right-of-way shall be based on the Uniform Standard Specifications for Public Works Construction sponsored and distributed by the Maricopa Association of Governments (MAG) as modified by the most current MCDOT Supplement to the MAG Uniform Standard Specification and Details for Public Works Construction. The edition and revision of the MAG Uniform Standard Specifications shall be as indicated in the current MCDOT Supplement to the MAG Uniform Standard Specification and Details for Public Works Construction. When construction items are to use a specification from another agency or other source, the specification shall be copied onto the project plans or incorporated into the project's special provisions.

The Design Engineer shall prepare Special Provisions for construction items not contained in or adequately covered by the MAG Uniform Standard Specifications as modified by the MCDOT Supplement to the MAG Uniform Standard Specifications. Special provisions shall be provided as necessary to ensure that each construction item is clearly defined and all material and construction requirements are identified. Special Provisions shall be written and arranged in the same format as the MAG Uniform Standard Specifications. Each page of project special provisions shall be numbered and the project identified (usually located in a header or footer). The Design Engineer shall prepare and submit sealed Special Provisions. Special provisions shall be included with proposed construction documents submitted for review.

For MCDOT TIP projects, the Design Engineer shall provide MCDOT with sealed and signed original Special Provisions along with an electronic copy. The submitted electronic copy shall be in a format acceptable to MCDOT. The Design Engineer shall prepare and submit sealed addenda as may be required to clarify or correct the Construction Contract Documents (Construction Plans, Special Provisions and the Bidding or Fee Schedule).

#### **4.4.2 ENGINEER'S ESTIMATE**

The Design Engineer shall provide MCDOT with a sealed and signed Engineer's Estimate of Construction Cost. The estimate shall contain a comprehensive itemized listing of individual project components with quantities, estimated unit costs and extended total costs identified for each item.

For MCDOT contracted projects, cost estimates shall be formatted as a fee schedule with MCDOT designated pay item numbers and descriptions. When MCDOT provides information on past bid results, it is the Design Engineer's responsibility to evaluate the appropriateness of the information prior to using the information in the Engineer's Estimate.

## **4.5 SURVEY AND DATA ACQUISITION**

### **Originator: Engineering Division**

#### **4.5.1 COORDINATE SYSTEM - DATUMS**

##### **A. LINEAR UNITS**

International Feet (ift) where 1 foot = 0.3048 meters exact.

##### **B. HORIZONTAL DATUM**

The project horizontal datum shall be the North American Datum of 1983 - 1992 epoch NAD83 (1992).

##### **C. VERTICAL DATUM**

North American Vertical Datum of 1988 (NAVD 88) as measured using NAD83 (1992) ellipsoid height and the latest NGS Geoid model.

Establishment of vertical control is covered in section 4.5.2.

##### **D. MAP PROJECTION & MODIFICATIONS**

###### **1. Projects less than 5 miles in length:**

The base map projection shall be a modification of state plane coordinates (SPC), as defined by the National Geodetic Survey (NGS) National Ocean Survey (NOS) 5, Arizona, Central Zone. The modification shall be as follows:

First - Scaling the SPCs to ground from zero (0) northing and zero (0) easting.

Second - Translating the coordinates by -550,000 ift in the northing component. This is done in order to differentiate from unmodified state plane coordinates.

The scale factor used shall be called the Combination Grid Factor (CGF) and is defined as follows:

The CGF is the product of two scale factors, scale (k) and the ellipsoid factor. The scale factor, k, is defined from the ellipse to the grid and shall be derived from the center of the project. The mean ellipsoid height of the project shall be used to solve for the ellipsoid factor of the project. The product of these two scales (k multiplied by the ellipsoid factor) shall be termed the CGF and shall give the total scale to move from the SPC grid to the ground (surface of the earth in the project area) system.

The result shall be a coordinate system at ground. One should be able to obtain NAD83 (1992 epoch) Arizona, central, state plane coordinates from the project ground coordinates by first translating all the points by +550,000 ift north and then scaling (using the reciprocal of the combination grid factor for the project) from the coordinate 0 north,0 east.

*The CGF and any datum transformations used shall be clearly indicated on the Geometric sheet of the design plans. The statement outlining the method of transformation from Ground coordinates to Grid coordinates shall adhere to the following format:*

\*\*\*\*\* Example Metadata Statement \*\*\*\*\*

**COORDINATE SYSTEM METADATA**

**Linear Units:** International Feet  
**Ground Scale Factor:** 0.999848182252  
**Horizontal Coordinate System/Datum:** North American Datum of 1983(NAD83) [1992 epoch]

**Projection:** This project is in a GROUND coordinate system however it is based on the Arizona Coordinate System, 1983 Central Zone, otherwise known as the Arizona State Plane Central Zone (ASPCZ) or "Grid."

**In order to obtain ASPCZ coordinates;**

- a. Translate the northing value by adding 550,000 ift to all northings (the Y component of the coordinates).
- b. Scale (multiply) both the northings (Y component) and eastings (X component) value by the scale factor shown above.

**For Example:**

Given the Ground Coordinates for A365:  
Northing(Y): 340986.192 ift, Easting(X):774061.733 ift and a scale factor of 0.99983908:  
First add the +550,000.00 to the northing to obtain 890986.192 ift.  
Second multiply the new Northing(Y) 890986.192 ift by 0.99983908.  
Third multiply the Easting(X) 774061.733 ift by 0.99983908.  
Result: ASPCZ ("Grid") Coordinates:  
Northing (Y) 890842.815 ift, Easting (X) 773937.171 ift.

All coordinates were derived directly or indirectly from NGS B order stations or better. This includes NGS Continuously Operating Reference Stations (CORS) adjusted back to the 1992 epoch.

Distances displayed are horizontal and are not slope.

**Vertical Datum:**

**Vertical Datum:** NAVD88 (North American Vertical Datum of 1988)  
**Geodetic Datum:** NAD83 adjustment 1992  
**Geoid:** Geoid 2012A (or latest)

\*\*\*\*\*

- 2. Projects greater than 5 miles:  
Contact MCDOT Survey Section for projection parameters.

## 4.5.2 CONTROL POINTS AND BENCH MARKS

### A. DEFINITIONS

Primary Control: Control points that are used to establish Secondary Control. Only MCDOT approved Primary Control points shall be used. Approved Primary Control can be found on the MCDOT Survey website under Land Survey Control Point (map):

<https://gis.maricopa.gov/SurveyPoints/>

Secondary Control: Control points that are established on the project site used for horizontal and vertical control.

Project Bench Mark(s): Can refer to a Secondary Control point or a monument used for vertical control only. The Project Bench Mark shall be within the project limits.

### B. MONUMENTATION

Regardless the size of the project there shall be a minimum of three Secondary Control points set on the project. For projects over 1500 feet, a Secondary Control point/Bench Mark shall be set every 500 feet along the project corridor. In all cases, the Secondary Control points shall be set in such a location as to avoid destruction by future construction. The physical monument shall not be shorter than 16” in length and at least a 5/8 inch rebar. Other suitable monuments may be a chiseled cross or nail in a structure believed not to be disturbed during the construction. An aluminum or brass cap will be permanently affixed to the rebar and stamped with the project number, control point name, year and LS number. These will serve as both horizontal and vertical control for the project.

### C. OBSERVATIONS

#### 1. Horizontal

All control points shall be directly geodetically tied to or surveyed from a MCDOT approved Primary Control point. A Global Navigation Satellite System (GNSS) solution shall be used. Coordinates shall be derived by a mean of a minimum of at least three (3), 90 second observations, with at least one observation taken with a 4 hour separation of time from the other two observations.

#### 2. Vertical

One of the Secondary Control points set near the center of the project shall be chosen to hold the GNSS derived elevation fixed using the aforementioned vertical datum parameters. A closed level loop shall be run through all the remaining Secondary Control points set. The maximum permissible closure shall not exceed the National Geodetic Surveys, Vertical Control Network Standards of Third Order Classification as published by the Federal Geodetic Control Committee under the Standards and Specifications for Geodetic Control Networks. The results of the closed bench circuit shall be adjusted using acceptable surveying methods and the final elevations published on the design plan set. All field notes shall be submitted to MCDOT in standard field book format.

The adjusted *leveled* elevations shall be assigned to each Secondary Control point and be reported in the coordinate table on the Geometric sheet of the design plans.

### 4.5.3 DATA COLLECTION

#### A. OBSERVATIONS

##### 1. Monuments

- a. Found Monuments Not in the MCDOT Point Database:
  - i. GPS: Survey at least 2 times with 90 epochs each. The pole shall be turning 180 degrees from the initial observations to minimize bubble error.
  - ii. Conventional: Survey at least 2 times.
- b. Found Monuments In the MCDOT Point Database: Confirm the description is the same that is in the point database if not survey as a newly found monument.
  - i. GPS: Survey with a 3 epoch observations. If the position matches within 0.10 horizontally and 0.15 vertically, accepted. If outside the tolerance, survey as a new monument.
  - ii. Conventional: Survey at least 2 times.

##### 2. Topography (Topo)

- a. GPS: Survey with a 3 epoch observation
- b. Conventional: Survey with 1 forward face observations.

#### B. SURVEY CODES

The current approved MCDOT Survey Code list shall be used for all for control points and topographic features surveyed.

#### C. POINT RANGE

The current MCDOT Survey Point Range Format shall be used.

#### D. PHOTOGRAPHS

All monuments shall be photographed with a vicinity image and a close up of each monument. If the monument is not easily identifiable in the vicinity photo, there shall be a rod or lath indicating its position. Each photo shall be placed in a folder labeled with the individual point number. (For example, if a monument was surveyed as point 1000 and two photos were obtained then a folder called "1000" shall be created with both photos placed in it.

### 4.5.4 PUBLIC LAND CORNERS, PROPERTY, AND RIGHT-OF-WAY MONUMENTS

- A. All controlling United States Public Land Survey System (USPLSS) monuments set during the original government survey(s) prior to disposal\patent of the public lands, and shown on the official plat(s) of the GLO, BLM, or other authoritative federal agency, including but not limited to section corners, 1\4 (quarter), 1\16, 1\64, etc. corners, lot corners, witness corners, reference monuments, angle points, closing corners and amended monuments, affecting the project, shall be observed with two 90 second GNSS observations with independent initializations.

Any USPLSS corners that are lost or obliterated shall be reestablished per, Restoration of Lost or Obliterated Corners and Subdivision of Sections by the U.S. Department of the Interior, Bureau of Land Management, the current Minimum Standards for Arizona Land Boundary Surveys by Arizona State Board of Technical Registration and Maricopa Association of Governments (MAG).

The position of each monument surveyed shall be reported in the coordinate table on the Geometric sheet in the design plans. This shall include controlling USPLSS monuments set or found for the project, and all supporting USPLSS monuments used to reestablish lost corners that affect the project.

- B. If the contract stipulates that the Right-of-way or parcel lines shall be determined, the position of each monument surveyed shall be reported in the coordinate table on the Geometric sheet in the design plans. A Results of Survey drawing may also be required to be recorded pursuant to Arizona Revised Statutes (ARS) and/or Arizona State Board of Technical Registration (AZ BTR) statute\rules.

#### **4.5.5 TOPOGRAPHICAL FEATURES (FOR BASE MAP GENERATION)**

- A. All topographic features affecting the project shall be surveyed. These include, but not limited to roadways, bridges, curbs, gutters, sidewalks, barriers, fences, gates, irrigation/storm drainages, pipes, railroads, pavement markings, trees (type and size), vegetation and all utility (water, gas, electric, storm, sanitation, traffic, blue stake markings, etc.) features, etc.
- B. Sufficient elevations on topographic features and spot elevations (along the project road and crossroads alignments) shall be obtained to create an accurate Digital Terrain Model (DTM) for design purposes.
- C. Topographic features and spot elevations shall be collected in cross section format. Cross sections shall be taken at every 100 feet along tangents, 50 feet along curves, with additional sections taken at grade breaks. Horizontal and vertical limits shall extend 25 feet beyond proposed right-of-way left and right, with right-of-way elevations given at average natural ground. Cross sections shall extend 300 feet beyond the beginning and end of the project.
- D. Existing edges of pavements, major drives, traffic signals, traffic striping, and traffic signs shall be surveyed to 500 feet beyond each end of the project.
- E. The elevation of all ditch flow lines, tops of banks, tops of linings, high water marks, culverts, pipe inverts, manhole rims and inverts , tops of headwalls, building finished floor elevations, water valves at operating nut and valve box cover, irrigation bench mark monuments, and similar features shall be obtained and clearly noted.
- F. Field measurements and notations for irrigation and drainage facilities shall include: feature description, type, structure sizes, shapes, material, type, direction and invert elevations of all pipes and culverts.
- G. Field measurements and notations for fences, walls, and gates shall include: type and sizes, material, and direction.
- H. Features and/or elevations that could affect or be affected by the design shall be recorded and shown. Porches, signs, overhangs, clearances, electrified signs, and motorized gates shall be noted. Significant dimensions of the objects must be recorded.

- I. Major drainage features shall require additional cross sections, both upstream and downstream of the project 300 feet left and right of centerline.
- J. When applicable, floor elevations shall be shown on the plans for houses and buildings within a minimum of 125 feet from the centerline.
- K. All marked Blue Stake lines and features shall be part of the topographic information obtained.
- L. The existence and direction of overhead lines is to be noted. Any potential conflict with overhead lines (electric or communication cables) requires an observation at the sag (or low) point.
- M. Elevations beyond the proposed right-of-way line must be recorded in the field notes for driveways and irrigation facilities that may require alterations beyond the right-of-way. Elevations shall also be obtained and recorded in the field notes for all parking areas on adjacent property to ensure that the property will properly drain in conjunction with new roadway grades.

#### **4.5.6 DRAWING GENERATION (SURVEY MAPS)**

##### **A. SURVEY MAPPING**

Survey maps shall be produced in accordance with the MCDOT CADD Standards.

At a minimum two (2) MicroStation drawings shall be produced: a coordinate geometry drawing and a topographic drawing.

- 1. The coordinate geometry “BC” (aka COGO) drawing shall contain all pertinent monuments found or set, along with all Public Land breakdowns, parcel and centerline representations. Example formats are available on the MCDOT web site under CADD standards in the dgn zip file. The drawing shall contain but is not limited to the following:
  - a. Labeling of the streets, monuments (number, description, representation (i.e. section corner, etc)), bearing and distances of all key lines.
  - b. Although primarily the responsibility of the Design Engineer, if a construction centerline is requested as part of the surveying firm’s scope of services, appropriate ties (bearing and distance) shall be annotated to found existing monuments, preferably public land corners and/or street intersection monuments that will not be affected by the new road design or construction.
  - c. Metadata Statements (see example in 4.5.1 D)
  - d. Coordinate List of all found, set and calculated points. Identify which monuments are to be used for horizontal control and vertical control (construction benchmarks).
  - e. Records List - All recorded and unrecorded documents used to determine parcel breakdown and centerline positioning.
  - f. When monuments are not found or accepted, provide a detailed explanation of how the new position was determined and identify the documents used in the determination.
- 2. The topographic drawing “BE” shall contain the topography of the existing terrain and all pertinent features.

**B. HORIZONTAL ACCURACY**

Survey accuracies shall meet or exceed the current American Land Title Association (ALTA) Accuracy Standards, (0.07 ft + 50 ppm) and shall never be reported at anything less than the 95% confidence interval.

**C. VERTICAL ACCURACY**

Not more than 10 percent of the contour elevations tested shall have an error more than one-half the contour interval. In checking elevations taken from the map, the apparent vertical error may be decreased by assuming a horizontal displacement within the permissible horizontal error for a map of that scale.

The Contour Interval shall be no greater than 1/2 foot unless otherwise indicated in the contract.

**4.5.7 PHOTOGRAPHS**

**A. MAPPING**

In the case of complex structures that are difficult to represent or convey in the topographic drawing, photos shall be obtained and labeled to aid in the design process.

**B. MONUMENTS**

All monuments set (excluding panel points) or found shall be photographed. A minimum of three (3) photos shall be taken;

1. Close up Photo. The monument shall be in focus and capture any relevant stamping or identification.
2. General photo. A photo of the monument and the surrounding area.
3. Vicinity Photo. A photo of the monument with horizon on the shot. If available a street sign or other identifiable feature should be included in the photo. Either a lath, survey rod or something equivalent should be in the photo if it is not apparent where the monument lies in the photo.

Each monument surveyed shall have a separate folder created with its monument point number and the corresponding photos placed in said folder.

**4.5.8 DELIVERABLES**

Upon completion of the survey mapping, the following shall be submitted to the MCDOT Survey Manager:

**A. NON DIGITAL MEDIA**

1. Field book(s): Clear, complete, fully indexed field notes with all abbreviations explained, an alignment/geometrics layout clearly designating point numbers and descriptions, bench mark level notes, any necessary details drawn for clarification and a listing of all digital files submitted with full descriptions. The cover shall be signed and sealed by an Arizona Registered Land Surveyor.
2. Any unrecorded surveys or as-built plans NOT obtained from MCDOT.

**B. DIGITAL MEDIA**

Directories and subdirectories shall be created so as to produce an organized structure that is easily followed to obtain the copied files. The following items shall be copied into the appropriate directories of a CD with the MCDOT project name, work order number, land surveyors stamp and signature on the label;

1. Data Collection Files

All files associated with the data collection, including but not limited to:

- a. GNSS project(s) (i.e. Trimble Geomatics Office, Trimble Business Office, etc.)
- b. Level runs.

2. CADD

All files associated with generating the survey maps, including but not limited to:

- a. Raw Data – The appropriate raw data for the software utilized.
- b. Coordinates – Comma delimited ASCII format listing point number, northing, easting, elevation, descriptor codes, and notes.
- c. Digital Terrain Model – Bentley InRoads .dtm format
- d. Points File – Bentley InRoads .alg format.
- e. Drawings/Exhibits – MicroStation .dgn format.
- f. Field book – Bentley .fwd format

3. Monument Coordinate List

Comma delimited file: Point Number, Latitude, Longitude, Ellipsoid Height, Northing, Easting, Elevation, Date Surveyed and Monument Description.

4. Photographs

All photos taken of the project.

5. Miscellaneous

Any and all files that were used in conjunction with generating the survey maps.

## **4.6 GEOTECHNICAL DESIGN**

### **Originator: Construction and Materials Division**

#### **4.6.1 GENERAL**

A geotechnical investigation report shall be prepared by a civil engineer licensed by the State of Arizona who is experienced and knowledgeable in soil engineering and pavement design and who derives his livelihood in this specialized field of engineering. This specialist is referred to in the geotechnical design portion of this manual as the “Geotechnical Engineer”.

MCDOT recognizes that environmental, geologic, and geotechnical conditions can vary from those encountered at the times and locations where data are obtained. MCDOT also recognizes that, despite due professional care, limitations on available data may cause some uncertainty in the interpretation of these conditions.

Upon review of the data available and information furnished, the Geotechnical Engineer for County contracted work shall consult with MCDOT before beginning field explorations and tests for the project.

#### **4.6.2 FIELD EXPLORATIONS AND TESTS**

The Geotechnical Engineer shall:

- A. Perform geologic examinations and subsurface explorations of the project site. Field exploration shall include a personal field inspection to observe existing surface features and condition of nearby structures.
- B. Sub-surface exploration methods used (i.e. Backhoe pits, auger drilling, or rock coring) shall be determined by the Geotechnical Engineer and shall be appropriate for the specific needs of the project. When structures are involved, typical fieldwork shall include standard penetration testing or open-end drive sampling, Shelby tube sampling or tube sampling by other method appropriate for the soils involved at 5-foot intervals in the borings.
- C. Where significant structures are involved, the field exploration shall include inspection of any available (Geological, Agronomy, Aerial, or Topographic) maps of the area, water-well logs and hydrologic data.
- D. All open test holes must be adequately covered during periods of inactivity and all test holes must be backfilled upon completion of field explorations;
- E. All samples shall be preserved and made available for inspection by MCDOT for a minimum period of six months after submittal of the final report. However, in no case shall the time and manner of disposal specified by testing procedures be violated;
- F. Perform the tests necessary for geotechnical engineering analysis for the project.
- G. Qualified, experienced personnel shall perform all tests in accordance with applicable standards. Tests shall be conducted by a laboratory accredited by the AASHTO Materials Reference Laboratory (AMRL) in the area of “Soils”.

### 4.6.3 ANALYSIS AND REPORT

The Geotechnical Engineer shall analyze the results of field explorations and laboratory tests and prepare a written report on the findings.

The report shall be suitable for reproduction and shall include:

- A. Project description, to include: purpose of report, project limits and location, type of proposed improvements, construction limits, general existing conditions, i.e., topography, vegetation, drainage, areas of potential environmental concerns, etc.;
- B. A narrative description of the general geology of the project area. This would typically include a description of the source and nature of deposits, depth/ thickness and composition of strata making up the subgrade soil profile, estimated location of bedrock, quality of bedrock if it is within five feet of subgrade or foundations, location and variation in groundwater table, if it is within the zone of design interest, and areas of potential problems (springs, unstable slopes, expansive soils, corrosive soils, contaminated soils, earth fissure, subsidence, etc);
- C. For projects where substantial cuts and fills (greater than 2 feet) are anticipated, a site topographic map shall be prepared showing proposed cuts and fills, anticipated grades, locations of drainage and irrigation facilities, i.e. storm drains, drain fields, dry wells, detention/retention ponds, channels, etc.
- D. Logs of test borings, a site plan showing their locations (vertical and horizontal) and a description of procedures and equipment used in the boring program.
- E. Results of laboratory tests and a description of test methods;
- F. A discussion of the foundation system or alternative systems recommended for consideration for the project;
- G. Recommended foundation bearing pressures or capacities, foundation depths and geometrics, and criteria for design for the resistance of lateral loads;
- H. Earth pressures and other criteria for the design of retaining walls and other earth retaining structures;
- I. Estimated foundation settlements;
- J. Recommended cut and fill slopes;
- K. Recommended values for earthwork shrink/swell and ground compaction factors;
- L. Guide specifications for recommended construction methods or materials that differ from the Maricopa Association of Governments (MAG) Uniform Standard Specifications and Details for Public Works Construction as supplemented by MCDOT;
- M. Special treatment recommended for any expansive soils, “collapsing” soils, man-made fills or other moisture-sensitive materials that may be present beneath the site.
- N. Pavement structure sections.
- O. Professional interpretations of the foregoing as appropriate.
- P. A summary of the findings with appropriate exhibits to indicate the geotechnical considerations involved and setting forth recommendations with project criteria as specified elsewhere.

#### **4.6.4 SOIL PARAMETERS FOR TRENCH SHORING DESIGN**

Soil parameters for trench shoring designs shall be provided in the geotechnical report.

#### **4.6.5 PAVEMENT DESIGN**

Roadway pavements shall be asphalt concrete or Portland cement concrete. Pavement design shall comply with all requirements of Chapter 10 Pavement Design Guide.

#### **4.6.6 BORROW MATERIAL**

Define quality requirements for imported fill material for construction of roadway fills. The recommendation is to be expressed in terms of the percent passing the 200 sieve and the plasticity index.

#### **4.6.7 SUBMITTALS**

The geotechnical investigation report shall be included in the construction documents submitted to MCDOT for review.

## **4.7 DRAINAGE DESIGN**

### **Originator: Engineering Division**

#### **4.7.1 GENERAL REQUIREMENTS**

Drainage design shall be in accordance with the *Drainage Policies and Standards for Maricopa County, Arizona* (DPSMC). Hydrology, hydraulics, and erosion control designs shall be consistent with the current Drainage Design Manuals issued by the Flood Control District of Maricopa County (FCDMC). The drainage design shall not have adverse impacts to upstream or downstream areas.

**Right-of-Way Offsite Drainage:** Right-of-way offsite drainage pertains to stormwater runoff originating from upstream tributary areas that enter or have the potential for adversely impacting the road right-of-way. Offsite design discharges shall be based on storm frequencies described in the DPSMC unless MCDOT has provided prior approval for a design using a lesser storm frequency.

**Right-of-Way Onsite Drainage:** Right-of-way onsite drainage addresses storm water runoff from watersheds within the road right-of-way that discharge to storm water control facilities such as storm drains, roadside ditches, culverts, detention basins, retention basins, and spillways. Onsite discharge design shall be determined using the Rational Method. The minimum time of concentration to be used is 5 minutes.

#### **4.7.2 HYDRAULICS**

**Open Channel:** Two-dimensional modeling shall be provided for in distributary flow areas when requested by MCDOT. When open channels are proposed to intercept flows approaching the right-of-way, open channel flow modeling shall be used. Computations for channel design elements, such as bank protection, irregular channel alignments, and for outlet protection shall be provided.

Flood limits, depths, and velocities shall be kept unchanged unless: (1) Drainage improvements are provided to prevent flood damage, (2) Flood limits are contained within the road right-of-way, or (3) Drainage easements are acquired to encompass the increased flooding limits when extending outside the road right-of-way. In no case shall a habitable structure be subjected to increased flood limits due to improvements. Computations and exhibits shall be provided to the extent that pre-developed and post-developed flood limits, depths, and velocities are equal or provide a beneficial improvement.

The potential for erosion or sedimentation occurring in channels shall be considered.

**Cross Drainage:** When cross-drainage structures are located within natural washes or major watercourses, open channel hydraulic modeling is required to evaluate the pre-developed and post-developed floodplain and flow characteristics of the natural wash.

Design drainage crossings and associated channels to convey the appropriate return period storm under the roadway as described in the DPSMC. In addition, the 100-year storm is not allowed to overflow to adjacent drainage basins.

End sections, headwalls, wingwalls, channels, riprap and erosion protection shall be located outside of the clear zone or made traffic safe.

Areas with high erosion potential such as exists at the ends of headwalls, wingwalls, retaining walls, and other similar structures shall include erosion protection measures in the design. Where channels occur adjacent to embankments, erosion protection measures for embankment protection shall be included in the design.

Storm drains and open channels discharging into or adjacent to culvert or bridge structures shall be designed to prevent erosion or damage to the structure. Where possible, storm drain outlets are to be located on the downstream side of the roadway through the outlet wingwalls.

An evaluation of the outlet scour potential shall be made at all culverts. Outlet protection shall be designed in accordance with the FCDMC Hydraulic Manual.

**At-Grade Crossings:** When at-grade crossings are approved, the 100-year flow traversing the road should not exceed 6 inches in depth and the velocity should not exceed 5 feet per second. Unless otherwise approved by MCDOT at-grade low water crossings shall use concrete pavement with cut-off walls.

### 4.7.3 BRIDGES

**Bridge Hydraulic Design:** HEC-RAS shall be used to analyze the hydraulic conditions at bridges. Transitions and friction head losses as well as pier head losses shall be considered.

The bridge waterway opening shall be designed to meet the 100-year design storm frequency with the extreme storm event as the check storm criteria. The extreme event is defined as the flood resulting from a storm having a flow rate in excess of the design flood, but in no case a flood with a recurrence interval exceeding 500 years. The waterway opening shall be sized and situated to:

- Limit backwater;
- Minimize bank erosion and bank protection requirements;
- Discourage progressive sedimentation; and
- Minimize general and local scour.

Backwater computations for a bridge shall be based upon approved methodology. The design conditions which result in the highest value of backwater shall be used for design. Backwater shall be computed with no allowance for scour (i.e. with rigid channel boundaries).

Bridge piers and abutments are to be located to:

- Minimize hindrance to the passage of water and debris;
- Be compatible with the location of piers and abutments of adjacent structures;
- Minimize the depth of local scour; and
- Minimize upstream and downstream bank erosion.

Bridge piers shall be round or have the upstream end rounded. Solid wall piers should only be used where the direction of flow is well controlled and will remain so in the future. Piers are not to be designed specifically to align the flow.

**Freeboard Requirements for Bridges:** Freeboard shall be a minimum of 2' above the 100-year high water elevation, unless otherwise approved by MCDOT.

There are no freeboard requirements for the 500-year event. If practicable, the bridge approaches should be allowed to overtop during storm events exceeding the 100-year event, to protect the bridge from runoff greater than the 100-year event.

The minimum vertical clearance under bridges is five feet. This is for maintenance and inspection purposes.

**Deck Drainage:** Bridge deck drainage shall comply with pavement drainage requirements.

Deck drainage on railroad overpasses shall be conveyed in a piping system from deck drain inlets to a properly designed drainage outfall system. The use of piping systems for other bridges or overpasses may also be required. Particular care must be taken regarding bridge deck drainage at the beginning and end of the bridge deck in order to prevent erosion of the approach roadway embankment.

#### 4.7.4 PAVEMENT DRAINAGE

Design storm frequencies and spread criteria for pavement drainage shall be as described in the DPSMC.

#### 4.7.5 STORM DRAIN DESIGN

The storm drain shall have a minimum full-flow velocity of at least 3.0 feet per second.

Outlet discharge velocities shall be determined and outlet protection and/or energy dissipation provided as needed to prevent adverse downstream conditions.

All storm drain system elements shall be shown on the construction project plan and profile sheets, including but not limited to pipe size, material, invert grades, hydraulic grade line, existing and proposed finished grade along the pipe centerline, and all catch basins, manholes, junction structures, bends, transition structures, connectors, and elevation of all inlets and outlets.

Calculations of head losses through junctions, bends, manholes, and catch basins, using the procedures described in the FCDMC Hydraulic Drainage Design Manual. Junction losses do not need to be considered when the incoming lateral flow is less than 10% of the combined mainline outflow.

Soffits of adjoining pipes in a transition or junction structure shall be form a smooth continuous line without vertical displacement, unless other constraints such as utility conflicts exist and are approved by MCDOT.

Where storm drains discharge into an open channel, the frequency of storm for determining tail water depth in the channel is not necessarily that for which the storm drain is being designed. It shall be based on the comparative size of the tributary areas of the channel and the storm drain.

#### **4.7.6 DRAINAGE REPORT REQUIREMENTS**

I. Title Page. The title page of the Drainage Report shall contain the following:

- A. Project Name
- B. Preparer's Name, Firm, and Date
- C. Professional Engineer's Seal and Signature

II. Introduction. The introduction of the Drainage Report shall include the following:

- A. Identification of street name and location using section references
- B. General description of existing site conditions
  - 1. Topography, ground cover, soils, etc.
  - 2. Existing drainage and irrigation facilities
  - 3. Existing flood hazards (Flood plains, alluvial fans, etc.)
- C. General description of proposed project
- D. A statement indicating that the drainage report has been prepared in accordance with the current versions of the Drainage Policies and Standards for Maricopa County and the Hydrology and Hydraulics Drainage Design Manuals for Maricopa County. The statement shall, for each of the references, identify the version, edition, or revision and its date.

III. Previous Studies

This section shall provide a description of all previous studies readily available and relevant to the proposed project. Include all drainage reports, master plans, flood hazard studies, and discuss their relevance to the project. Provide full reference for all information sources.

IV. Hydrologic and Hydraulic Analysis

- A. Describe method used for runoff computations
- B. Discuss design storm intensities or depths.
- C. Describe method used to determine hydrologic parameters, and include reference to the appendix containing hydrologic computations. Include appropriate geotechnical information if used to support the hydraulic design (i.e. natural channels).
- D. Describe methods used for hydraulic computations. Discuss typical parameters used, and include reference to the appendix containing hydraulic computations. Include appropriate geotechnical information if used to support the hydraulic design (i.e. natural channels).

V. Historic Drainage System. The Drainage Report shall provide sufficient information, including text and maps where possible, to describe the historic drainage system. This information shall include:

- A. Major basins (100 acres or more), including relationship to major drainage facilities, and major basin drainage characteristics (topography, runoff, cover, use, erosion).
- B. Sub-basin and site drainage, including storm flows for each sub-basin affecting the site, existing drainage patterns, channeled or overland flow, points of entrance and discharge, flood hazard areas, and other drainage related features. A map showing off-site basins shall also be included. All items listed in Subsections A and B may be presented on a map or drawing.

- C. Discussion of hydrologic and hydraulic analysis results for existing drainage conditions and facilities, including those items on drawings and maps not discussed elsewhere. Discussion shall include flow rates and paths, drainage facilities, irrigation ditches, impact of site runoff on adjacent properties, and any other relevant information.

VI. Proposed Drainage System. As a minimum, the following information regarding the proposed drainage system shall be provided in the Drainage Report. Maps shall be used to complement and clarify the description where appropriate.

- A. Description of major basins and tributary sub-basins. Refer reader to appropriate figures or drawings.
- B. Results of hydrologic and hydraulic analyses. Include summary tables if needed to facilitate discussion of results. Refer reader to the appropriate appendix, if applicable.
- C. Description of the proposed storm drainage system to manage design storm runoff. Discussion should include management of off-site runoff tributary to the project site, on-site flows, and anticipated phasing of future downstream facilities that comprise the off-site drainage system for the proposed project. Identify any interim facilities that need to be constructed, and the authority under which such facilities will be constructed, until permanent off-site drainage facilities are in place. The intent of the off-site facilities information is to permit the reviewer to determine the impacts of proposed development on off-site facilities and property prior to the construction of permanent off-site local or regional drainage systems. Discuss capacity of system to pass the design storm flows within and through the project.
- D. Discussion of potential for and risk of sediment inflow and debris flow into the proposed drainage facilities.
- E. Discussion of detention/retention requirements. For proposed detention/retention facilities the following information shall be provided:
  - 1. Volume required and provided.
  - 2. Emergency overflows provisions which will not cause a direct impact to neighboring sites
- F. Discussion of compatibility of proposed design with previous studies. Provide justification of deviation from any design constraints recommended or imposed by previous studies or master plans.

VII. Where the proposed development is located within a special flood hazard area or critical flood storage area, sufficient information shall be provided for the following:

- A. Evaluation of the impacts of proposed development on the flood hazard area within the project area and with respect to adjacent properties. If specific analysis was performed for flood hazard area consideration, include description of analysis and pertinent backup data and calculations as applicable.
- B. Description of impact of the floodplain on the proposed storm drainage system(s).
- C. Discussion of compliance with flood Plain use permit, FEMA requirements for Conditional Letter of Map Revision (CLOMR) / Letter of Map Revision (LOMR) submittal, if applicable. Include reference to all CLOMR/LOMR's submitted to FEMA for this project.

VIII. Conclusions. This section shall discuss the impacts of the proposed drainage system improvements, including:

- A. Compliance with all Manual policies and requirements

- B. Requested Manual exemptions
- C. Compliance with State and Federal Regulations
- D. Compliance with local flood plain/flood hazard regulations
- E. Benefits provided by the proposed facilities to off-site systems
- F. Adverse effects to off-site systems and mitigation measures for these effects
- G. Ability to provide emergency all weather access

IX. References. Include references for all sources of information used in report.

X. Drainage Report Appendices. The Drainage Report shall include the following information in the Appendices.

- A. Site Location Map at a scale appropriate to show relation of site to major drainage basins and sub-basins; flood hazard areas and 100-year flood plains, if applicable; and off-site flows through project.
- B. Computations. Hydrologic and hydraulic computations including:
  - 1. Hydrologic and hydraulic parameter determination and source references
  - 2. Off-site and on-site historic runoff
  - 3. Off-site and on-site proposed-development runoff
  - 4. Street capacity calculations identifying depth and velocity for the design storms
  - 5. Inlet and catch basin capacity calculations
  - 6. Open channel calculations with depth, velocity, HGL, and freeboard provided for minor and major design storms
  - 7. Retention volume calculations with required and provide volumes, excess volume provided.
  - 8. Storm drain hydraulic grade line (HGL) calculations for minor and major design storms
  - 9. Design calculations for all hydraulic structures
  - 10. Copies of all equations, tables, figures, charts, etc. used for the analyses (with references)
  - 11. Basin schematic showing connectivity between sub-basins, flow conveyance elements, and other pertinent modeling nodes
  - 12. Capacity analysis of off-site facilities
  - 13. Geotechnical information (as needed to support hydraulic design assumptions)

C. Drawings and Figures. Include Drainage Plan.

**Drainage Plan:** A detailed drainage plan(s) that addresses existing and proposed conditions for the subject site shall be submitted with the Technical Drainage Report. The plan(s) shall be on a 24" x 36" drawing at an appropriate legible scale (a scale of 1" = 50' to 1" = 500' is recommended). The following information shall be shown on this drawing, except that the off-site drainage basin boundaries may be shown at an appropriate legible scale on an exhibit.

- 1. Property lines (existing and proposed) and streets (roads) including right-of-way widths within 100 feet of the property.
- 2. Existing and proposed contour elevations sufficient to analyze drainage patterns extending a minimum of 100 feet outside the project area.

3. Existing drainage facilities and structures, including ditches, storm sewers, channels, street flow directions, and culverts. All pertinent information such as material, size, shape, slope, and location shall also be included.
4. Limits of existing flood plains based on Flood Insurance Rate Maps, if available. Also, existing flood plains based on best available data (existing flood plain studies) should be shown where available.
5. Proposed on-site drainage basin boundaries with appropriate basin labels. Include off-site basin boundary intersections with on-site basin boundaries if not shown elsewhere. Label all design points.
6. Proposed future on-site and off-site flow directions and paths
7. Proposed Street and ditch flow paths and slopes
8. Proposed storm drain including inlets, outlets, manholes labels.
9. Proposed channel alignment with typical cross section. Include major storm flow limits.
10. Proposed culvert labels.
11. Proposed On-site Drainage System outlet(s) to the Off-site Drainage System
12. Proposed Off-site Drainage System from site to Major Drainage System
13. Detention/retention facilities and related structures.
14. Miscellaneous proposed drainage facilities (e.g. hydraulic structures, erosion protection, etc.)
15. Table of minor and major storm peak flows including tributary area at critical design points and Rational Method design data (where used)
16. All Drainage and maintenance easement widths and boundaries
17. Labels of all inlets and manholes to correspond to tabular number system
18. Table of pipe sizes, grades, velocities, peak flows, and HGL
19. Legend for all symbols used on drawing
20. Reference to datum
21. Scale, North Arrow, Title Block, Professional Engineers Signature, Seal, Date

D. Digital Data: A CD containing a PDF copy of the drainage report and digital copies of all electronic calculations, including spreadsheets, and executable copies of all hydraulic and hydrologic models used shall be submitted for review.

#### **4.7.7 ASSORTED DRAINAGE DESIGN REQUIREMENTS**

Safety rail shall be installed on headwalls and wingwalls at all locations where the distance between the top of the headwall or wing wall and the ground is 30 inches or greater. Safety rail should also be installed on headwalls and wingwalls located in areas where pedestrians may be present.

An access route for conducting bridge, culvert, or drainage basin inspection and maintenance activities shall be provided within right-of-way or an appropriate easement. The access route for inspection and maintenance activities shall be shown on plans when a direct access route from the roadway is not clearly identifiable. Access routes shall be at least ten feet wide, the cross slope shall not exceed 10:1 (Horz:Vert), and the longitudinal slope shall not exceed 6:1 (Horz:Vert).

#### 4.7.7.1 Culverts

Culvert pipe design shall follow the Arizona Department of Transportation (ADOT) *Pipe Selection Guidelines and Procedures Manual* and ADOT *Plastic Pipe Selection Guidelines* as amended herein.

Pipe used for culvert and storm drain construction, including specials, joints, and gaskets, shall be according to the following requirements:

- Rubber Gasket Reinforced Concrete Pipe (RGRCP).
- Reinforced Concrete Pipe (RCP).
- High Density Polyethylene (HDPE).
- Polypropylene Pipe (PP).

Pipes placed within the limits of street pavement shall be RCP or RGRCP. The limits of street pavement is defined as within two (2) feet outside of single curb, curb and gutter, attached and detached sidewalk, multi-use pathways, driveways, roadway shoulders (paved and unpaved), valley gutters, etc. This requirement shall also apply to trenches within the traveled way of an unpaved roadway.

HDPE and PP are allowable pipe alternates in locations outside of the limits of street pavement.

MCDOT Transportation Improvement Program (TIP) projects that will be conveyed by annexation or an intergovernmental agreement to a local jurisdiction for future operation and maintenance will be designed and constructed in accordance with the local agency design and specification requirements.

Pipe materials, trenching and backfill, compaction, pavement and surface restoration, and other construction requirements for ADOT, local agencies, irrigation districts, and within railroad right-of-way shall be in accordance with the standards, specifications and permit requirements of the respective agency.

Culvert plans shall include a note that defines the design storm frequency and design peak flow for each installation having a total culvert cross sectional flow area greater than eight square feet (pipe diameter greater than 36”).

The minimum pipe culvert diameter for roadway crossings is 24 inches. The minimum pipe culvert diameter for driveway culverts is 18 inches. Elliptical and arch pipe sizes equivalent to the stated minimum pipe diameters are acceptable alternatives. In areas where sedimentation is a problem the use of arch and horizontal elliptical pipes is subject to MCDOT approval.

The minimum inside height of box culverts shall be 5 feet above the natural streambed elevation. The minimum height of arch culverts shall be 5 feet. In alluvial soils such as found in desert wash areas, the preferred minimum height of box culverts is 6 feet with the invert set 6 inches below the existing streambed flow line. At locations with vertical constraints, the minimum inside height of a box culvert may be 4 feet.

Unless otherwise authorized, the minimum cover over concrete box culverts is 12 inches, and the minimum cover over pipe culverts and arch culverts is 18 inches. The minimum cover is measured from the top outside of pipe to the finished grade. The minimum cover over pipe culverts may be reduced for residential driveways based on pipe strength, vehicle loadings, and proposed backfill and haunching materials.

A structure selection report shall be provided to show the economic advantage of a multiple cell box culvert over a bridge structure when the (opening width exceeds 75 feet) number of cells in the box culvert is larger than 6.

The use of arch culverts shall require specific approval from MCDOT. The term arch culvert as used herein does not apply to pipe arch culverts.

All pipe culverts shall include an end treatment (catch basin, end section, or headwall).

#### **4.7.7.2 Storm Drains**

The pipe material requirements for storm drains within County right-of-way shall be the same as for culverts, with the additional requirements as follows.

The main line pipe profile shall include the hydraulic grade line and a note that identifies the design storm frequency used to determine the hydraulic grade line.

Minimum pipe diameter for storm drains shall be 18-inches. Catch basins and inlets draining paved surfaces may use connector pipes shall be RGRCP with a minimum diameter of 15 inches.

Temporary subgrade drains shall be constructed in roadway catch basins to allow roadway drainage during construction.

#### **4.7.7.3 Valley Gutters**

Valley gutters shall be constructed of Portland cement concrete in accordance with MAG Standard Details. Valley gutters when used shall be located at street intersections; with MCDOT approval they may be allowed on local residential streets between intersections. Valley gutters shall not cross arterial or major collector roads.

## **4.8 BRIDGE DESIGN**

### **Originator: Engineering Division**

MCDOT recognizes the special requirements for bridges. The design and details shall meet the requirements of this Design Manual.

#### **4.8.1 DESIGN PARAMETERS**

New bridges shall be designed using the AASHTO LRFD Bridge Design Specifications, latest edition. ADOT Bridge Design guidelines shall be followed and incorporated into all project documents.

Widening of existing bridges shall use the Design Specifications of the original design with the Live Load increased by 25 percent or the AASHTO LRFD Bridge Design Specifications. The increased loading is to decrease the influence of differential settlement and unaccounted for stresses at the joint between new and old structure.

A structure selection report comparing at least two structural systems shall be used to demonstrate the economic advantage of multiple cell box culverts with greater than six (6) cells and for bridge structures greater than 60' in length. A structure selection report is not required for multiple cell box culverts with six (6) cells or less, or for bridge structures 60' or less in length.

The width and length of the bridge deck and the width and location of sidewalks are subject to approval by MCDOT. Design load, design flood, and other pertinent factors are subject to approval by MCDOT. The profile over the bridge shall be incorporated into the roadway profile. Bridge profile grades shall be no flatter than 0.5%.

#### **4.8.2 UTILITY ACCOMMODATIONS**

The placement of utilities or attachment of utilities to culverts and small bridges is to be avoided. No rigid conduit for gas or product lines will be permitted to be attached to a bridge structure unless it can be demonstrated that there are no reasonable and prudent alternatives. Attachment of a rigid conduit for gas or product line on a structure will generally be limited to major river crossings or on projects involving bridge rehabilitation or replacement where there is an existing utility attachment.

If flexible conduit for gas or other product lines are allowed, the lines shall be placed in sealed sleeves which are vented to the outside of the bridge providing the installation does not adversely affect the structural integrity or safety of the bridge.

When gas or product lines are approved for attachment to a bridge, provision shall be made during design of the bridge to provide for casings, sleeves, access openings and other appurtenances together with special provisions for safety. The utility company will be responsible for all additional costs incurred.

Placement of manholes or points of access within the roadway pavement on or at the ends of bridges shall be avoided.

### 4.8.3 REQUIRED DESIGN DOCUMENTS

The Design Engineer shall perform/provide the following:

- A. Survey to establish topographic mapping; locate significant features, such as existing bridge or other structures; define width and profile of canal or channel; and to establish ties to section corners, benchmarks, etc.
- B. Hydrology and Hydraulic Analysis (not needed for the irrigation canal bridges or grade separations). The report shall include a scour analysis and shall determine the optimum size bridge opening, define the resulting effect on the upstream floodplain during the Design Flood, and determine design parameters for upstream and downstream improvements. The Conditional Letter of Map Revisions (CLOMR) per FEMA requirements shall be included.
- C. Bridge Selection Report to determine the recommended type of bridge structure. At least two types of structures shall be evaluated.
- D. Canal Profile Study to determine canal alterations.
- E. Soil Boring Report (Geotechnical Report) to determine foundation requirements and soil parameters for the bridge foundation design. At least one boring per foundation unit. Depth of borings shall be a minimum 20 feet below the bottom of the foundation structure. Bore hole locations shall be within ten feet (10') of the pier/abutment footprint as indicated in Appendix C of the Materials Preliminary Engineering and Design Manual distributed by the Arizona Department of Transportation.
- F. Structure Design Calculations.
- G. Construction Plans based on using the current MAG construction specifications and details as supplemented by MCDOT.
- H. All standards referenced in the construction documents other than MAG, MCDOT, or ADOT are to be included within the plans or special provisions.
- I. Quantity Calculations and Estimated Costs.
- J. Cross Sections used to calculate earthwork volumes.
- K. Special Provisions.
- L. A bridge load rating report with ratings in both LFR and LRFR.

### 4.8.4 CONSTRUCTION PLANS

Plans shall as a minimum include the following:

- A. Standard Title Sheet with Vicinity Map and Project Location.
- B. General Notes Sheet with Index of Drawings and Approximate Quantities Table.
- C. Location Plan - showing existing topography, hydraulic data, existing and proposed profiles, proposed bridge in plan and profile, existing bridge general details, and geometric controls including bench marks and ties to section corners. Access routes and easements for inspection and maintenance activities shall be identified.
- D. General Plan of Bridge - showing plan and elevation of proposed bridge, and typical section. Depending on the scale and size of the project, a separate sheet may be needed for the typical section.
- E. Soil Boring Log - showing location of borings, top of boring hole elevation, and pertinent soils data.
- F. Foundation Plan and Details.

- G. Abutment Details.
- H. Pier Details.
- I. Beam or Girder Layout.
- J. Beam or Girder Details.
- K. Deck and Approach Slab Details.
- L. Pour Sequence and negative moment reinforcing for continuous bridges.
- M. Miscellaneous Bridge Details.
- N. Screed Elevations at span tenth points of each girder, each span.
- O. Canal Lining or Flood Protection Details.

The plans are to provide the bridge detail information in a consecutive order as the bridge structure is built. Avoid unnecessary repetition of information. All explanatory notes are to be written in plain English to be clearly understood by the construction crew. The above provided list and order of plan sheets is an example only. It can, and should be, modified as needed to accommodate the project size and complexity of the bridge structure.

#### **4.8.5 SUBMITTAL REQUIREMENTS AND PROCEDURES**

##### **4.8.5.1 Maricopa County Contracted Work**

Design development and submittals are to comply with the Project Development Manual.

##### **4.8.5.2 Permit Work (Not Maricopa County Contracted Work)**

Although not required, it is recommended that a meeting be held with the MCDOT Structural Design Branch during early plan development after preliminary structural layout and type of major bridge components have been selected. If ADOT standard drawings are used, this meeting is not generally needed. The meeting allows for interaction and feedback that will make the design and approval process more efficient.

For bridge structures to be constructed within MCDOT right-of-way submit the following:

1. A complete set of bridge plans compliant with section 4.8.4 (signed and sealed).
2. A complete geotechnical report (signed and sealed).
3. A complete drainage report (signed and sealed).
4. A complete set of bridge design computations unless an ADOT standard design is used (signed and sealed).
5. A bridge load rating report with ratings in both LFR and LRFR unless an ADOT standard design is used (signed and sealed).
6. Roadway plans and utility drawings (signed and sealed).

## **4.9 HAZARDOUS MATERIALS**

### **Originator: Engineering Division**

When the design requires the use of any materials at the project site that are hazardous substances which may be harmful to humans, animals, vegetation, ground and surface water, and the environment and/or are regulated under the Hazardous Material Transportation Act, the Toxic Substances Control Act, the Resources Conservation and Recovery Act, or the Comprehensive Environmental Response, Compensation, and Liability Act the Design Engineer shall clearly identify all such occurrences. Identification of hazardous substances shall be included on all affected drawings and in the Special Provisions. The Design Engineer shall provide in the Special Provisions a listing of the hazardous materials cross-referenced to the plans. The Special Provisions shall include information needed by the Contractor to comply with the Hazardous Material Handling specifications contained in the MAG Specifications as modified by the MCDOT Supplement (Section 107.5).

Asbestos-cement pipe is to be treated as a hazardous material. New installations of asbestos-cement pipe shall not be installed in Maricopa County right-of-way.

## **4.10 RIGHT-OF-WAY**

### **Originator: Engineering Division**

The design plans shall identify right-of-way and easement requirements. The plans shall show and dimension existing right-of-way, new right-of-way, and easements. The type of each easement shall be shown on the plans.

For MCDOT TIP projects, the Design Engineer shall furnish a MicroStation drawing to MCDOT showing existing and new right-of-way in accordance with the current edition of the MCDOT CAD Standards.

On MCDOT TIP projects the Design Engineer shall include all necessary right-of-way and easement requirements (including for utility company and other private facility relocations) on the Preliminary Design (60%) Submittal. All new right-of-way and easement requirements shown on the 60% plans will be considered final, and will not be revised without the prior approval of the MCDOT Engineering Division Manager.

### **RIGHT-OF-WAY DOCUMENTS**

For all MCDOT capital projects, the title reports, legal descriptions, final project right-of-way strip maps, and related items will be MCDOT's responsibility, unless otherwise specified in the project scope of work.

## **4.11 UTILITIES AND IRRIGATION**

### **Originator: Engineering Division**

#### **4.11.1 IRRIGATION FACILITIES**

Private irrigation and irrigation district facilities other than those belonging to the Salt River Project (SRP) will be designed with the irrigation owner's approval and incorporated into the project construction drawings. Unless otherwise directed, all private irrigation facilities shall be located outside of the right-of-way.

For MCDOT's capital projects private irrigation relocation shall be designed on a replace-in-kind basis; the initial contact with the owner or irrigator will be made through MCDOT with the Design Engineer responsible for all necessary engineering and subsequent coordination. The Design Engineer shall keep the MCDOT Engineering Utility Coordinator informed of all irrigation related meetings and provide copies of all irrigation meeting minutes and correspondence to the MCDOT Engineering Utility Coordinator and Project Manager.

Whenever possible, the design of irrigation district facility relocations will take into account the ultimate future roadway section so that future relocations will not be necessary.

SRP facility improvements shall be referenced and shown on construction plans using MAG standard symbols wherever applicable. The improvement plans shall be coordinated with the SRP final plans.

#### **4.11.2 UTILITIES**

Relocation of existing utilities shall be avoided, except where necessary due to construction or drainage requirements. Design of culverts, irrigation facilities, and/or storm drain systems should avoid or minimize any disruption of utility service.

The location of existing and new underground utilities and culverts shall be shown on the paving plans, paving profiles, culvert profiles, storm drain profiles, private irrigation profiles, cross-sections, and other locations where a potential utility conflict may occur.

All above ground utilities and signal poles shall be offset behind future sidewalk in urban areas. In rural and urban areas, new or relocated above ground utilities shall be located as close to the right-of-way line as is practical.

Utility manhole frames and covers, clean outs, and valve boxes shall not be located in any curb ramp, curb, or gutter.

**TABLE 4.1: MINIMUM COVER DEPTH FOR UNDERGROUND UTILITIES<sup>1</sup>**

Description	Arterial Street	Collector Street	Local Street & Alley	Unpaved (No Curb & Gutter)
<b>4-POWER</b>				
0-600 Volts	36"	36"	24"	48"
601-7200 Volts	42"	42"	42"	54"
12KV (local dist)	42"	42"	42"	54"
12KV (30 feeder)	48"	48"	48"	60"
Street Light Circuit	36"	36"	36"	48"
<b>GAS</b>				
Low Pressure Gas (60PSI and below)	36"	36"	36"	48"
High Pressure Gas (60PSI and above)	48"	48"	48"	60"
<b>WATER / IRRIGATION / STORM DRAIN</b>				
Water Line > 12" diameter	48"	48"	48"	60"
Water Line < 12" diameter	36"	36"	36"	48"
Irrigation Lines	36"	36"	36"	48"
Storm Drain Lines	18"	18"	18"	30"
<b>TELECOMMUNICATIONS</b>				
Fiber Optic	48" <sup>2</sup>	48"	48"	60"
Copper Cable	36" <sup>3</sup>	36"	36"	48"
Copper / Fiber Service Drops	36"	36"	36"	48"
<b>CATV</b>				
Fiber Optic	48" <sup>1</sup>	48"	48"	60"
Coaxial Cable	36" <sup>2</sup>	36"	36"	48"
Coaxial Service Drops	36"	36"	36"	48"

**NOTE:**

- MCDOT may approve deviations from these standards under unusual and compelling circumstances.
- All roadway crossings must be within conduit.
- All non-metallic facilities must be accompanied by a tracer wire.
- Cover is defined as the difference in elevation between the top of the line or pipe and the ultimate gutter grade of the roadway if paving will follow or to top of existing pavement.
- For facilities outside of the proposed or existing roadway limits cover is defined as the difference in elevation between the top of the line or pipe and the natural or regraded ground surface, whichever is less.

<sup>1</sup> Minimum depths should comply with current regulatory standards if different than those show in Table 4.1.

<sup>2</sup> With warning tape, 60" depth when crossing or within fifteen feet (15') of roadway.

<sup>3</sup> If direct buried, must be fifteen feet (15') beyond the edge of roadway.

### 4.11.3 COORDINATION WITH UTILITIES AND MUNICIPALITIES

Close coordination with utility owners is very important to roadway projects to insure timely relocations. The Design Engineer shall research utility information, determine the location and ownership of all utilities within the project limits and resolve each design issue associated with utilities. When two or more utility owners having the same type of facility within the project limits, the plans shall indicate the owner associated with each installation. The construction documents shall clearly identify the ownership of all utilities within the project limits.

For MCDOT capital projects, following approval of each submittal, the Design Engineer or Utility Coordinator shall furnish plan sets for each utility and municipality impacted by the project. Plans will be distributed through the MCDOT Engineering Division. Direct contact with utility company engineers for design coordination and land conflict resolution will be initiated through the MCDOT Utility Coordinator within the Engineering Division. The Design Engineer shall record minutes of all meetings and provide MCDOT with copies of all minutes and correspondence directly received by the Design Engineer.

Requests for utility designation, potholing, and manhole invert elevations shall be submitted to the MCDOT Utility Coordinator. The requests shall be accompanied with a full sized set of plan drawings indicating locations by northing and easting and station and offset from centerline of new construction. Utility designation and potholing results shall be shown on the paving plans, paving profiles, culvert profiles, storm drain profiles, private irrigation profiles, cross-sections, and other locations where a potential utility conflict may occur.

The Design Engineer shall evaluate the existing utility company as-built plans and pothole data to determine conflict locations and notify the MCDOT Utility Coordinator of these locations. The Design Engineer shall provide utility conflict locations, preliminary utility company relocation designs, and any associated right-of-way or easement requirements (for utility relocations) shall be shown on the Preliminary Design (60%) plans noted above. Final utility relocation designs shall be included on the Final Design (95%) submittal plans. The sealed plans shall reflect the new utility locations and all other existing utility locations. Refer to the PDM for additional guidance on the project development and utility coordination on TIP projects.

## **4.12 TRAFFIC DESIGN**

### **Originator: Transportation Systems Management & Operations Division**

#### **SIGNING & PAVEMENT MARKINGS BASE MAPS AND DESIGN**

The MCDOT Pavement Marking Manual and MCDOT Signing Manual shall be used as guidance in preparation of signing and pavement marking plans. The MCDOT Signal Design Manual shall be referenced for the preparation of signal plans.

For MCDOT capital projects, the Design Engineer shall furnish base maps for signing and pavement markings design and traffic signal design in accordance with the MCDOT CAD Standards, unless otherwise directed by the MCDOT Transportation Systems Management and Operations Division. Sealed pavement markings, signing or signal sheets, when prepared by MCDOT, shall be incorporated by the Design Engineer into the construction plans.

## **4.13 EARTHWORK**

### **Originator: Engineering Division**

The establishment of profile grades shall consider existing terrain, existing and future improvements, drainage, construction economics, and other factors. Balanced earthwork is desirable, but may not be practical. If deemed necessary by MCDOT, the Design Engineer shall adjust grades and recalculate earthwork to obtain a solution that reflects both good engineering judgment and practical construction economics. Earthwork calculations shall be submitted to MCDOT.

For MCDOT capital projects, earthwork calculations shall use the soil factors identified in the geotechnical investigation report and an earthwork calculation program acceptable to MCDOT. Earthwork calculations and cross sections shall be submitted with the first review and as requested thereafter. The work associated with revising earthwork calculations is included in the basic contract fee.

Additional information and requirements is provided with the MCDOT Earthwork Guidelines that are available at:

<https://www.maricopa.gov/DocumentCenter/View/69452/Earthwork-Guidelines-PDF>

# **Chapter 5**

## **Geometric Design Standards**

**TABLE OF CONTENTS**

**CHAPTER 5 GEOMETRIC DESIGN STANDARDS**

**5.1 CROSS SECTIONS.....5-1**  
     5.1.1 LANE WIDTHS ..... 5-1  
     5.1.2 CROSS SLOPE..... 5-2

**5.5 DESIGN SPEEDS.....5-18**

**5.10 HORIZONTAL CURVES .....5-20**  
     5.10.1 GENERAL CONTROLS..... 5-20  
     5.10.2 SUPERELEVATION RATES..... 5-21  
     5.10.3 INTERSECTION CURVES ..... 5-22  
     5.10.4 SUPERELEVATION TRANSITION ..... 5-22  
     5.10.5 SIGHT DISTANCE ON HORIZONTAL CURVES..... 5-23

**5.11 VERTICAL ALIGNMENT .....5-25**  
     5.11.1 VERTICAL CURVES ..... 5-25  
     5.11.2 GRADES..... 5-25  
     5.11.3 CREST VERTICAL CURVES..... 5-26  
     5.11.4 PASSING SIGHT DISTANCE ON CREST VERTICAL CURVES..... 5-28  
     5.11.5 SAG VERTICAL CURVES ..... 5-28  
     5.11.6 GENERAL CONTROLS..... 5-29

**5.12 HIGHWAY ALIGNMENT.....5-31**

**5.15 STOPPING SIGHT DISTANCES .....5-32**

**5.20 TRANSITION TAPERS .....5-33**  
     5.20.1 NARROWING TRANSITIONS ..... 5-33  
     5.20.2 WIDENING TRANSITIONS..... 5-33  
     5.20.3 TRANSITION GEOMETRICS ..... 5-33

**5.25 CLEAR ZONES.....5-34**  
     5.25.1 GENERAL CRITERIA ..... 5-34  
     5.25.2 OBSTACLES..... 5-34  
     5.25.3 EMBANKMENTS..... 5-35  
     5.25.4 CLEAR ZONE WIDTH ..... 5-35  
     5.25.5 VERTICAL CLEARANCE..... 5-36

**5.30 GUARDRAIL.....5-37**  
     5.30.1 PURPOSE..... 5-37  
     5.30.2 TYPE..... 5-37  
     5.30.3 PLACEMENT..... 5-37  
     5.30.7 LENGTH..... 5-38

<b>5.35</b>	<b>PAVEMENT EDGE TREATMENTS .....</b>	<b>5-39</b>
	5.35.1 SAFETY EDGE.....	5-39
	5.35.2 ASPHALT THICKENED EDGE .....	5-39
	5.35.3 CURBS .....	5-39
	5.35.4 CURB RETURNS .....	5-40
	5.35.5 CUTOFF WALLS .....	5-40
<b>5.36</b>	<b>SIDEWALKS .....</b>	<b>5-41</b>
	5.36.1 GENERAL.....	5-41
	5.36.2 DETECTABLE WARNINGS .....	5-41
	5.36.3 CURB RAMPS .....	5-42
<b>5.37</b>	<b>GEOMETRIC STANDARDS FOR PARK ROADS.....</b>	<b>5-43</b>

**LIST OF TABLES**

TABLE 5.1: LANE WIDTHS .....	5-1
TABLE 5.2: MINIMUM DESIGN SPEEDS FOR RURAL ROADWAYS.....	5-18
TABLE 5.3: MINIMUM DESIGN SPEEDS FOR URBAN ROADWAYS .....	5-19
TABLE 5.4: MINIMUM RADII FOR LOCAL RESIDENTIAL STREETS .....	5-21
TABLE 5.5: MINIMUM RADII FOR INTERSECTION CURVES .....	5-22
TABLE 5.6: DESIGN SPEED AND RELATIVE PROFILE GRADIENTS.....	5-23
TABLE 5.7: MAXIMUM VERTICAL GRADES (%).....	5-26
TABLE 5.8: SIGHT DISTANCE DESIGN PARAMETERS FOR CREST VERTICAL CURVES.....	5-27
TABLE 5.9: DESIGN CONTROLS FOR CREST VERTICAL CURVES.....	5-28
TABLE 5.10: DESIGN CONTROLS FOR SAG VERTICAL CURVES .....	5-29
TABLE 5.11: PASSING AND STOPPING SIGHT DISTANCES .....	5-32
TABLE 5.12: GRADE ADJUSTED STOPPING SIGHT DISTANCES.....	5-32

**LIST OF FIGURES**

FIGURE 5.1 - RURAL PARKWAY .....	5-3
FIGURE 5.2 - RURAL PRINCIPAL ARTERIAL.....	5-4
FIGURE 5.3 - RURAL MINOR ARTERIAL .....	5-5
FIGURE 5.4 - RURAL MAJOR COLLECTOR .....	5-6
FIGURE 5.5 - RURAL MINOR COLLECTOR .....	5-7
FIGURE 5.6 - RURAL LOCAL ROADS .....	5-8
FIGURE 5.7 – URBAN PARKWAY.....	5-9
FIGURE 5.8 - URBAN PRINCIPAL ARTERIAL .....	5-10
FIGURE 5.9 - URBAN MINOR ARTERIAL.....	5-11
FIGURE 5.10 - URBAN MAJOR COLLECTOR.....	5-12
FIGURE 5.11 - URBAN MINOR COLLECTOR.....	5-13
FIGURE 5.12 - URBAN LOCAL RESIDENTIAL ROAD .....	5-14
FIGURE 5.13 - URBAN FRONTAGE ROAD (RESIDENTIAL) .....	5-15
FIGURE 5.14 - INDUSTRIAL/COMMERCIAL SUBDIVISION ROADS .....	5-16
FIGURE 5.15 - SUPERELEVATED CROSS SECTIONS.....	5-17
FIGURE 5.16 – HORIZONTAL SIGHT LINE OFFSET .....	5-24

## **5.1 CROSS SECTIONS**

### **Originator: Engineering and Transportation Systems Management & Operations Divisions**

Cross sections for roadways per functional classifications are provided in Figures 5.1 through 5.14. Special use cross sections for superelevation conditions are provided in Figure 5.15. For roads with a near-term likelihood of being annexed by another city or town, the County may incorporate the city or town's road standards into the Design Standards as the County sees fit.

#### **5.1.1 LANE WIDTHS**

Consult the standard cross sections (Figures 5.1 through 5.14) for standard lane widths and other relevant cross section geometry. For analyzing non-typical situations, Table 5.1 shows appropriate ranges of roadway lane and shoulder widths. If severe constraints make preferred widths too costly, then the 'minimum' values are to be used as an absolute minimum. The Design Engineer must get prior approval from MCDOT Engineering Division before using the 'minimum' values. The Design Engineer shall prepare a design memo detailing the cross section and lane widths. All dimensions are in feet and measured to center of lane lines.

The length of the transition to match the standard cross section must be determined using the road width transition tapers as specified in the standards (Chapter 5, Section 20, "Transition Tapers").

<b>TABLE 5.1: LANE WIDTHS</b>		
<b>Lane Type</b>	<b>Preferred Width (feet)</b>	<b>Minimum Width (feet)</b>
Parking Lane	10	8
Right Through Lane Without Curb	12	11
Right Through Lane With Curb and Without Bike Lane	14	12
Right Through Lane With Curb and With Bike Lane	12	12
Left Through Lane With Median Curb	12	12
Other Through Lanes	12	11
Painted Center TWLTL**	14	12
Left Turn Lane	12	11
Right Turn Lane Without Curb	12	10
Right Turn Lane With Curb	14	12
Shoulder***	12	10
Bike Lane with 1'-5" gutter pan	6	6
Bike Lane without gutter pan	6	6
NOTE: Outside lane width is measured to face of curb. ** Two-way left turn lane. *** Shoulder width includes paved and graded portions of shoulder.		

### 5.1.2 CROSS SLOPE

The desired cross slope on all pavement types is 0.02 foot per foot, with 0.01 foot per foot as the desired minimum and 0.03 foot per foot as the desired maximum. Pavement cross slopes at signalized intersections may be reduced to 0.005 foot per foot to obtain intersection profiles compliant with design speed requirements. Changes in pavement cross slope shall be accomplished using transition sections with edge of pavement profile gradients the same as required for superelevation transitions (see Section 5.10.4).

Inverted crown designs are prohibited. When pavements are resurfaced the cross slopes should be kept within the above limits.

Graded shoulders except rural local roads should slope 0.05 foot per foot (20:1) downward from the adjacent pavement edge. For rural local roads the graded shoulders should slope 0.10 foot per foot (10:1) away from the adjacent pavement.

The paved portions of the shoulders shall be constructed as an integral part of the travel lanes and have the same cross slope and structural section as the traveled lanes. The remaining unpaved portion of the shoulder is to comply with the graded shoulder requirements.

In superelevated sections, the graded shoulder cross slope shall continue to slope away from the pavement. The graded shoulder cross slope on the high side may be reduced to limit the roll-over grade break. The slope on the low side shall remain at the standard shoulder cross slope until the superelevation rate exceeds the standard shoulder slope, in which case the low side graded shoulder slope shall match the superelevation slope. The grade break between the pavement and the graded portion of the shoulder is the algebraic difference of the cross slope rates. The maximum algebraic difference allowed at the grade break is 8.0%. For superelevated pavements greater than 3% but less than 6% the graded portion of shoulder on the high side shall vary from 5% to 2% to maintain a maximum algebraic grade difference of 8%. For superelevated pavements greater than 6% maintain a maximum algebraic grade difference of 8%. When the cross slope of the graded portion of shoulder is sloped less than 2% away from the roadway pavement or slopes toward the roadway pavement then the shoulder area shall receive a bituminous stabilization treatment or asphalt concrete surface. See Figure 5.15, Superelevated Cross Section.

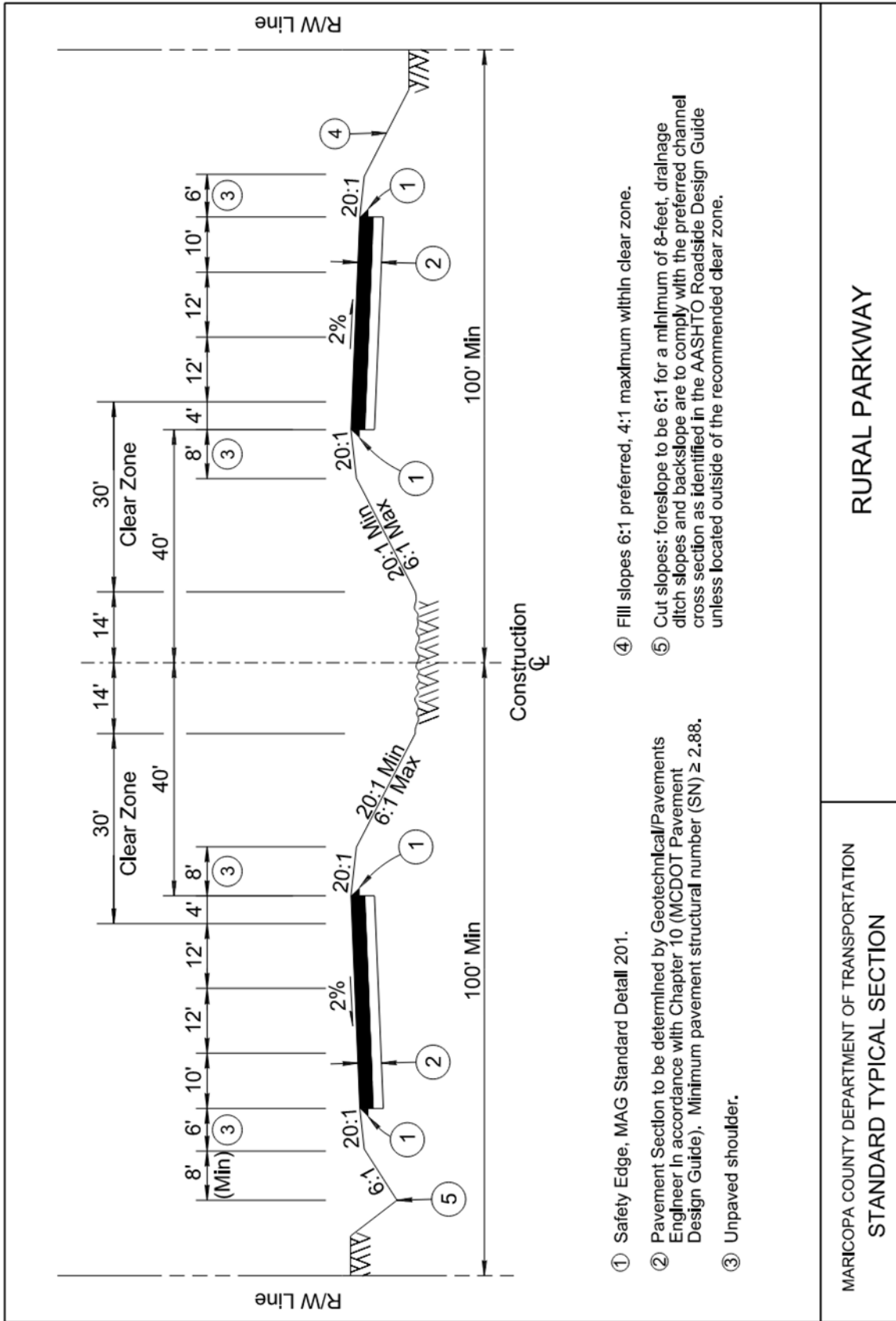


FIGURE 5.1 - RURAL PARKWAY

- ① Safety Edge, MAG Standard Detail 201.
- ② Pavement Section to be determined by Geotechnical/Pavements Engineer in accordance with Chapter 10 (MCDOT Pavement Design Guide). Minimum pavement structural number (SN)  $\geq 2.88$ .
- ③ Unpaved shoulder.
- ④ Fill slopes 6:1 preferred, 4:1 maximum within clear zone.
- ⑤ Cut slopes: foreslope to be 6:1 for a minimum of 8-feet, drainage ditch slopes and backslope are to comply with the preferred channel cross section as identified in the AASHTO Roadside Design Guide unless located outside of the recommended clear zone.

MARICOPA COUNTY DEPARTMENT OF TRANSPORTATION  
STANDARD TYPICAL SECTION

RURAL PARKWAY

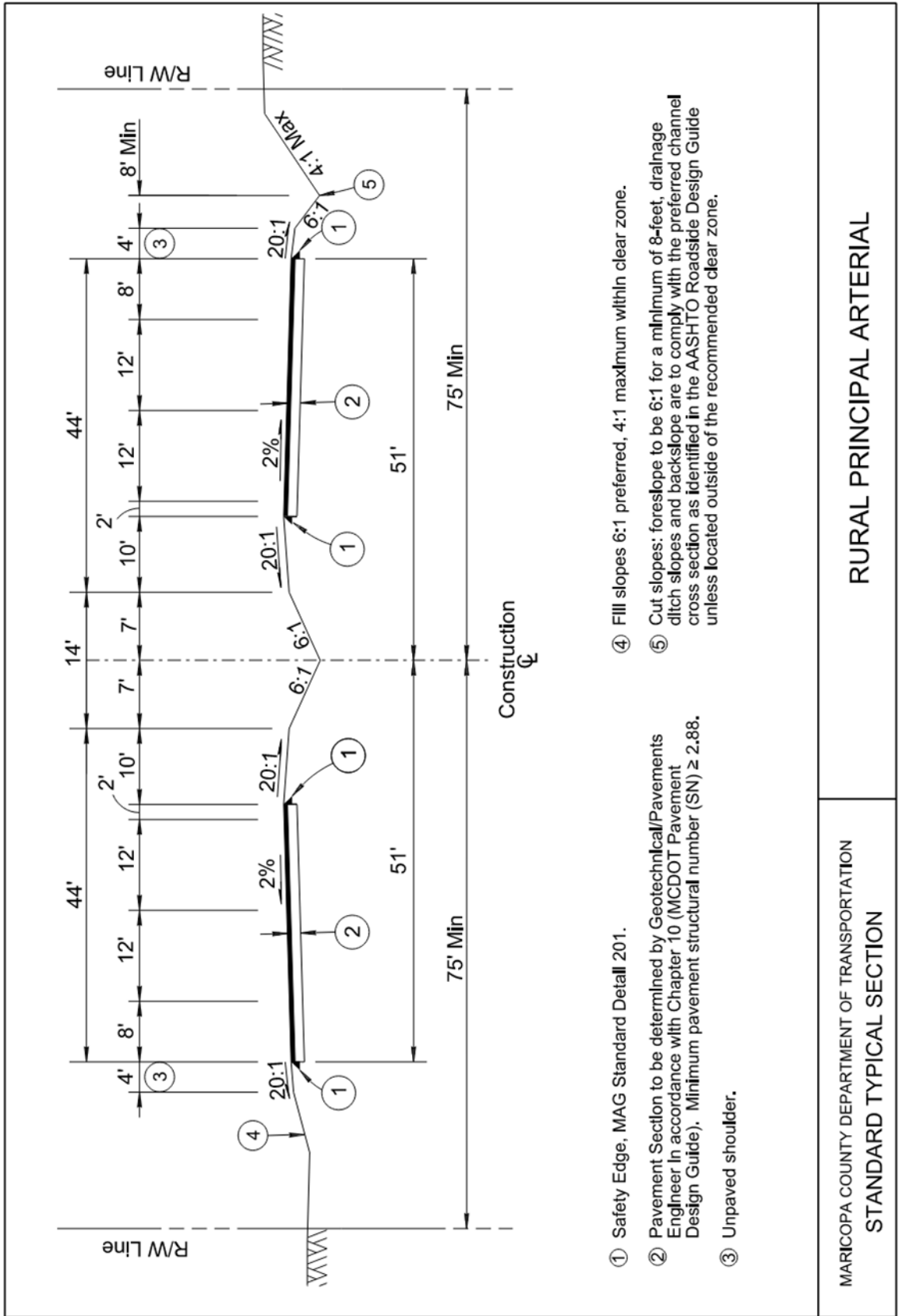


FIGURE 5.2 - RURAL PRINCIPAL ARTERIAL

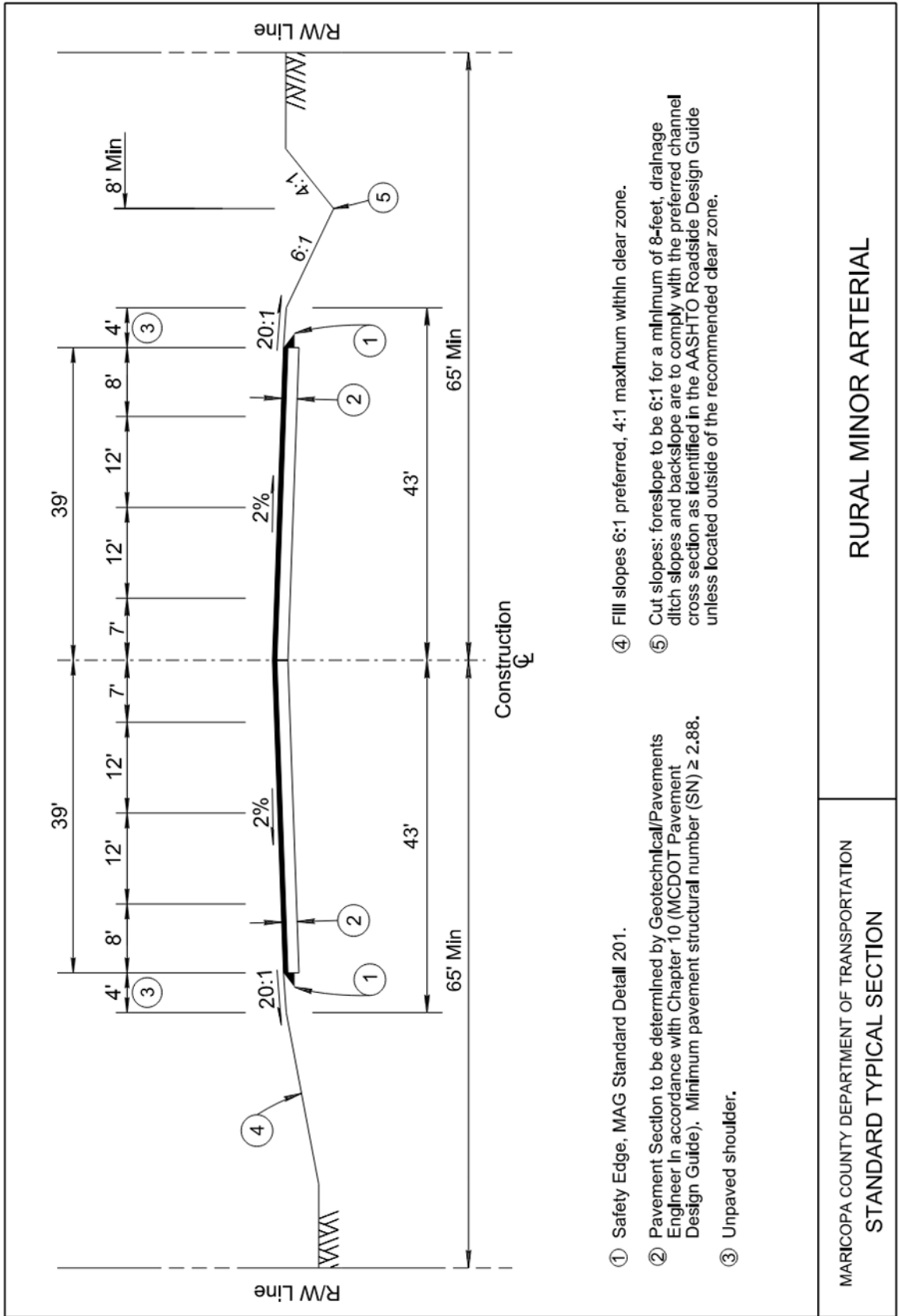


FIGURE 5.3 - RURAL MINOR ARTERIAL

MARICOPA COUNTY DEPARTMENT OF TRANSPORTATION  
STANDARD TYPICAL SECTION

RURAL MINOR ARTERIAL

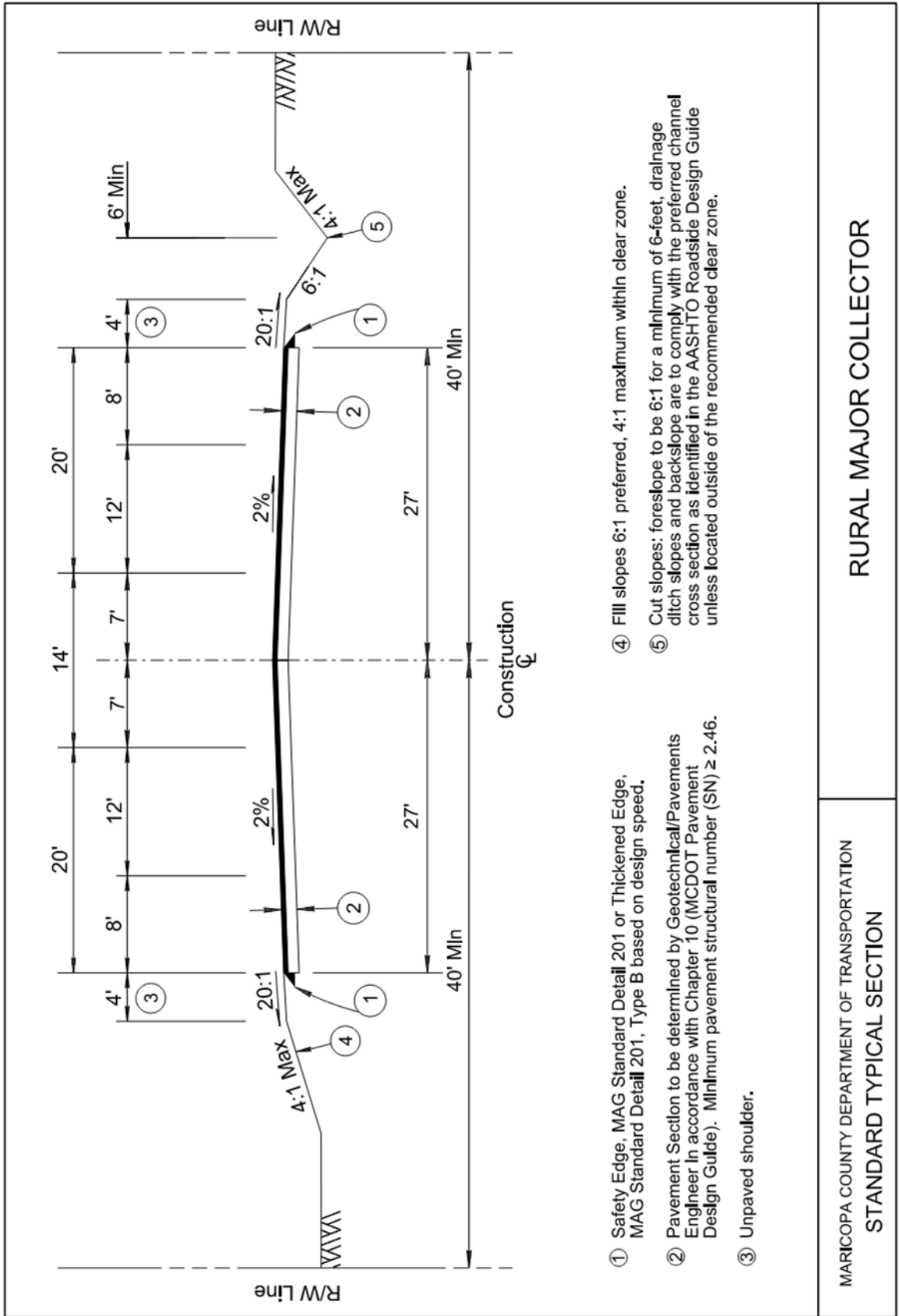
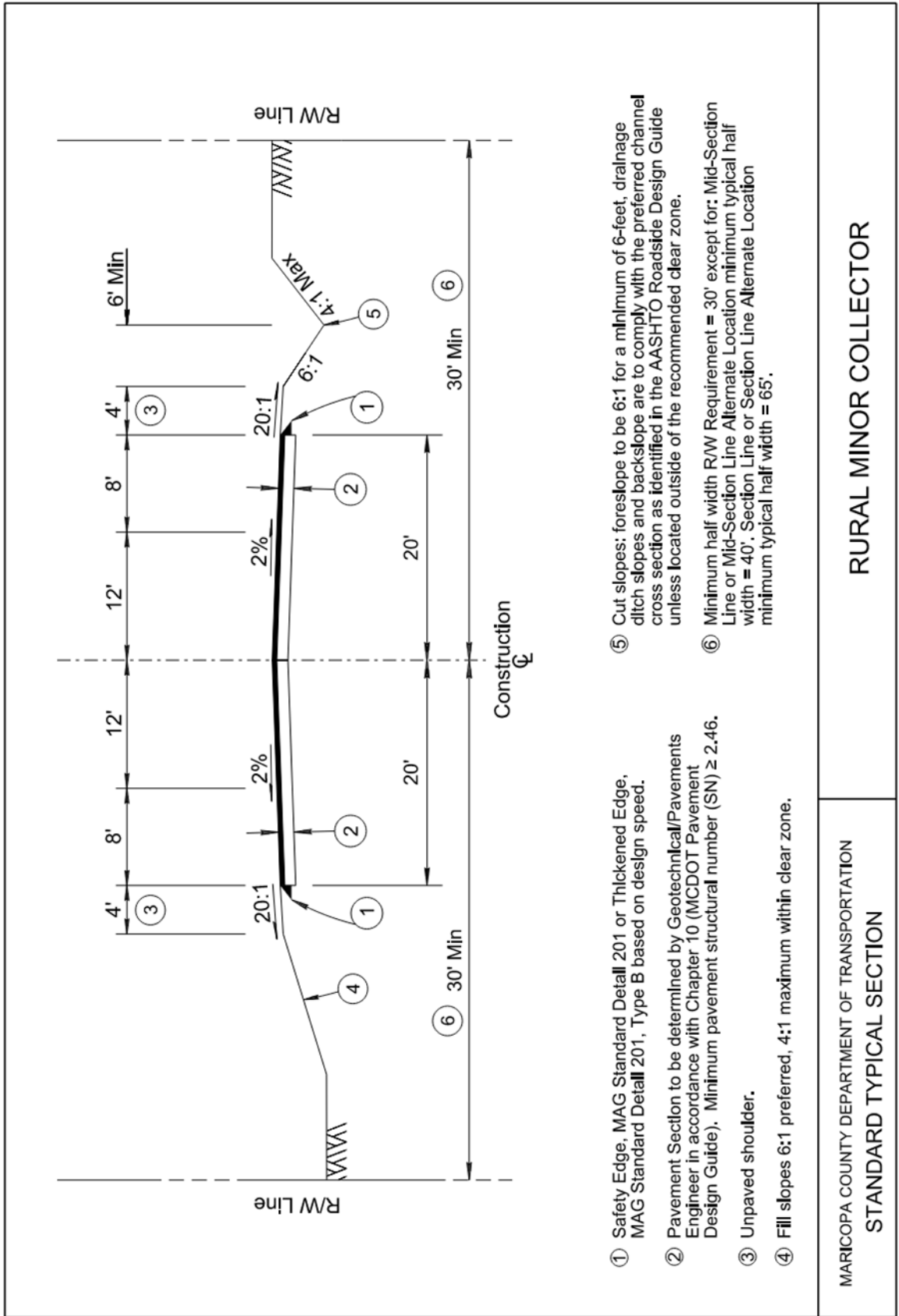


FIGURE 5.4 - RURAL MAJOR COLLECTOR

- ① Safety Edge, MAG Standard Detail 201 or Thickened Edge, MAG Standard Detail 201, Type B based on design speed.
- ② Pavement Section to be determined by Geotechnical/Pavements Engineer in accordance with Chapter 10 (MCDOT Pavement Design Guide). Minimum pavement structural number (SN)  $\geq$  2.46.
- ③ Unpaved shoulder.
- ④ Fill slopes 6:1 preferred, 4:1 maximum within clear zone.
- ⑤ Cut slopes: foreslope to be 6:1 for a minimum of 6-feet, drainage ditch slopes and backslope are to comply with the preferred channel cross section as identified in the AASHTO Roadside Design Guide unless located outside of the recommended clear zone.

MARICOPA COUNTY DEPARTMENT OF TRANSPORTATION  
STANDARD TYPICAL SECTION

RURAL MAJOR COLLECTOR

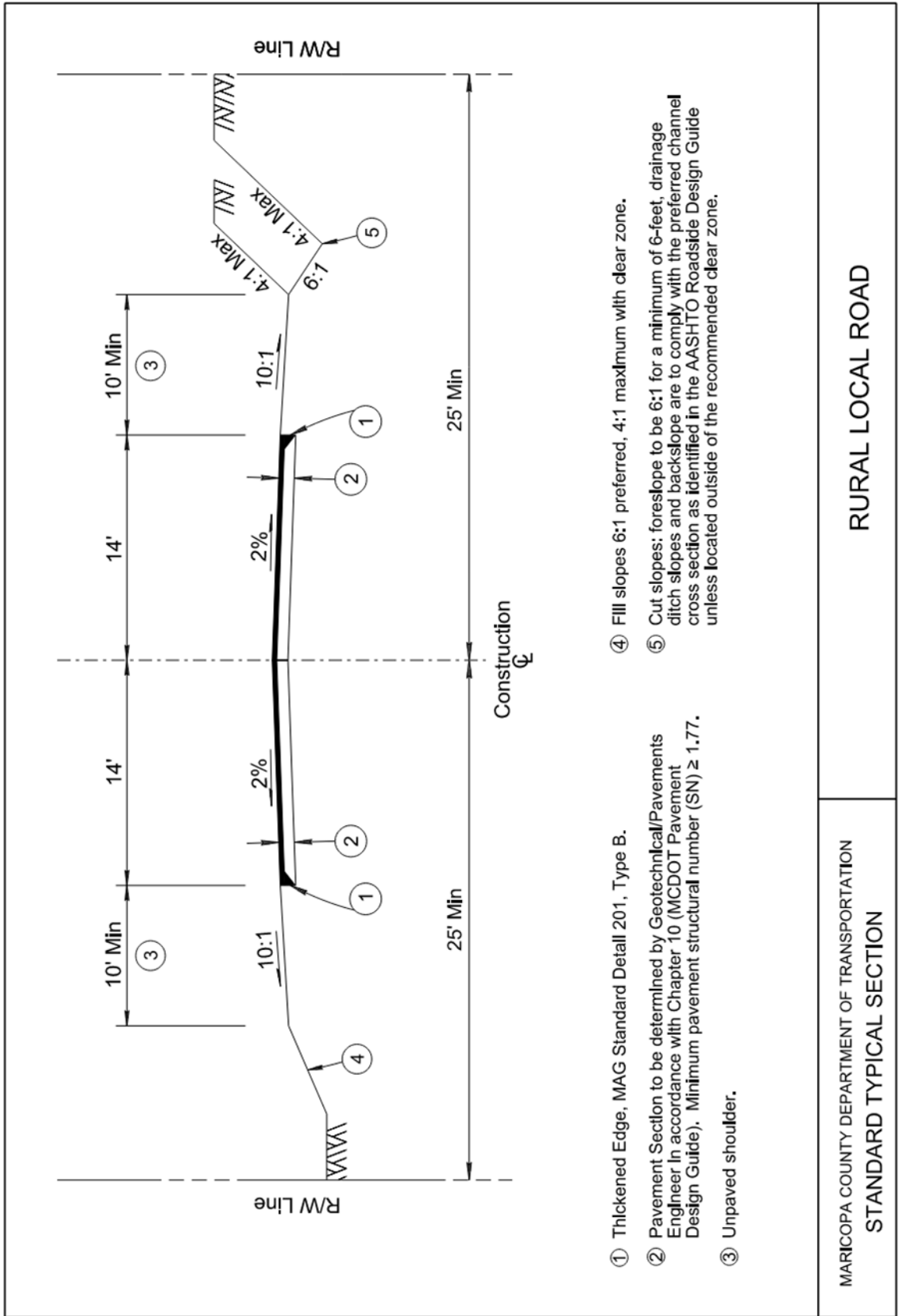


- ① Safety Edge, MAG Standard Detail 201 or Thickened Edge, MAG Standard Detail 201, Type B based on design speed.
- ② Pavement Section to be determined by Geotechnical/Pavements Engineer in accordance with Chapter 10 (MCDOT Pavement Design Guide). Minimum pavement structural number (SN)  $\geq$  2.46.
- ③ Unpaved shoulder.
- ④ Fill slopes 6:1 preferred, 4:1 maximum within clear zone.
- ⑤ Cut slopes: foreslope to be 6:1 for a minimum of 6-feet, drainage ditch slopes and backslope are to comply with the preferred channel cross section as identified in the AASHTO Roadside Design Guide unless located outside of the recommended clear zone.
- ⑥ Minimum half width RW Requirement = 30' except for: Mid-Section Line or Mid-Section Line Alternate Location minimum typical half width = 40'. Section Line or Section Line Alternate Location minimum typical half width = 65'.

FIGURE 5.5 - RURAL MINOR COLLECTOR

MARICOPA COUNTY DEPARTMENT OF TRANSPORTATION  
STANDARD TYPICAL SECTION

RURAL MINOR COLLECTOR

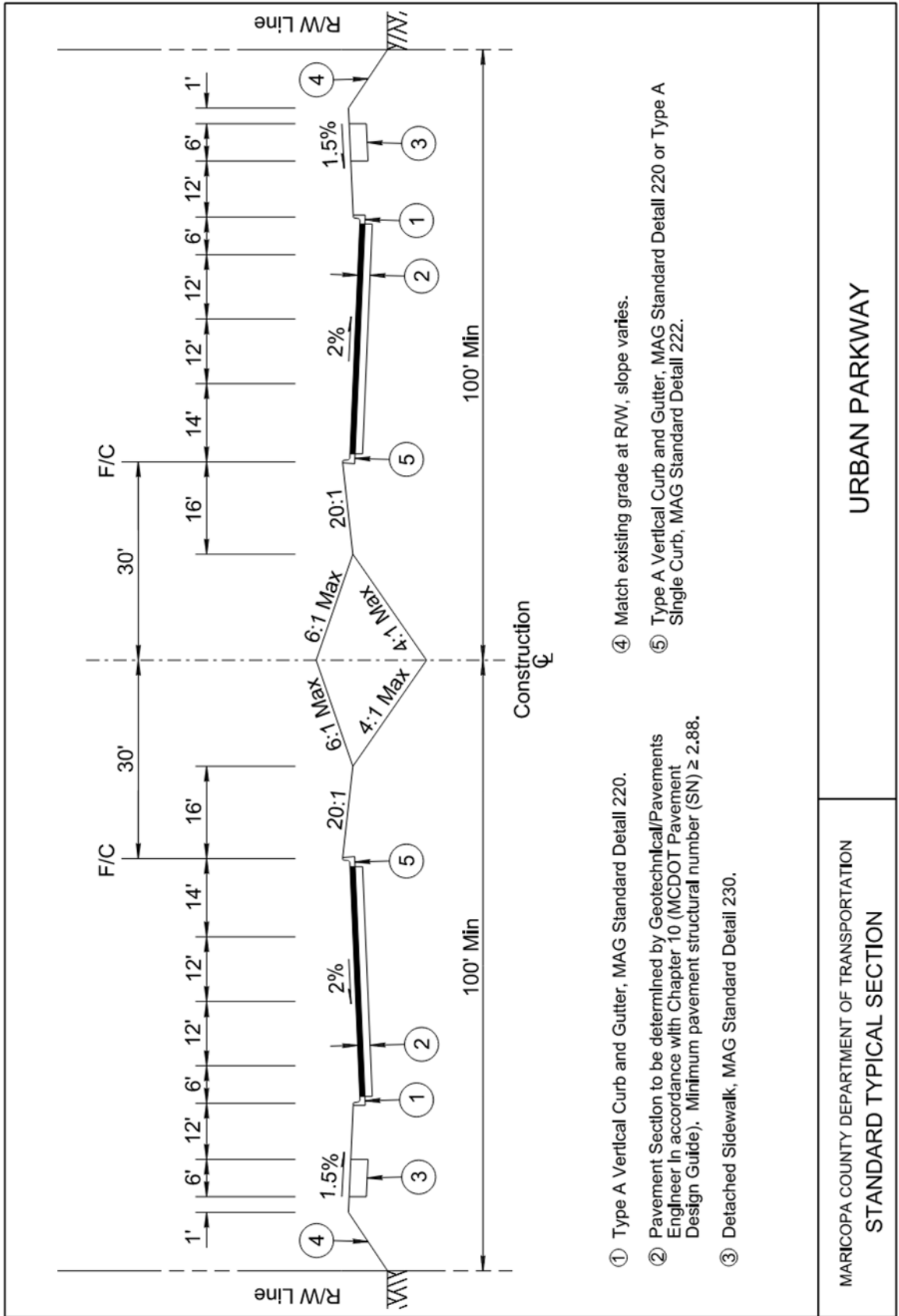


- ① Thickened Edge, MAG Standard Detail 201, Type B.
- ② Pavement Section to be determined by Geotechnical/Pavements Engineer in accordance with Chapter 10 (MCDOT Pavement Design Guide). Minimum pavement structural number (SN)  $\geq 1.77$ .
- ③ Unpaved shoulder.
- ④ Fill slopes 6:1 preferred, 4:1 maximum with clear zone.
- ⑤ Cut slopes: foreslope to be 6:1 for a minimum of 6-feet, drainage ditch slopes and backslope are to comply with the preferred channel cross section as identified in the AASHTO Roadside Design Guide unless located outside of the recommended clear zone.

MARICOPA COUNTY DEPARTMENT OF TRANSPORTATION  
STANDARD TYPICAL SECTION

RURAL LOCAL ROAD

FIGURE 5.6 - RURAL LOCAL ROADS



- ① Type A Vertical Curb and Gutter, MAG Standard Detail 220.
- ② Pavement Section to be determined by Geotechnical/Pavements Engineer in accordance with Chapter 10 (MCDOT Pavement Design Guide). Minimum pavement structural number (SN) ≥ 2.88.
- ③ Detached Sidewalk, MAG Standard Detail 230.
- ④ Match existing grade at R/W, slope varies.
- ⑤ Type A Vertical Curb and Gutter, MAG Standard Detail 220 or Type A Single Curb, MAG Standard Detail 222.

MARICOPA COUNTY DEPARTMENT OF TRANSPORTATION  
STANDARD TYPICAL SECTION

URBAN PARKWAY

FIGURE 5.7 – URBAN PARKWAY

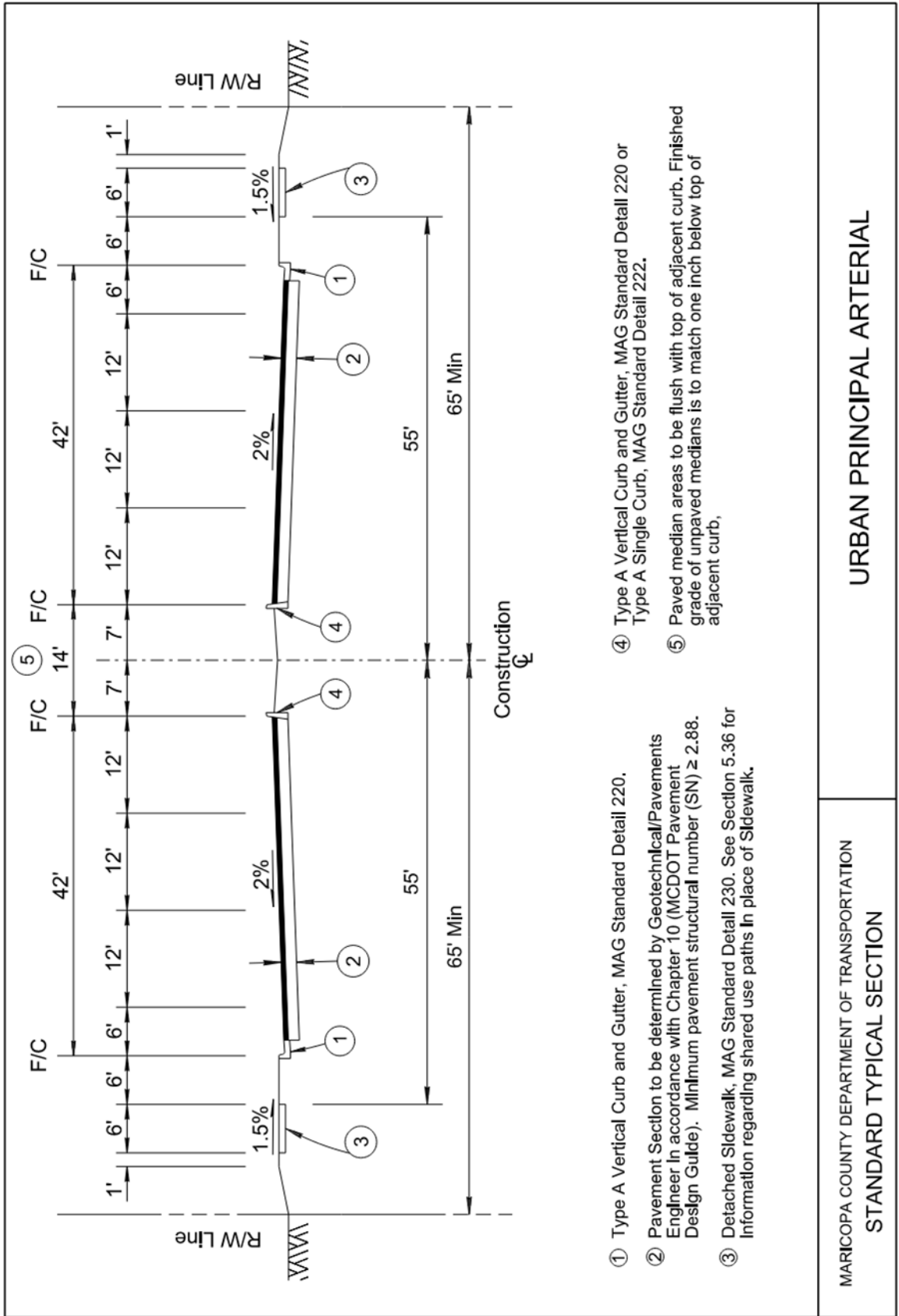


FIGURE 5.8 - URBAN PRINCIPAL ARTERIAL

- ① Type A Vertical Curb and Gutter, MAG Standard Detail 220.
- ② Pavement Section to be determined by Geotechnical/Pavements Engineer in accordance with Chapter 10 (MCDOT Pavement Design Guide). Minimum pavement structural number (SN)  $\geq 2.88$ .
- ③ Detached Sidewalk, MAG Standard Detail 230. See Section 5.36 for Information regarding shared use paths in place of Sidewalk.
- ④ Type A Vertical Curb and Gutter, MAG Standard Detail 220 or Type A Single Curb, MAG Standard Detail 222.
- ⑤ Paved median areas to be flush with top of adjacent curb. Finished grade of unpaved medians is to match one inch below top of adjacent curb.

MARICOPA COUNTY DEPARTMENT OF TRANSPORTATION  
STANDARD TYPICAL SECTION

URBAN PRINCIPAL ARTERIAL

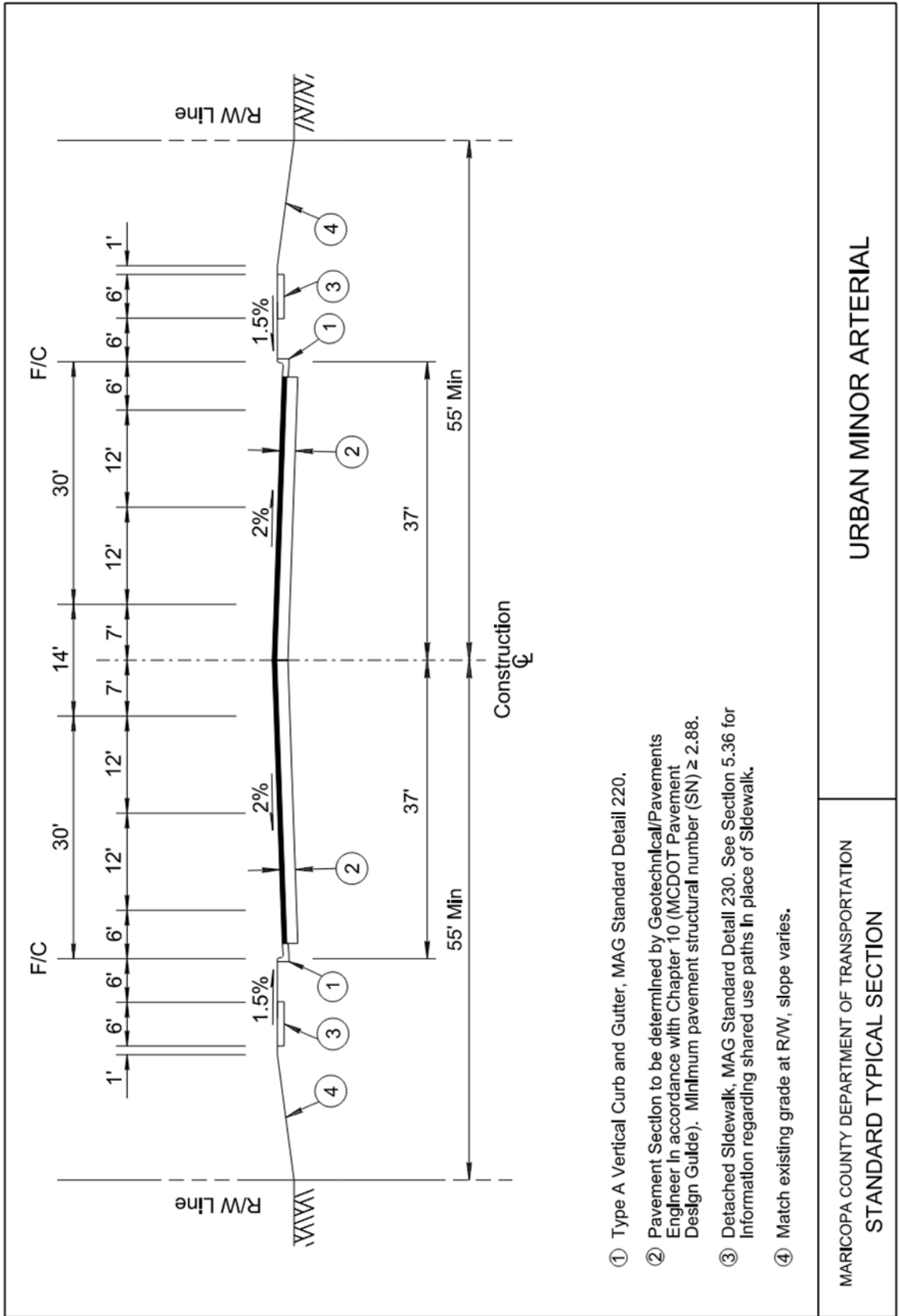


FIGURE 5.9 - URBAN MINOR ARTERIAL

MARICOPA COUNTY DEPARTMENT OF TRANSPORTATION  
STANDARD TYPICAL SECTION

URBAN MINOR ARTERIAL



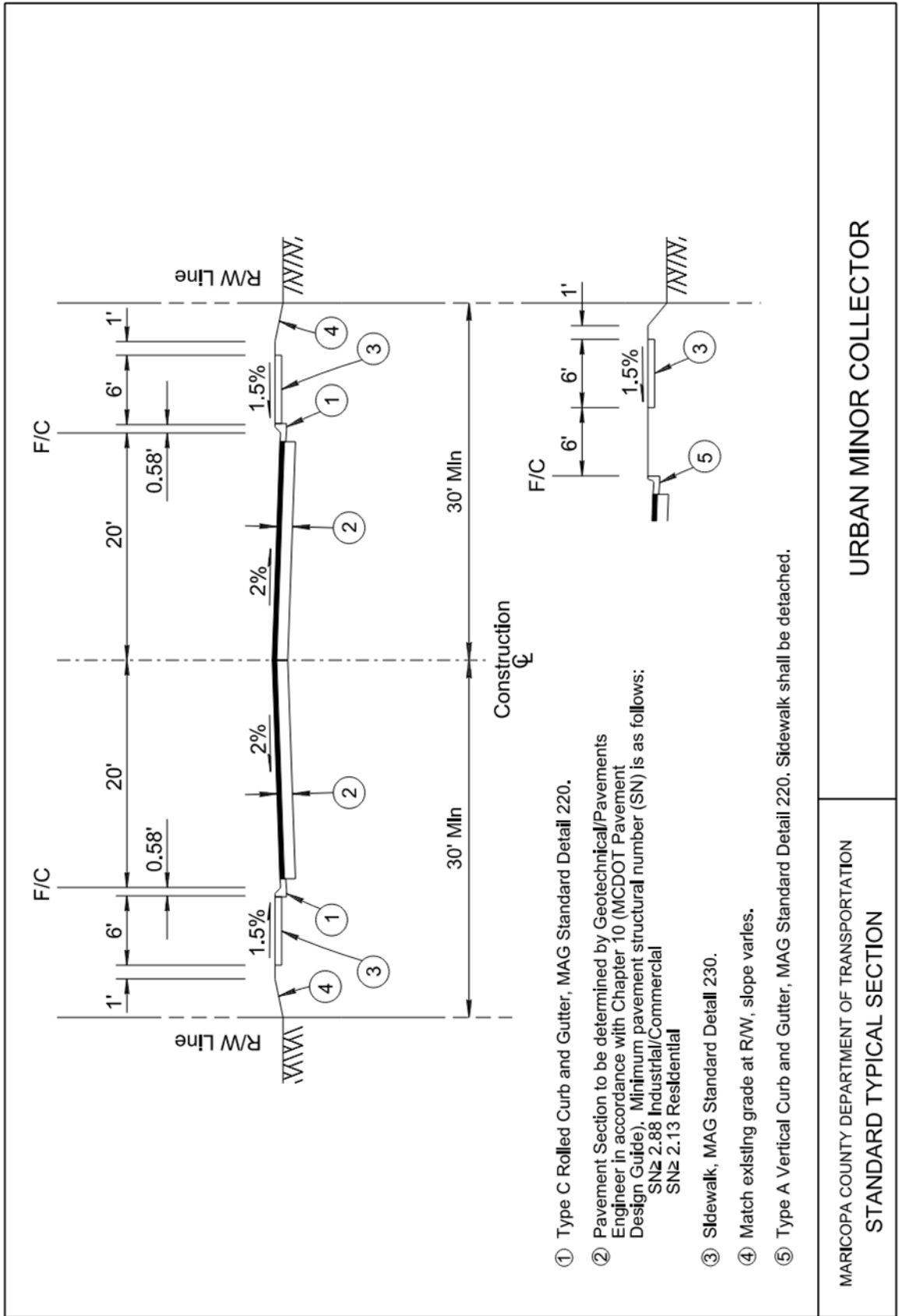


FIGURE 5.11 - URBAN MINOR COLLECTOR

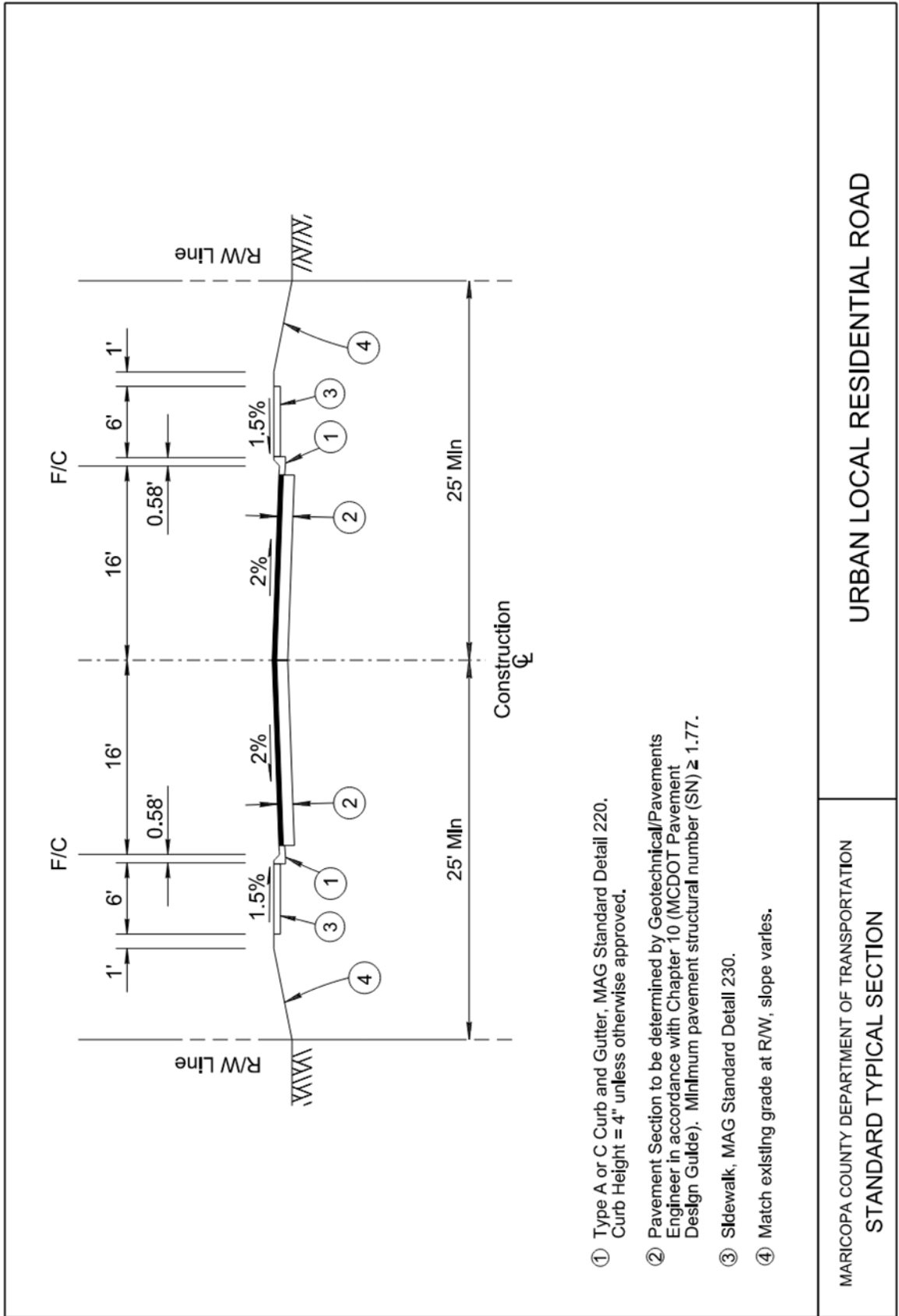


FIGURE 5.12 - URBAN LOCAL RESIDENTIAL ROAD

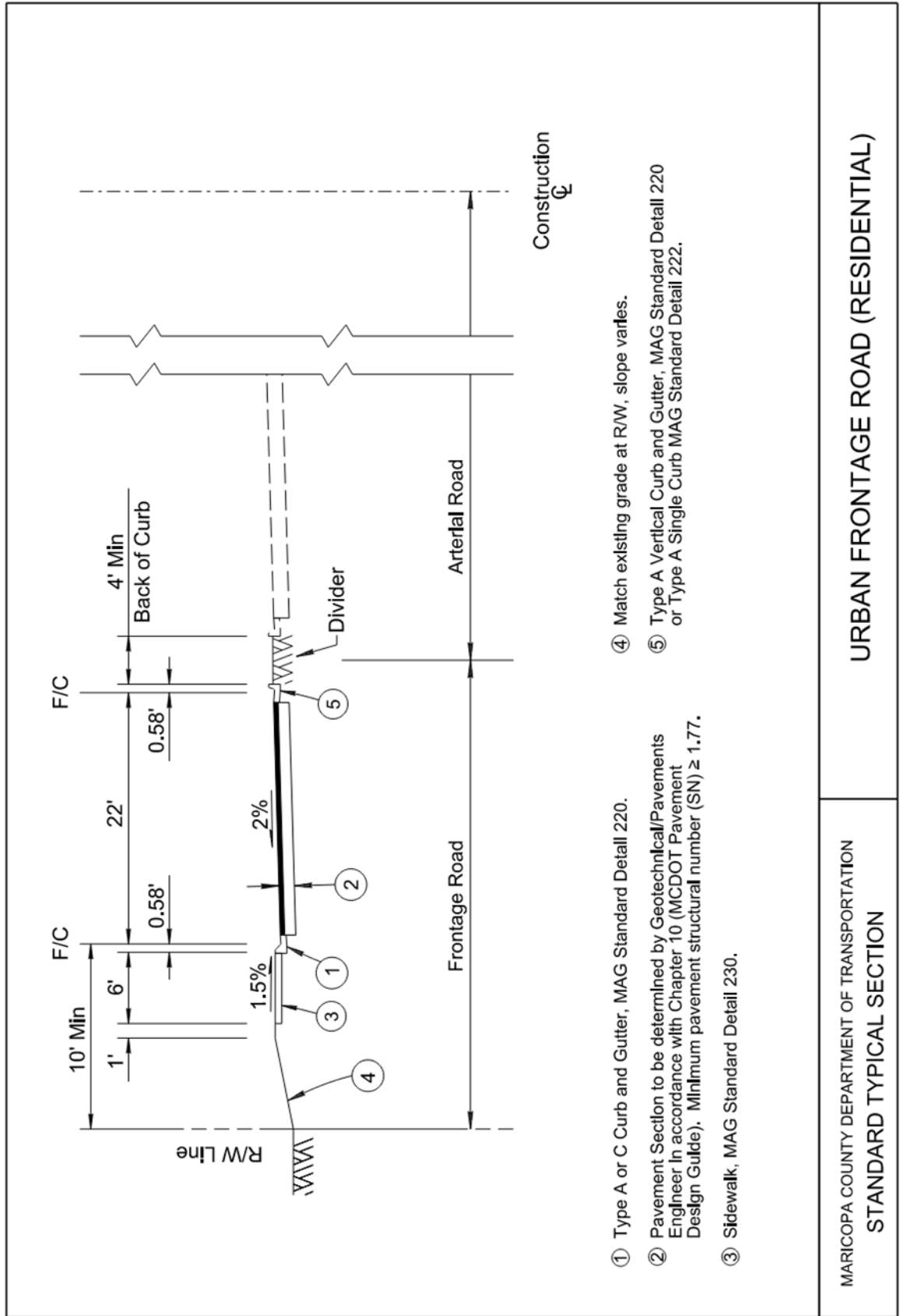
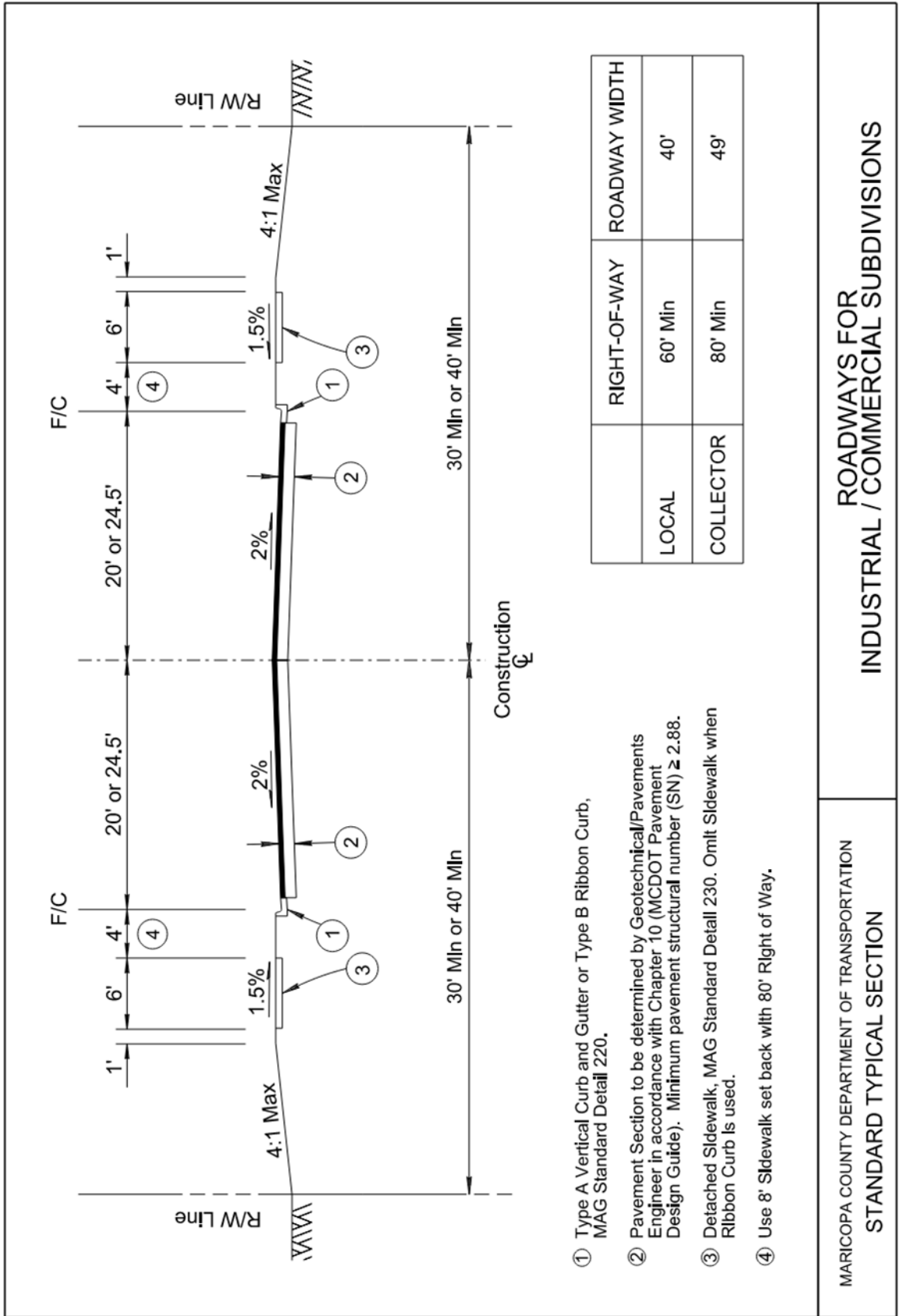


FIGURE 5.13 - URBAN FRONTAGE ROAD (RESIDENTIAL)

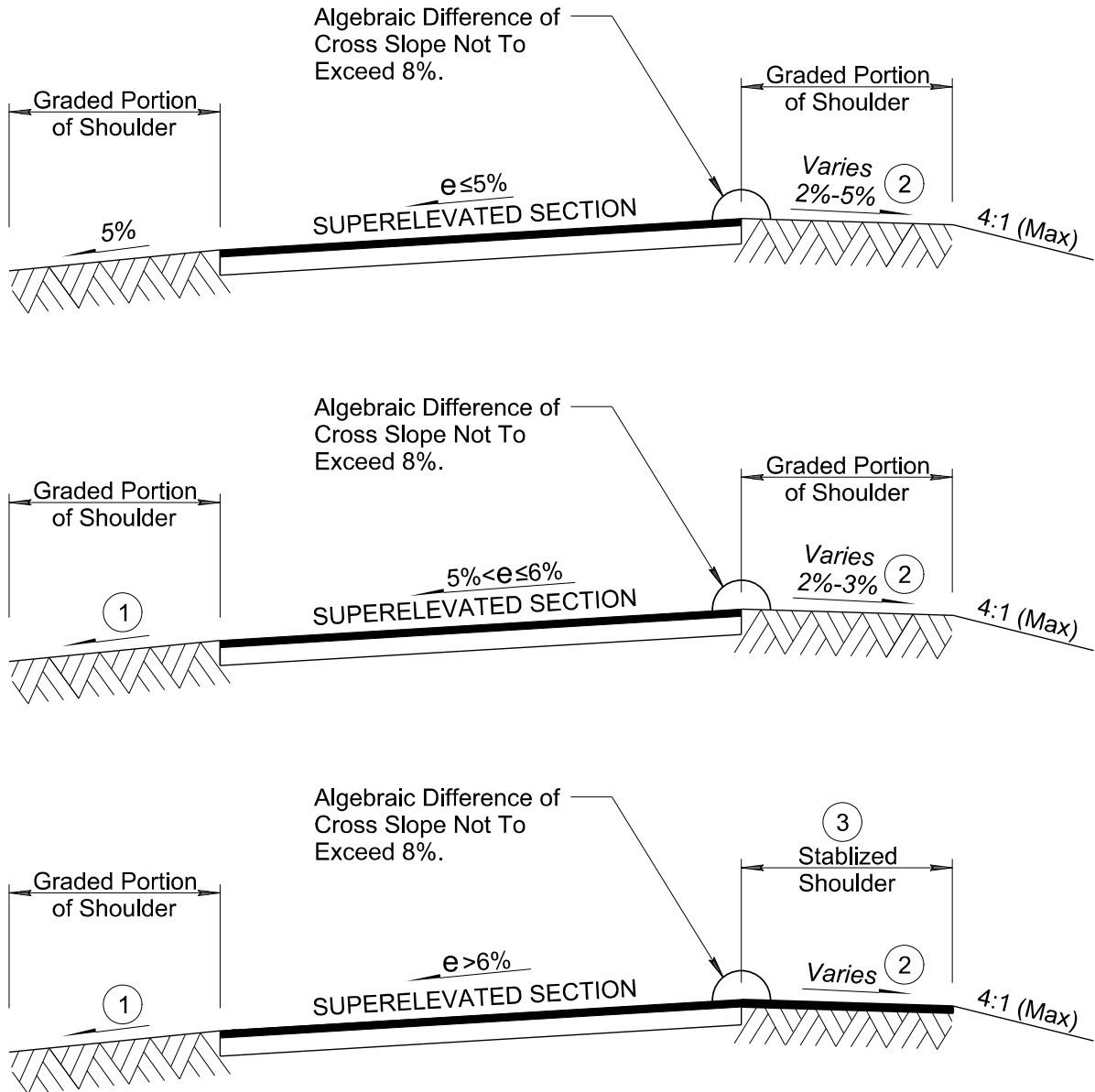


- ① Type A Vertical Curb and Gutter or Type B Ribbon Curb, MAG Standard Detail 220.
- ② Pavement Section to be determined by Geotechnical/Pavements Engineer in accordance with Chapter 10 (MCDOT Pavement Design Guide). Minimum pavement structural number (SN) ≥ 2.88.
- ③ Detached Sidewalk, MAG Standard Detail 230. Omit Sidewalk when Ribbon Curb is used.
- ④ Use 8' Sidewalk set back with 80' Right of Way.

FIGURE 5.14 - INDUSTRIAL/COMMERCIAL SUBDIVISION ROADS

MARICOPA COUNTY DEPARTMENT OF TRANSPORTATION  
STANDARD TYPICAL SECTION

ROADWAYS FOR  
INDUSTRIAL / COMMERCIAL SUBDIVISIONS



- ① Match Pavement Slope.
- ② Cross Slope of Graded Shoulder Can Vary in Superelevated Sections to Maintain 8% Maximum "Roll-Over" Cross Slope Difference.
- ③ Bituminous Stabilization or Asphalt Concrete Surface Required For Slopes < 2%.

**FIGURE 5.15 - SUPERELEVATED CROSS SECTIONS**

## **5.5 DESIGN SPEEDS**

### **Originator: Engineering and Transportation Systems Management & Operations Divisions**

The design of geometric features such as horizontal and vertical curves will depend upon the design speed selected for the street. The choice of the design speed is primarily determined by the street classification. The design speed is the maximum recommended speed at which reasonable safe operation of a vehicle can be maintained over a specific section of a road when conditions are so favorable that the design features of the road govern. Design speeds for the various classifications of roads are found in Table 5.2 for rural conditions and Table 5.3 for urban conditions. The use of design speeds other than those shown on these two tables must be approved by the MCDOT Director or an authorized representative.

It is important to remember that design speeds are 5-10 mph over anticipated posted operation speeds. Local roads designed using the minimum design speed may have a posted speed equal to the design speed.

<b>Classification</b>	<b>Terrain</b>	<b>Design Speed (mph)</b>
Rural Parkway	Level	65
	Rolling	60
	Mountainous	55
Rural Principal Arterial	Level	65
	Rolling	60
	Mountainous	55
Rural Minor Arterial	Level	60
	Rolling	55
	Mountainous	45
Rural Major Collector	Level	50
	Rolling	45
	Mountainous	40
Rural Minor Collector	Level	45
	Rolling	40
	Mountainous	35
Rural Local		35 Desirable 25 Minimum

Local roads located in level terrain shall use a design speed of 35 mph. In rolling and mountainous terrain a reduction in the design speed will be acceptable when the terrain makes the horizontal and/or vertical geometric alignment impractical at the 35 mph design speed. When natural slopes consistently rise and fall with grades above 4.0% a reduction of the design speed to 30 mph is acceptable. When natural slopes consistently rise and fall with grades above 8.0% a reduction of the design speed to 25 mph is acceptable.

<b>TABLE 5.3: MINIMUM DESIGN SPEEDS FOR URBAN ROADWAYS BY CLASSIFICATION AND TYPE OF TERRAIN</b>		
<b>Classification</b>	<b>Terrain</b>	<b>Design Speed (mph)</b>
Urban Parkway	Level	55
	Rolling	50
	Mountainous	45
Urban Principal Arterial	Level	55
	Rolling	50
	Mountainous	45
Urban Minor Arterial	Level	55
	Rolling	50
	Mountainous	45
Urban Major Collector	Level	40
	Rolling	30
	Mountainous	25
Urban Minor Collector	Level	40
	Rolling	30
	Mountainous	25
Urban Local		35 Desirable 25 Minimum
Frontage Road (Residential)		35 Desirable 25 Minimum

Local roads in residential subdivisions may use a design speed of 30 mph. A reduction in the design speed to 25 mph is acceptable in mountainous terrain where natural slopes consistently rise and fall with grades above 8.0%.

## **5.10 HORIZONTAL CURVES**

### **Originator: Engineering Division**

#### **5.10.1 GENERAL CONTROLS**

Flat curves should be provided wherever possible with the use of the minimum radius of curvatures restricted to, the most critical conditions. Alignment must be consistent. Sudden changes from flat to sharp curves and long tangents followed by sharp curves shall not be used because they create safety hazards. Likewise, reverse curves should be avoided because they inhibit some drivers from making passing maneuvers even when adequate sight distance exists.

The horizontal alignment development process can possibly introduce trial alignments which have curvature, superelevation, or superelevation transition carried onto or through a structure. Such alignments should be avoided, except when there is a definite need or a specific purpose. These situations almost always result in unsightly appearances of the bridge or bridge railing and create needless complications in design and construction. Safety considerations are paramount, however, and shall not be sacrificed to meet the foregoing criteria. Special authorization must be obtained from the MCDOT Director or an authorized representative when exceptions to the foregoing are desired.

A horizontal curve should not be introduced at or near the crest or sag of a vertical curve. This condition is hazardous because drivers cannot see the change in horizontal alignment, especially at night. The hazard can be avoided by having the horizontal curvature lead the vertical curvature, i.e.: the horizontal curve is made longer than the vertical curve.

For small deflection angles, curves should be sufficiently long to avoid the appearance of a kink. Curves should be at least 500 feet long for a central angle of 5 degrees or 10 times design speed whichever is less. The minimum length should be increased 100 feet for each degree decrease in the central angle.

Only tangent or flat curvatures should be used on high, long fills. In the absence of cut slopes, shrubs, and trees above the roadway, it is difficult for drivers to perceive the extent of curvature and adjust operation of their vehicles to the conditions. Further, any vehicle out of control on a high fill is in an extremely hazardous position. Adequately designed barriers, maintained to a high level of visibility and strength, are necessary to alleviate such a danger.

Caution should be exercised in the use of compound circular curves. Preferably, their use should be avoided where curves are sharp. Where topography or right-of-way, restrictions make their use necessary, the radius of the flatter circular arc should not be more than 50 percent greater than the radius of the sharper circular arc.

Any abrupt reversal in alignment 'S-curves' should be avoided. Such a change makes it difficult for drivers to keep within their own lanes. A reversal in alignment can be designed suitably by including a sufficient length of tangent between the two to effect superelevation transition.

The 'broken-back' or 'flat-back' arrangement of curves (having a short tangent between two curves in the same direction) should be avoided.

The horizontal alignment should be coordinated carefully with the profile design to avoid the appearance of inconsistent distortion.

**5.10.2 SUPERELEVATION RATES**

The use of superelevation will depend on the classification of the roadway being designed. Before proceeding with the design, the Design Engineer should be sure to establish the correct roadway classification with MCDOT at the beginning of the design project.

For MCDOT local residential streets with design speeds at or less than 35 mph, no superelevation is to be incorporated in the roadway design. The normal two-way crown section (-0.02 ft per ft) will be used. The minimum radius of curvature for given design speeds is shown on Table 5.4.

<b>TABLE 5.4: MINIMUM RADII FOR LOCAL RESIDENTIAL STREETS</b>			
<b>Design Speed (mph)</b>	<b>Max. e</b>	<b>Max. f</b>	<b>Min. R (ft.)</b>
25	-0.02	0.23	200
30	-0.02	0.20	335
35	-0.02	0.18	510

On all other roadways in Maricopa County, the superelevation rate and radius of curvature will be designed together as a function of the value for maximum side friction and the assumed maximum allowable superelevation rate  $e_{max}$ .

For rural roadway design,  $e_{max}$  is not to exceed 0.08.

For all urban roadway sections,  $e_{max}$  shall be 0.04.

For detour roadways requiring superelevation  $e_{max}$  will be 0.04.

Use the appropriate  $e_{max}$  table in the AASHTO publication ‘A Policy on Geometric Design of Highways and Streets’ for the design superelevation rate and design speed.

The radius used to design superelevation for horizontal curves is the inside edge of the innermost travel lane.

The Design Engineer should always strive to implement the largest radius of curvature possible for the given design constraints.

The allowable radius for roadway curves is a function of velocity, superelevation, and side friction. The minimum radii for curves shall be based on the following formula.

$$R_{min} = \frac{V^2}{15(0.01e_{max} + f_{max})}$$

Where

- V = Design Speed (mph)
- e = Superelevation rate (percent)
- f = Side Friction Factor
- R = Curve Radius (feet)

Values for the side friction factors to be used for design shall be as recommended in the AASHTO publication ‘A Policy on Geometric Design of Highways and Streets’ (for the 2011 6<sup>th</sup> edition see Figure 3-6 or Table 3-7).

### 5.10.3 INTERSECTION CURVES

Minimum radii for curves at intersections shall be based on superelevation, design turning speed, and side friction factors. The side friction factors for various speeds shall not exceeding those shown in Table 5.5. The minimum radius applies to the inside edge of the innermost travel lane. Table 5.5 provides a sampling of superelevation rates, the minimum curve radius will depend on the superelevation rate of the actual intersection curve being designed.

Design (turning) speed, V (mph)	10	15	20	25	30	35	40
(Assumed average running speed - mph)	10	14	18	22	26	30	34
Side friction factor, f	0.38	0.32	0.27	0.23	0.20	0.18	0.16
Assumed minimum superelevation, e	-0.02	0.00	0.00	0.02	0.02	0.04	0.04
Total e + f	0.36	0.32	0.27	0.25	0.22	0.22	0.20
Calculated minimum radius, R (ft)	19	47	99	167	273	371	485
Suggested curvature for – design:							
Suggested Design Radius (minimum ft)	25	50	100	170	275	375	485

NOTE: For design speeds of more than 40 mph, use values for open highway conditions.

### 5.10.4 SUPERELEVATION TRANSITION

Superelevation runoff is the general term denoting the length of highway needed to accomplish the change in cross slope from a section with adverse crown removed to a fully superelevated section, or vice versa. Tangent runout is the general term denoting the length of highway needed to accomplish the change in cross slope from a normal crown section to a section with the adverse crown removed, or vice versa. For added comfort and safety, the superelevation runoff should be established uniformly over a length adequate for the likely operating speeds. To be pleasing in appearance, the runoff pavement edges should not be distorted as the driver views them.

The length of tangent runout is determined by the amount of adverse crown to be removed and the rate at which it is removed. The rate of removal should be the same as the rate used to effect the superelevation runoff.

The minimum superelevation runoff length is determined from the rotated pavement width and the relative gradient between the profile along the axis of rotation and the outermost pavement edge. The difference in longitudinal gradients varies with the design speed. The maximum relative gradients between the profiles for rotating a twelve foot pavement width is given in Table 5.6.

<b>TABLE 5.6: DESIGN SPEED AND RELATIVE PROFILE GRADIENTS</b> (For Superelevation of 12' Wide Pavements <u>OR</u> Rotation of 12' Wide Pavements)		
<b>Design Speed (mph)</b>	<b>Maximum Relative Gradients (%)</b>	<b>Equivalent Maximum Relative Slope</b>
25	0.73	1:137
30	0.67	1:150
35	0.62	1:161
40	0.57	1:175
45	0.54	1:185
50 and greater	0.50	1:200

Curves are preferably designed with 60 to 80 percent of the superelevation runoff length located on the tangent section adjacent to the curve. Superelevation is usually attained by revolving a crowned pavement about the centerline profile. Where drainage is a major control, superelevation may be attained by revolving the pavement about an edge.

In the design of divided highways, roads, and parkways, the inclusion of a median in the cross section will influence the superelevation runoff design. For medians 8 feet or less in width, the whole of the traveled way, including the median, is often superelevated as a plane section. Superelevation runoff lengths for these divided roads should be increased in proportion to the total width, including the median. For medians 8 feet or more in width, the median is often held in a horizontal plane and the two pavements separately are rotated around the median edges or, where applicable, around the inside gutter lines.

The superelevation runoff length for rotation of pavement widths greater than twelve feet is increased and the increase is a function based on the runoff length of a single 12 foot lane.

$$n_1 b_w = \frac{1}{2} \left[ \frac{x}{12} + 1 \right] \quad \text{Equation 5.10.3}$$

Where

- $n_1 b_w$  = Superelevation length increase relative to one rotated 12-foot lane
- $x$  = Rotated pavement width

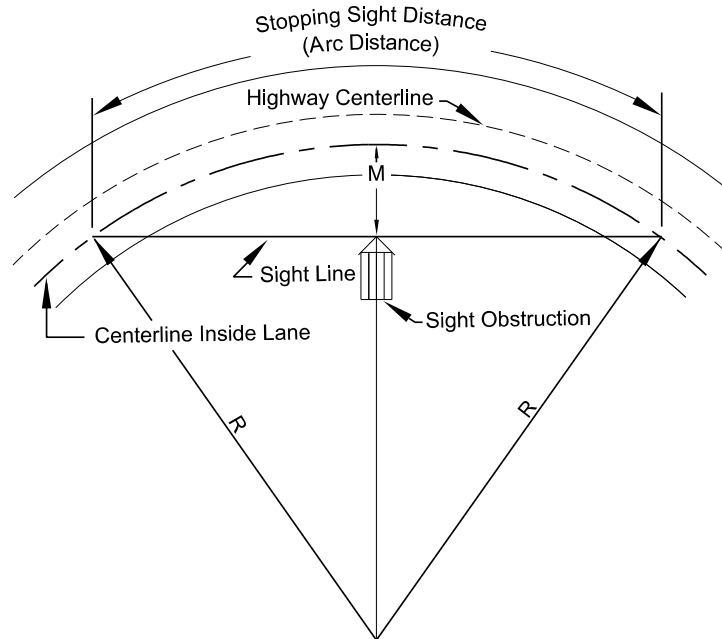
Superelevation runoff lengths for horizontal curves of various  $e_{max}$  values are available in the AASHTO publication 'A Policy on Geometric Design of Highways and Streets'. The AASHTO indicated values for runoff lengths should be considered minimums values. Pavement-edge profiles should be smooth-flowing without abrupt changes.

### 5.10.5 SIGHT DISTANCE ON HORIZONTAL CURVES

Objects such as walls, cut slopes, buildings, guardrail, and vegetation located on the inside of a curve may cause sight obstructions that will require adjustment of the horizontal alignment if they cannot be removed. The Design Engineer is to check for sight obstructions and make adjustments

as needed to provide adequate sight distance. The assumed criteria used for stopping sight distance is an eye height 3.50 feet and a 2.0 foot object height.

The stopping sight distance is measured along the centerline of the lane being checked for sight obstructions. For horizontal curves the stopping sight distance is measured along the centerline of the inside lane of the curve; the sight line is a straight line connecting the beginning and end points of the stopping sight distance (see Figure 5.16). For grades exceeding 2% the stopping sight distance shall be grade adjusted (see Table 5.12) and the stopping sight distance is to be obtained along both the inside lane around the curve and the inside lane in the down hill direction.



**FIGURE 5.16 – HORIZONTAL SIGHT LINE OFFSET**

For horizontal curves with a length greater than the stopping sight distance, equation 5.10.4 gives the sight line offset distance from the centerline of the inside lane.

$$M = R \left[ 1 - \cos \left( \frac{90 S}{\pi R} \right) \right] \quad \text{Equation 5.10.4}$$

Where

$M$  = Middle Ordinate – The horizontal offset distance between the lane centerline and the midpoint of the sight line (ft).

$R$  = Centerline radius of the inside travel lane (ft).

$S$  = Grade adjusted stopping sight distance (ft).

## **5.11 VERTICAL ALIGNMENT**

### **Originator: Engineering Division**

#### **5.11.1 VERTICAL CURVES**

Vertical-curves shall be designed to provide adequate sight distance, safety, comfortable driving, good drainage, and a pleasant appearance. Algebraic difference in grades without a vertical curve on continuous roadways shall be equal to or less than the values specified for the following conditions:

- ◇ 0.2% Federal Aid Projects (applies to National Highway System roads)
- ◇ 0.3% Equal to or greater than 55 mph design speed
- ◇ 0.5% Equal to or greater than, 40 mph, but less than 55 mph design speed
- ◇ 1.0% Less than 40 mph design speed
- ◇ 2.0% Local residential street

Minimum or greater stopping sight distances should be provided in all cases. The Design Engineer must exercise considerable judgment in designing vertical curves because lengths in excess of the minimum may be needed at driver, decision points, either where drainage or aesthetic problems exist or simply to provide an additional margin of safety. A long curve has a more pleasant appearance than a short one; short curves may cause the appearance of a sudden break in the profile due to the effect of foreshortening. They should normally be symmetrical parabolas with the minimum length in feet equal to 3 times the design speed in miles per hour. Two lane rural roadways should consider the need for longer vertical curves to accommodate passing sight distance requirements.

#### **5.11.2 GRADES**

Grade length and steepness directly affect the operational characteristics of the road. When vertical curves are considered for stopping sight distances, there seldom are advantages to using the maximum grade values except when grades are long. Grades below the maximum are always desirable. The minimum grades ( $\pm 0.25\%$  desirable, or  $\pm 0.15\%$  in special cases) are considered primarily to provide natural roadside drainage. These minimum grades should never be used in conjunction with minimum cross slopes. Maximum grades for the various classifications of roads may be found in Table 5.7. Maximum grades shown for rural and urban collectors of short lengths (less than 500 ft) and on one-way down grades may be one percent steeper. See Table 5.10, Chapter 5, Section 15, for the effects of grades on stopping sight distances.

<b>TABLE 5.7: MAXIMUM VERTICAL GRADES (%)</b>						
<b>LOCAL ROADS – DESIGN SPEED (mph)</b>						
<b>Terrain</b>	<b>25</b>	<b>30</b>	<b>35</b>	<b>40</b>	<b>50</b>	<b>60</b>
Level	7	7	7	7	6	5
Rolling	11	10	10	10	8	6
Mountainous	15*	14	13	13	10	---
<b>RURAL COLLECTOR ROADS** - DESIGN SPEED (mph)</b>						
<b>Terrain</b>	<b>35</b>	<b>40</b>	<b>45</b>	<b>50</b>	<b>55</b>	<b>60</b>
Level	---	---	7	6	6	5
Rolling	---	8	8	7	7	6
Mountainous	10	10	10	9	9	8
<b>URBAN COLLECTOR ROADS** - DESIGN SPEED (mph)</b>						
<b>Terrain</b>	<b>25</b>	<b>30</b>	<b>35</b>	<b>40</b>	<b>45</b>	<b>50</b>
Level	---	---	---	9	8	7
Rolling	---	11	10	10	9	8
Mountainous	13	12	12	12	11	10
<b>RURAL ARTERIAL ROADS – DESIGN SPEED (mph)</b>						
<b>Terrain</b>	<b>45</b>	<b>50</b>	<b>55</b>	<b>60</b>	<b>65</b>	<b>70</b>
Level	-	-	-	3	3	3
Rolling	-	-	5	4	4	4
Mountainous	7	7	6	6	5	5
<b>URBAN ARTERIAL ROADS – DESIGN SPEED (mph)</b>						
<b>Terrain</b>	<b>35</b>	<b>40</b>	<b>45</b>	<b>50</b>	<b>55</b>	<b>60</b>
Level	---	---	-	6	5	5
Rolling	---	---	-	7	6	6
Mountainous	---	---	9	9	8	8
* Designs with grades exceeding 15% for a distance not exceeding 500 feet with a grade not exceeding 18% will require approval of the local fire district in addition to a design exception						
** Maximum grades shown for rural and urban conditions of short lengths (less than 500 ft) may be 1% steeper on one-way down grades.						

### 5.11.3 CREST VERTICAL CURVES

Minimum lengths of crest vertical curves as determined by sight distance requirements generally are satisfactory from the standpoint of safety, comfort, and appearance. An exception may be at

decision areas, where longer lengths are necessary. The basic formulas for length of a parabolic vertical curve in terms of algebraic difference in grade and sight distance is as follows

When S is less than L

$$L = \frac{AS^2}{100(\sqrt{2h_1} + \sqrt{2h_2})^2}$$

When S is greater than L

$$L = 2S - \frac{200(\sqrt{h_1} + \sqrt{h_2})^2}{A}$$

Where:

$L$  = length of vertical curve, ft

$A$  = algebraic difference in grades, percent

$S$  = sight distance, ft

$h_1$  = height of eye above roadway surface, ft

$h_2$  = height of object above roadway surface, ft

the assumed height of eye and height of object shall be 3.5 feet and 2.0 feet, respectively.

<b>TABLE 5.8: SIGHT DISTANCE DESIGN PARAMETERS FOR CREST VERTICAL CURVES</b>	
Height of eye ( $h_1$ )	$h_1 = 3.5'$
Height of object ( $h_2$ )	$h_2 = 2.0'$
When S is less than L	$L = AS^2 / 2,158$
When S is greater than L	$L = (2S) - (2,158 / A)$

Once the curve lengths have been established for design speeds, the term K is computed, which is  $L/A$ . This permits determining the minimum curve length by the equation:  $L = KA$ , where S is less than L. The selection of design curves is facilitated because the required length of the curve in feet is equal to K times the algebraic difference in grades in percent,  $L = KA$ . Table 5.9 provides design K values for various design speeds for crest vertical curves based on stopping sight distance.

The above values of K that are derived when S is less than L can also be used without significant error where S is greater than L. As a practical minimum, the length of the vertical curve is equal in feet to 3 times the design speed in miles per hour.

There is a level point on crest vertical curves. Special attention is needed in these cases to ensure proper pavement drainage near the apex of crest vertical curves. For K values greater than 167, drainage must be carefully designed.

<b>TABLE 5.9: DESIGN CONTROLS FOR CREST VERTICAL CURVES</b>			
Design Speed (mph)	Stopping sight distance on level terrain (ft)	Rate of vertical curvature, K <sup>a</sup>	
		Calculated	Design
25	155	11.1	12
30	200	18.5	19
35	250	29.0	29
40	305	43.1	44
45	360	60.1	61
50	425	83.7	84
55	495	113.5	114
60	570	150.6	151
65	645	192.8	193

<sup>a</sup> Rate of vertical curvature, K, is the length of curve per percent algebraic difference in intersecting grades (A).  $K=L/A$

**5.11.4 PASSING SIGHT DISTANCE ON CREST VERTICAL CURVES**

Design values of crest vertical curves for passing sight distance differ from those for stopping sight distance because of the different height criterion. The 3.5 feet height of objects results in the following specific formulas with the same terms as above:

When S is less than L,  $L = AS^2 / 2,800$

When S is greater than L,  $L = (2S) - (2,800 / A)$

For minimum passing sight distances, the required lengths of crest vertical curves are substantially longer than those for stopping sight distances. Generally, it is not practical to design crest vertical curves to provide for passing sight distance because of high costs where crest cuts are involved and the difficulty of fitting the required long vertical curves to the terrain, particularly for high speed roads. Passing sight distance on crest vertical curves may be feasible, and should be incorporated when practicable, on roads with an unusual combination of low design speed and gentle grades or, higher design speeds with very small algebraic differences in grades.

**5.11.5 SAG VERTICAL CURVES**

When a vehicle traverses a sag vertical curve at night, the portion of highway lighted ahead is dependent on both the position of the headlights, and the direction of the light beam. Assumed design values are a headlight height of 2 feet and a 1 degree upward divergence of the light beam from the longitudinal axis of the vehicle. For overall safety, the light beam distance is nearly the same as the stopping sight distance. Accordingly, it is pertinent to use stopping sight distances for the different design speeds. Basic formulas for the length of a sag vertical curve are:

When S is less than L,  $L = AS^2 / (400 + 3.5 S)$

When S is greater than L,  $L = (2S) - (400 + 3.5S) / A$

where:

L = length of sag vertical curve, in feet

S = light beam distance, in feet – (stopping sight distance for headlight control).

A = algebraic difference in grades, percent

There is a level point on sag vertical curves. Special attention is needed in these cases to ensure proper pavement drainage near this point on sag vertical curves.

Once the curve lengths have been established for design speeds, the term K is computed which is L/A. This permits determining the minimum curve length by the equation:  $L = KA$ , where S is less than L. The selection of design curves is facilitated because the required length of the curve in feet is equal to K times the algebraic difference in grades in percent,  $L = KA$ . Table 5.10 provides design K values for various design speeds for Sag vertical curves based on headlight control.

The Design Engineer should consider the general appearance of vertical curves, especially for small or intermediate values of A. Minimum lengths of sag vertical curves are equal to 3 times the design speed, except for rural arterials which shall have a minimum length of 800 feet.

<b>TABLE 5.10: DESIGN CONTROLS FOR SAG VERTICAL CURVES</b>			
Design Speed (mph)	Stopping sight distance on level terrain (ft)	Rate of vertical curvature, K <sup>a</sup>	
		Calculated	Design
25	155	25.5	26
30	200	36.4	37
35	250	49.0	49
40	305	63.4	64
45	360	78.1	79
50	425	95.7	96
55	495	114.9	115
60	570	135.7	136
65	645	156.5	157

<sup>a</sup> Rate of vertical curvature, K, is the length of curve per percent algebraic difference in intersecting grades (A).  $K=L/A$

### 5.11.6 GENERAL CONTROLS

In addition to the above specific control for vertical alignment, there are several general controls that should be considered in design:

1. A smooth gradeline with gradual changes, as consistent with the type of road and the character of the terrain, is preferable to a line with numerous breaks and short lengths of grades. Detailed

design values are the maximum grade and the critical length of grade; however, the manner in which they are applied and fitted to the terrain on a continuous line determines the suitability and appearance of the finished product.

2. The 'Roller-Coaster' or the 'hidden-dip' type of profile shall be avoided.
3. Undulating gradelines, involving substantial lengths of momentum grades, should be appraised for their effect on traffic operation.
4. A broken-back gradeline (two vertical curves in the same direction separated by short sections of tangent grade) shall be avoided.
5. On long grades it may be preferable to place the steepest grades at the bottom and lighten the grades near the top of the ascent or to break the sustained grade by short intervals of lighter grade instead of a uniform sustained grade that might be only slightly below the allowable maximum. This is particularly applicable to low-design-speed roads and streets.
6. Where intersections at grade occur on roadway sections with moderate to steep grades, it is desirable to reduce the gradient through the intersection. Such a profile change helps all vehicles making turns and serves to reduce potential hazards. See intersection general controls in Section 1 of Chapter 6.

## **5.12 HIGHWAY ALIGNMENT**

### **Originator: Engineering Division**

#### **COMBINATION OF HORIZONTAL AND VERTICAL ALIGNMENT**

The proper combination of horizontal and vertical alignments is obtained after an engineering study and consideration of the following general controls:

1. A vertical curvature superimposed on a horizontal curvature generally results in a more pleasing facility, but the resultant effect on traffic must also be analyzed.
2. A sharp horizontal curvature should not be introduced at or near the top of a pronounced crest vertical curve.
3. A sharp horizontal curvature should not be introduced at or near the low point of a pronounced sag vertical curve.
4. The horizontal curvature and profile should be made as flat as feasible at intersections where sight distance along roads is important and vehicles may have to slow or stop.
5. Avoid a short tangent section on a crest vertical curve between two horizontal curves.

## **5.15 STOPPING SIGHT DISTANCES**

### **Originator: Engineering and Transportation Systems Management & Operations Divisions**

The height criteria used for the stopping sight distance is based on an assumed driver's eye height of 3.5 feet and an object height of 2.0 feet.

For the passing sight distance, the height criteria is the same 3.5 feet high driver's eye height and an oncoming vehicle 3.5 feet high.

The minimum stopping and passing sight distances for nearly level roadways shall vary with the design speeds as indicate in Table 5.11.

<b>TABLE 5.11: PASSING AND STOPPING SIGHT DISTANCES</b>		
<b>Design Speed (mph)</b>	<b>Stopping Sight Distance (feet)</b>	<b>Passing Sight Distance (feet)</b>
25	155	450
30	200	500
35	250	550
40	305	600
45	360	700
50	425	800
55	495	900
60	570	1,000
65	645	1,100

For grades that exceed 2%, the stopping sight distance provided is to be at least equal to the values shown in Table 5.12. Values may be interpolated as necessary.

<b>TABLE 5.12: GRADE ADJUSTED STOPPING SIGHT DISTANCES</b>								
<b>Design Speed (mph)</b>	<b>Stopping Sight Distance (feet) Downgrades</b>				<b>Stopping Sight Distance (feet) Upgrades</b>			
	<b>3%</b>	<b>6%</b>	<b>9%</b>	<b>12%</b>	<b>3%</b>	<b>6%</b>	<b>9%</b>	<b>12%</b>
25	158	165	173	184	147	143	140	137
30	205	215	227	242	200	184	179	175
35	257	271	287	308	237	229	222	216
40	315	333	354	381	289	278	269	261
45	378	400	427	462	344	331	320	310
50	446	474	507		405	388	375	
55	520	553	593		469	450	433	
60	598	638	686		538	515	495	
65	682	728	785		612	584	561	

## **5.20 TRANSITION TAPERS**

### **Originator: Engineering and Transportation Systems Management & Operations Divisions**

#### **5.20.1 NARROWING TRANSITIONS**

When a proposed roadway will directly connect with an existing roadway of a smaller width, it is necessary to install a transition taper between the two. Taper lengths on roads with a design speed less than or equal to 40 mph shall be:

$$L=WS^2/ 60$$

Where the design speed is greater than 40 mph:

$$L=WS$$

Where:

W = Offset from drivable through lane in feet

S =Design speed

L =Taper length

#### **5.20.2 WIDENING TRANSITIONS**

When transitioning from a narrow section to a wide section use an opening taper rate of 8:1 [L:W] minimum and 15:1 [L:W] maximum. Use an 8:1 [L:W] opening taper for design speeds of 30 mph or less and for design speeds of 50 mph or greater use a 15:1 [L:W] taper.

#### **5.20.3 TRANSITION GEOMETRICS**

Straight line tapers are to be used for uncurbed roadways. Reverse curves are to be used for curbed roadways.

## **5.25 CLEAR ZONES**

### **Originator: Engineering and Transportation Systems Management & Operations Divisions**

#### **5.25.1 GENERAL CRITERIA**

The clear zone is the lateral distance from the edge of the traveled way that is available for the safe use of errant vehicles. To protect clear zone integrity, the clear zone recovery area shall be within right-of-way. Rigid obstacles and certain other features within the recommended minimum clear zone recovery area shall be adjusted so that:

- ◇ Obstacles which may be removed should be eliminated.
- ◇ Obstacles which may not be removed should be relocated laterally or to a more protected location.
- ◇ Obstacles which may not be moved should be reduced in impact severity. Breakaway devices and flattened side slopes offer such an improvement.
- ◇ Obstacles which may not be otherwise treated should be shielded by crash-worthy devices such as guardrail.

#### **5.25.2 OBSTACLES**

Obstacles and features which need to be analyzed include such items as:

- ◇ Rough rock cuts
- ◇ Boulders over 2 feet in diameter
- ◇ Riprap over 4 inches in diameter
- ◇ Streams or permanent bodies of water more than 2 feet deep
- ◇ Signs, traffic signals, and luminaire supports with a breakaway or yielding design with linear impulses greater than 1,100 lb-sec
- ◇ Signs, traffic signals, and luminaire supports with a concrete base extending 6 inches or more above ground
- ◇ Bridge piers and abutments
- ◇ Retaining walls and culverts
- ◇ Trees with an expected mature size greater than 4 inches in diameter
- ◇ Wood poles or posts with a cross sectional area greater than 16 square inches
- ◇ Culverts, pipes, and headwalls
- ◇ Embankments
- ◇ Fire hydrants
- ◇ Benches that are fixed to the ground
- ◇ Non-Standard mailboxes

Above ground facilities of utility companies should be located outside of the clear zone and as near to the right-of-way as practical.

### 5.25.3 EMBANKMENTS

The design slope used for roadway embankments depends upon the existing terrain, available right-of-way, safety considerations, and economics. Embankments shall have a minimum slope of 20:1 (5% grade) for drainage.

1. Embankment slopes that minimize clear zone distances for errant vehicle recovery are slopes of 6:1 (Horz:Vert) or flatter. This condition can often be met in level terrain and is the basis for the minimum right-of-way widths shown for rural typical sections on Figure 5.1 through Figure 5.6.
2. Embankment slopes with slopes greater than 6:1 but not exceeding 4:1 (Horz:Vert) are deemed recoverable slopes and require a larger clear zone recovery area. This slope range may require more than the minimum right-of-way shown for rural typical sections.
3. Embankment slopes that exceed 4:1 but do not exceed 3:1 (Horz:Vert) are classified as traverseable not recoverable. These slopes are not included in the clear zone recovery area. The use of traverseable non-recoverable slopes and the larger associated right-of-way width versus steeper slopes and a protective barrier depends on an evaluation of the safety and the economics of the various potential alternatives.
4. Slopes that exceed 3:1 (Horz:Vert) are considered non-traversable and require a protective barrier to prevent vehicle access. This condition is often found in mountainous terrain or when available right-of-way is restricted. Embankment slopes of 3:1 (Horz:Vert) or steeper shall provide an accessible slope maintenance area at least ten feet wide at the bottom of the slope. The cross slope for the slope maintenance area shall not exceed 10:1 (Horz:Vert). Slope maintenance areas shall be contained within right-of-way.

Roadway embankment slopes shall be contained within right-of-way.

### 5.25.4 CLEAR ZONE WIDTH

#### 5.25.4.1 Rural Conditions

1. Local roads shall have a minimum clear zone width of 10 feet.
2. Collector roads, with a design speed of 40 mph and below, shall have a minimum clear zone width of 10 feet.
3. Parkways, arterial roads, and collector roads with a design speed greater than 40 mph shall have as a minimum the clear zone as recommended in the AASHTO Roadside Design Guide. The AASHTO suggested clear zone distances may be limited to 30' prior to the application of the horizontal curve adjustment factor. The clear zone width for parkways, arterial roads, and major collector roads shall be based on a design ADT of over 6000. Where the embankment slope changes along the roadway, the clear zone width will change proportionally. The clear zone widths on the outside of horizontal curves shall be increased in accordance with the horizontal curve adjustment factors contained in the AASHTO Roadside Design Guide.

#### 5.25.4.2 Urban Conditions

The clear zone width for rural conditions shall be maintained for urban conditions when practicable. The application of these urban conditions assume lower operating speeds than rural conditions and require longitudinal curb lines to be located in conformance with the typical urban roadway cross sections (Figure 5.7 – Figure 5.14) for the roadway's designated classification.

For urban roadways where a six-foot (6') bicycle lane is provided, a clear zone width of four-feet (4') shall be provided behind the face of curb that is free of all obstacles. For urban roadways without a bicycle lane, a six foot width clear zone shall be provided behind the face of curb that is free of all obstacles.

At signalized intersections where curb returns are provided signal poles should be placed a minimum six-foot (6') behind the face of curb.

If the required six-foot (6') width is found impractical a reduction of the clear zone to four-feet (4') is acceptable with approval from MCDOT Engineering Division. The Design Engineer should prepare a design memo detailing the request.

#### **5.25.4.3 Sidewalks and Pathways**

A lateral two foot clear distance shall be maintained between above ground obstacles and adjacent sidewalks and pathways, unless otherwise approved by MCDOT.

#### **5.25.5 VERTICAL CLEARANCE**

All roadways shall maintain a minimum vertical clearance of 16-feet over the entire roadway width.

## **5.30 GUARDRAIL**

### **Originator: Engineering and Transportation Systems Management & Operations Divisions**

#### **5.30.1 PURPOSE**

The primary purpose of a guardrail is to safely redirect an errant vehicle away from a roadside object or feature.

#### **5.30.2 TYPE**

Guardrail and bridge concrete barrier transitions shall be constructed per MAG Uniform Standard Specifications and Details as modified by the MCDOT Supplement to the MAG Uniform Standard Specifications and Details.

The use of special coatings on any guardrail component or the use of weathering steel requires specific approval from the Maricopa County Department of Transportation.

The type of treatment to mitigate roadside hazards shall take into consideration the cost to remove or reduce the hazard so that shielding is unnecessary compared with the cost of maintenance and installation of a barrier.

#### **5.30.3 PLACEMENT**

The guardrail should be set as far as practical from the edge of the traffic lanes.

The face of guardrail is usually installed along the edge of pavement alignment with the face of rail set not less than 2 feet from the edge of the driving lane.

The structural pavement section shall be extended to the face of rail with asphalt surfacing extending two feet beyond the back of post.

The face of the guardrail should be a minimum of 4.0 feet in front of any shielded object but when this distance is unattainable, stiffening of the guardrail shall be considered.

In fill sections, the back of the guardrail post shall be a minimum of 2 feet in front of the hinge point of the slope to ensure adequate lateral soil resistance for the posts during impact.

If a curb must be used with a guardrail, the face of the curb shall be behind or flush with the face of the guardrail. Vertical curbs higher than 4" shall not be used with guardrail.

#### **5.30.4 END TREATMENTS**

Ends of longitudinal barrier within the clear zone shall have crash worthy end treatments. Grading

and paving limits for End Terminal layouts treatments shall be shown to scale on the plans per manufactures placement guidelines in accordance with MCDOT Standard Details.

### **5.30.5 BARRIER TRANSITIONS**

Transition sections are necessary to provide continuity of protection when two different roadside barrier systems join, when roadside barriers join another barrier system (i.e., bridge rail), or when a roadside barrier is attached to or adjacent to a rigid object such as a bridge pier. Standard transition sections for attachment of guardrail to safety-shape barrier are shown in the Construction Standard Drawings.

### **5.30.6 EMBANKMENT/EXTRUDED CURB**

Extruded curb in conjunction with embankment spillways and down drains shall be installed under non-curbed guardrail sections based on drainage calculations to prevent erosion and degradation of roadway shoulders and embankments. Other slope erosion protection solutions may be considered if they are more appropriate.

### **5.30.7 LENGTH**

The length of need for guardrail shall be determined using procedures contained in AASHTO's "Roadside Design Guide, 2011." The length of need and its locations (the length of need point) shall be shown on the construction plans.

Proper protection for canal bridges approaches shall be provided. The Design Engineer shall coordinate with the water authority and obtain the water authority's approval for any solution involving realignment of the canal maintenance road or other canal facility.

## **5.35 PAVEMENT EDGE TREATMENTS**

### **Originator: Engineering Division**

The pavement edge for all asphalt roadways shall be protected by a safety edge, thickened edge, concrete curbing, or cutoff wall.

#### **5.35.1 SAFETY EDGE**

A safety edge shall be installed at the edge of asphalt pavement for all uncurbed roadways having a design speed of 40 mph or greater. The safety edge shall be installed at the edge of the asphalt pavement regardless of the distance between the pavement edge and the closest travel lane. When a roadway that requires a safety edge is overlaid, the overlay operation shall include installing a safety edge if none exists or overlaying an existing safety edge to produce a finished surface that complies with safety edge requirements.

#### **5.35.2 ASPHALT THICKENED EDGE**

An asphalt thickened edge shall be installed on all uncurbed roadways where a safety edge is not installed. Install an asphalt thickened edge:

- A. Along the edge of roadways having a design speed of less than 40 mph,
- B. At the termination of asphalt roadway pavement (requires MAG Detail 201, Type D),
- C. Edge of pavement behind guardrail.

#### **5.35.3 CURBS**

##### **Vertical Curbs**

Vertical curbs deter vehicle operators from driving onto areas not intended for vehicular use and helps to contain longitudinal street drainage. Vertical curbs shall only be used where the posted speed of the road is 45 mph or less.

Vertical curb and gutter shall be constructed in accordance with, MAG Standard Detail 220, Type A. The height in inches for dimension H shown in the Standard Detail is normally 6 inches.

Provide MAG Type E Mountable Curb & Gutter at maintenance or emergency access points where use by the public is not desired. Sidewalk located behind Type E Curb & Gutter is to use the concrete class and thickness as required for driveways.

##### **Roll Curbs**

Roll curb and roll curb and gutter shall be constructed in accordance with MAG Standard Detail 220.

##### **Ribbon Curbs**

Ribbon curbs shall be constructed in accordance with MAG Standard Detail 220, Type B.

### **5.35.4 CURB RETURNS**

The minimum radii for curb returns at street intersections shall be in accordance with Table 6.3.

Offsets for curb return radius points may be necessary to achieve throat widening required to accommodate the design vehicle turning path. An offset curb return may use a taper or large radius curve to transition to the standard curb location.

Curb returns shall be vertical curb, (four or six inches high) consistent with the height of adjacent connecting curb. The curb height within the curb return shall match the height of the adjacent connecting curb. Transitioning from different heights of curb may occur at curb ramps. Transitioning from different types of curb shall be done in curb transitions. The curb transition shall not extend into the curb return.

### **5.35.5 CUTOFF WALLS**

At ford locations where roads are dipped to allow drainage flows to cross the roadway, cutoff walls shall be used to protect from erosion.

For uncurbed roadways locate the cutoff walls at the normal edge of shoulder location and extend the pavement across the shoulders to the cutoff walls.

For curbed roadways cutoff walls may be incorporated into other standard elements. Cutoff walls can be combined with ribbon curb, attached sidewalk, concrete scupper spillway, or other element by modifying a standard detail.

## **5.36 SIDEWALKS**

### **Originator: Engineering Division**

#### **5.36.1 GENERAL**

Sidewalks shall be designed in accordance with the MAG Uniform Standard Specifications and Details for Public Works Construction as Supplemented by MCDOT. All newly constructed sidewalks shall comply with the accessible route requirements of the Americans with Disabilities Act (ADA).

Sidewalks shall be six feet (6') or greater in width unless approved by the MCDOT Engineering Division. If the required six foot (6') sidewalk width is found impracticable the Design Engineer shall submit an alternative sidewalk design proposal to the MCDOT Engineering Division for approval. Sidewalks shall be provided in all urban subdivisions.

Shared use paths shall be ten feet (10') or greater in width. Replacement of standard sidewalk with shared use paths will be evaluated on a case by cases basis.

For capital projects in rural areas, sidewalks will generally not be required. The need for sidewalks in developing urban areas will be evaluated on a case by case basis.

#### **5.36.2 DETECTABLE WARNINGS**

Detectable warnings are to be installed at locations that represent potential hazards for pedestrians with vision impairments such locations include walkways that cross roadways and railroad tracks.

Detectable warnings shall be installed perpendicular to the direction of pedestrian travel and have a minimum width of 24 inches measured perpendicular to the edge of the roadway or rail crossing.

Detectable warnings shall be installed on walkways at roadway crossings whenever the walking surface is not separated from the roadway by curbs, railings or other approved elements. Detectable warnings installed on curb ramps shall extend the full width of the ramp depression. The detectable warning surface shall be located so that the edge nearest the curb line is 6 inches minimum and 8 inches maximum back from the face of curb.

Detectable warning for pedestrian at-grade rail crossings not located within a street or highway shall be located on each side of the rail crossing so that the edge nearest the rail crossing is 6 inches minimum and 8 inches maximum from the vehicle dynamic envelope. The edge of the detectable warning surface nearest the rail crossing shall be 6.0 feet minimum and 15.0 feet maximum from the centerline of the nearest rail. Where pedestrian gates are provided, detectable warning surfaces shall be placed on the side of the gate opposite the rail. Detectable warnings shall extend the full width of the pedestrian walkway.

### 5.36.3 CURB RAMPS

Curb ramps are required at pedestrian road crossings when the walking surface connecting to the roadway surface exceeds a 5% grade.

Curb ramps shall not be located within a driveway; curb ramps and driveways shall be independent of each other without any overlap.

There are three types of curb ramps: perpendicular, parallel, and combination. Perpendicular curb ramps have a running slope that cuts through or is built up to the curb at right angles or meets the gutter break at right angles where the curb is curved. Parallel curb ramps have a running slope that is in-line with the direction of sidewalk travel and lower the sidewalk to a level turning space where a turn is made to enter the pedestrian street crossing. Combination curb ramps consists of a parallel ramp to lower the sidewalk to a mid-landing and a short perpendicular curb ramp connects the landing to the street.

Perpendicular curb ramps are the preferred type of curb ramp, they are not subject to inundation or ponding when runoff is contained within the street. Perpendicular curb ramps are to be used where sufficient right-of-way exists. All curb ramps located along arterial and major collector roads are to be perpendicular ramps. The typical sidewalk offset along arterial and major collector roads allows for the construction of perpendicular ramps.

Combination curb ramps require a ramp curb at the back of the sidewalk to contain street flows. The lowered sidewalk area of a combination curb ramp is subject to periodic flooding from street flows. Combination ramps may be used when existing conditions prevent construction of a perpendicular ramp.

Parallel curb ramps may only be used to retrofit an existing non-compliant condition when insufficient right-of-way or other unrectifiable condition exists that prevents the construction of a perpendicular or a combination curb ramp.

New construction shall install perpendicular radial curb ramps at all curb returns. Curb ramps within curb returns shall be constructed in conformance with MCDOT Detail 2031, MCDOT Detail 2032 or MAG Details 236-1, 236-2 or 236-3. A separate curb ramp is to be provided for each crossing direction. Mid-block curb ramps for new constructions shall be constructed in conformance with MAG Details 238-1, 238-2 and 238-4.

Tee intersections are to provide a pedestrian crossing of both roadways:

- One curb return will have dual ramps per approved MCDOT or MAG Curb Ramp Details.
- The other curb return may use a single approved MCDOT or MAG Curb Ramp Details.

## **5.37 GEOMETRIC STANDARDS FOR PARK ROADS**

### **Originator: Engineering Division**

Public roads within Maricopa County Parks shall be designed in accordance with the following adopted standards:

- ◇ Standards for Maricopa County Parks Roadway System, 2017 Edition, with all current revisions thereto.
- ◇ Standards for Lake Pleasant Regional Park Roadway System, 1992, with all current revisions thereto.

# Chapter 6

## Intersections

TABLE OF CONTENTS

CHAPTER 6 INTERSECTIONS

<b>6.1</b>	<b>GENERAL CONTROLS .....</b>	<b>6-1</b>
	6.1.1 INTERSECTION ANGLE .....	6-1
	6.1.2 INTERSECTION SPACING.....	6-1
	6.1.3 INTERSECTION LOCATION .....	6-1
	6.1.4 INTERSECTION LONGITUDINAL GRADES.....	6-1
	6.1.5 INTERSECTION CROSS SLOPE.....	6-1
	6.1.6 INTERSECTION LANE REQUIREMENTS .....	6-2
	6.1.7 INTERSECTION TURN LANE DESIGN.....	6-4
	6.1.8 LEFT TURN LANE STORAGE.....	6-5
	6.1.9 RIGHT TURN LANE STORAGE .....	6-5
	6.1.10 AUXILIARY LANE TRANSITION TAPERS.....	6-5
	6.1.11 LAYOUT REQUIREMENTS FOR AUXILIARY TURN LANES .....	6-6
	6.1.12 INTERSECTION RETURNS.....	6-7
	6.1.13 INTERSECTION SIGHT DISTANCE .....	6-8
	6.1.14 RIGHT-OF-WAY REQUIREMENTS .....	6-9
<b>6.2</b>	<b>ROUNDABOUTS .....</b>	<b>6-10</b>
	6.2.1 GENERAL.....	6-10
	6.2.2 APPLICABILITY .....	6-11
	6.2.3 DESIGN PROCESS .....	6-11
	6.2.4 GENERAL DESIGN CRITERIA.....	6-11
	6.2.5 SUBMITTAL REQUIREMENTS summary.....	6-15
	6.2.6 VALIDATING LANE NUMBERS AND ARRANGEMENTS .....	6-15
	6.2.7 BASIC DESIGN PRINCIPLES.....	6-17
	6.2.8 GEOMETRIC DESIGN ELEMENTS.....	6-17
	6.2.9 MINI-ROUNDABOUTS.....	6-21
	6.2.10 PERFORMANCE CHECKS .....	6-24
	6.2.11 VERTICAL CONSIDERATIONS .....	6-28
	6.2.12 OTHER DESIGN DETAILS.....	6-29

**LIST OF FIGURES**

FIGURE 6.1: AUXILIARY TURN LANES – CURB TRANSITIONS ..... 6-6  
FIGURE 6.2: LEFT-TURN LANE LAYOUT FOR RURAL PRINCIPAL ARTERIAL ..... 6-6  
FIGURE 6.3(A): LEFT-TURN LANE – WIDENING ONE SIDE ONLY ..... 6-7  
FIGURE 6.3(B): LEFT-TURN LANE – SYMMETRICAL WIDENING..... 6-7  
FIGURE 6.3(C): RIGHT-TURN LANE LAYOUT ..... 6-7  
FIGURE 6.4: GEOMETRIC ELEMENTS OF A ROUNDABOUT ..... 6-10  
FIGURE 6.5: URBAN SINGLE-LANE ROUNDABOUT ..... 6-13  
FIGURE 6.6: URBAN MULTILANE ROUNDABOUT ..... 6-14  
FIGURE 6.7: TRAFFIC VOLUME AND LANE CONFIGURATION DIAGRAMS ..... 6-16  
FIGURE 6.8: SPLITTER ISLAND CURB OFFSETS AND NOSE RADII DIMENSIONS... 6-18  
FIGURE 6.9: DESIGN VEHICLE CURB CLEARANCES ..... 6-19  
FIGURE 6.10: ENTRY PATH ALIGNMENT – AVOID PATH OVERLAP..... 6-20  
FIGURE 6.11: URBAN MINI-ROUNDABOUT TYPICAL LAYOUT ..... 6-22  
FIGURE 6.12: TYPICAL DIMENSIONS FOR MINI-ROUNDABOUTS ..... 6-23  
FIGURE 6.13: VEHICLE PATH RADII ..... 6-24  
FIGURE 6.14: FASTEST PATH EXHIBIT ..... 6-25  
FIGURE 6.15: STOPPING SIGHT DISTANCE ON APPROACH ..... 6-25  
FIGURE 6.16: STOPPING SIGHT DISTANCE ALONG CIRCULATING ROADWAY .... 6-26  
FIGURE 6.17: STOPPING SIGHT DISTANCE TO CROSSWALK ON EXIT ..... 6-26  
FIGURE 6.18: INTERSECTION SIGHT DISTANCE..... 6-27  
FIGURE 6.19: COMPOSITE SIGHT DISTANCE DIAGRAM..... 6-27  
FIGURE 6.20: ELEVATION CONTROL REQUIREMENTS ..... 6-29

**LIST OF TABLES**

TABLE 6.1: VOLUME WARRANTS FOR RIGHT-TURN LANES ..... 6-3  
TABLE 6.2: VOLUME WARRANTS FOR LEFT-TURN LANES ..... 6-3  
TABLE 6.3: RETURN RADIUS..... 6-8  
TABLE 6.4: VEHICLE TYPE FOR DETERMINING DEPARTURE SIGHT TRIANGLES .. 6-9  
TABLE 6.5: ROUNDABOUTS – GENERAL DESIGN REQUIREMENTS ..... 6-12

## **6.1 GENERAL CONTROLS**

### **Originator: Transportation Systems Management & Operations Division**

This Chapter 6 applies to the design of intersections between two or more roadways each within the public right-of-way of a governing jurisdiction and each of the intersecting roadways is maintained by the governing jurisdiction. Other public and private roads accessing the County road system are to be compliant with Chapter 7 and may also be required to comply with elements contained in this Chapter.

#### **6.1.1 INTERSECTION ANGLE**

Roads shall intersect each other at not more than 10 degrees from normal.

#### **6.1.2 INTERSECTION SPACING**

Signalized intersections are preferred to be spaced at half mile intervals on arterial streets, with quarter mile intervals as a minimum spacing. Non-signalized intersections are to be spaced at least 660 feet apart on arterial roads. Two adjacent 'tee' intersections are to be avoided. It is desirable to align the 'two' intersections to create a single 4-legged intersection. If alignment of two 'tee' intersections cannot be accomplished, adjacent 'tee' intersections are to be spaced a minimum distance of 660 feet between them, or if acceptable to MCDOT the minimum storage and taper requirements for back to back left turn lanes based on future traffic volumes.

The minimum spacing for intersections along collector roads is a nominal 360 feet.

Intersections located along local residential streets shall have a minimum of 75 feet separating the rights of way of the two intersecting streets.

#### **6.1.3 INTERSECTION LOCATION**

Intersecting roads are to have relatively straight approaches such that the stopping and intersection sight distances are provided on all approaches to the intersection.

#### **6.1.4 INTERSECTION LONGITUDINAL GRADES**

When feasible the longitudinal grade through intersections should not exceed two percent. The purpose of this requirement is to keep the cross slope of pedestrian crosswalk areas compliant with the ADA standard of a maximum two percent cross slope for pedestrian access routes.

#### **6.1.5 INTERSECTION CROSS SLOPE**

The cross slope may vary from 0.005 to 0.03 foot per foot for intersection transition areas.

The design control at the crossover crown line of two adjacent pavements is the algebraic difference in the cross slope rates. Where both pavements slope down and away from the crossover

crown line, the algebraic difference is the sum of their cross slope rates; where they slope in the same direction, it is the difference of their cross slope rates. The maximum algebraic difference at a crossover crown line shall not exceed 4.0%.

Signal installation is likely to occur at arterial to arterial intersections and at arterial to major collector intersections. At intersections where signal installation is likely to occur, the vertical design of the through travel lanes of the road having the highest design speed with the highest classification is to comply with the geometric requirements of Section 5.11. Where signal installation is likely to occur, the maximum crown break-over angle for asphalt pavement shall not exceed 1.5 percent. Reducing roadway cross slopes to 0.005 foot per foot through intersections will provide an acceptable break-over angle for asphalt roadways since the asphalt material will not form a sharp break-over angle. For intersections constructed with portland cement concrete pavement a sharp break-over crown line is to be avoided by providing spot elevations that approximate a parabolic curve.

The maximum grade break on a stop sign controlled residential or minor collector street at a valley gutter shall be 8.0%.

### **6.1.6 INTERSECTION LANE REQUIREMENTS**

A traffic analysis is required to determine the number of lanes and the lane configuration for intersections. The desired level of service is dependent on roadway classifications; the minimum desired LOS is D. The turn bay requirements presented in Sections 6.1.6a and 6.1.6b are based on turning movement volumes and take precedence over LOS analysis.

Developments, new construction, and major reconstruction projects are to construct auxiliary lanes when the following warrants are met.

#### **A. Right Turn Lane Warrants:**

1. Existing and/or Design Year peak hour right turn volumes meet or exceed the ranges presented in Table 6.1.
2. On any roadway that does not meet the requirements of Table 6.1 and a traffic impact analysis indicates the LOS would be improved to an acceptable LOS, based on roadway classification, or better with the addition of a right-turn lane.
3. Engineering judgment indicates a right-turn deceleration lane is warranted based on factors including shoulder width, percentage of trucks, sign distance, roadway grade, horizontal and vertical curvature, and crash history.

If the expected peak hour turning volume exceeds 300 vehicles per hour, dual right turn lanes should be considered.

<b>TABLE 6.1: VOLUME WARRANTS FOR RIGHT-TURN LANES</b>					
Peak Hour Traffic Volume on the Roadway in Advancing Direction	Minimum Peak Hour Right-Turn Traffic Volume				
	# of thru lanes per direction				
	1		2		3
	< 45 MPH Posted Speed	≥ 45 MPH Posted Speed	< 45 MPH Posted Speed	≥ 45 MPH Posted Speed	All Speeds
≤ 200	-	-	-	-	-
201 -300	-	30	-	-	-
301 – 400	-	19	-	55	-
401 – 500	85	14	-	30	-
501 – 600	58	12	140	25	-
601 – 700	27	9	80	18	-
701 – 800	20	8	53	15	-
801 – 900	12	7	40	12	-
901 – 1000	9	6	30	11	-
1001 – 1100	8	5	23	9	18
1101 - 1200	7	5	18	8	16
1201 – 1300	6	4	14	8	15
1301 – 1400	6	4	11	6	12
1400 +	5	3	8	6	10

**B. Left Turn Lane Warrants:**

1. Left turns shall be provided at all signalized intersections.
2. Existing and/or Design Year peak hour left turn volumes meet or exceed the ranges presented in Table 6.2.
3. On any roadway that does not meet the requirements of Table 6.2 but a traffic impact analysis indicates the LOS would be improved to an acceptable LOS, based on roadway classification, or better with the addition of a left-turn lane.

<b>TABLE 6.2: VOLUME WARRANTS FOR LEFT-TURN LANES</b>				
Peak Hour Traffic Volume on the Roadway in Advancing Direction	Minimum Peak Hour Left-Turn Traffic Volume			
	# of thru lanes per direction			
	1		2	
	< 45 MPH Posted Speed	≥ 45 MPH Posted Speed	< 45 MPH Posted Speed	≥ 45 MPH Posted Speed
≤ 200	30	15	-	-
201 -300	12	12	40	30
301 – 400	12	12	30	25
401 – 500	12	12	25	18
501 – 600	12	12	15	12
601 – 1000	12	12	10	8
1000 +	12	8	10	8

The threshold volumes used to determine the need for turn lanes are based on a normal mix of design vehicle types, the volume limits may be adjusted at the discretion of the County Traffic Engineer.

In some circumstances, left turn lanes may not be required at signalized intersections; those intersections will generally require split-phase signal operation and will be evaluated by MCDOT Traffic Management on a case by case basis.

**C. Dual Left-Turn Lanes are to be provided when:**

1. The peak hour left-turn volume exceeds 300 vehicles per hour.
2. The peak hour conflicting through movement volume exceeds 1,000 vehicles per hour.
3. A traffic impact analysis indicates the LOS would be increased to a LOS of D or better with the addition of dual left turns.

The threshold volumes used to determine the need for turn lanes are based on a normal mix of design vehicle types, the volume limits may be adjusted at the discretion of the Traffic Engineer.

In some circumstances, left turn lanes may not be required at signalized intersections; those intersections will generally require split phase signal operation and will be evaluated by MCDOT Traffic Management on a case by case basis.

**6.1.7 INTERSECTION TURN LANE DESIGN**

Intersections are to be designed to allow the passenger car (P) design vehicles approaching from opposite directions to turn left simultaneously without conflict with each other. At arterial-arterial intersections two WB-50 design vehicles approaching from opposite directions are to be able to turn left simultaneously without conflict.

Where additional turn lanes, raised medians or other modifications to the standard typical section cause the median width to increase, this increased width will be limited to the intersection area.

The design of signalized intersections shall provide sufficient turning space to accommodate design vehicle offtracking for both right and left turns on all approaches. The design vehicle for signalized intersection design is as defined in Section 4.1.2 DESIGN VEHICLE. Design vehicle offtracking shall not cause any part of the design vehicle to encroach into an opposing traffic lane, opposing left turn lane, or extend beyond the face of any curb or any pavement edge. Widening of the receiving lane or lanes is to be provided as needed to accommodate the design vehicle's offtracking turning movements. Receiving lane widening (throat widening) can be accomplished using an asymmetric three centered curve or an offset curve with a closing taper section.

At intersections with dual left turn lanes and three receiving lanes on the exit portion of the intersection are usually needed to accommodate truck turning movements. The outside left turn lane and the two exterior receiving lanes on the exit portion of the intersection are used to accommodate the truck turning path of a WB-50 design vehicle. When only two receiving lanes are available then the exterior lane shall have sufficient throat widening to allow the design vehicle to turn without encroaching onto the interior receiving lane or exterior curb.

Right turns onto an arterial roadway by the WB-50 design vehicle shall not encroach into the opposing traffic or left turn lane. Lane widening shall be provided as needed to accommodate the truck turning movement.

The design vehicle's turning template is to be used to ensure sufficient width is provided to accommodate offtracking turning movements. Receiving lane widening (throat widening) shall be provided as needed to accommodate the offtracking turning movements.

For arterial and collector roads the storage length for auxiliary turn lanes is to be determined by a traffic analysis for both signalized and unsignalized intersections. The minimum storage for both collectors and arterials is generally the same due to the possibility of collector roadways becoming signalized at a future date. The storage criteria shown below will apply to both urban and rural conditions.

Exception to the minimum turn lane storage requirements shown below may be granted by the MCDOT Traffic Engineer.

#### **6.1.8 LEFT TURN LANE STORAGE**

For arterials and collector roads, the minimum storage length is 160 feet. This will apply to both signalized and unsignalized intersections. For local roads the minimum storage length is 75 feet.

#### **6.1.9 RIGHT TURN LANE STORAGE**

For arterials and collector roads, the minimum storage length is 160 feet. This will apply to both signalized and unsignalized intersections.

#### **6.1.10 AUXILIARY LANE TRANSITION TAPERS**

Opening tapers for auxiliary turn lanes without curbing are to be added with an opening taper rate of 8:1 (L:W) minimum and 15:1 (L:W) maximum. Use an 8:1 opening taper for design speeds of 30 mph or less and a 15:1 opening taper for design speeds of 50 mph or greater.

For auxiliary lanes with curbing provide reverse curves as illustrated in Fig. 6.1.

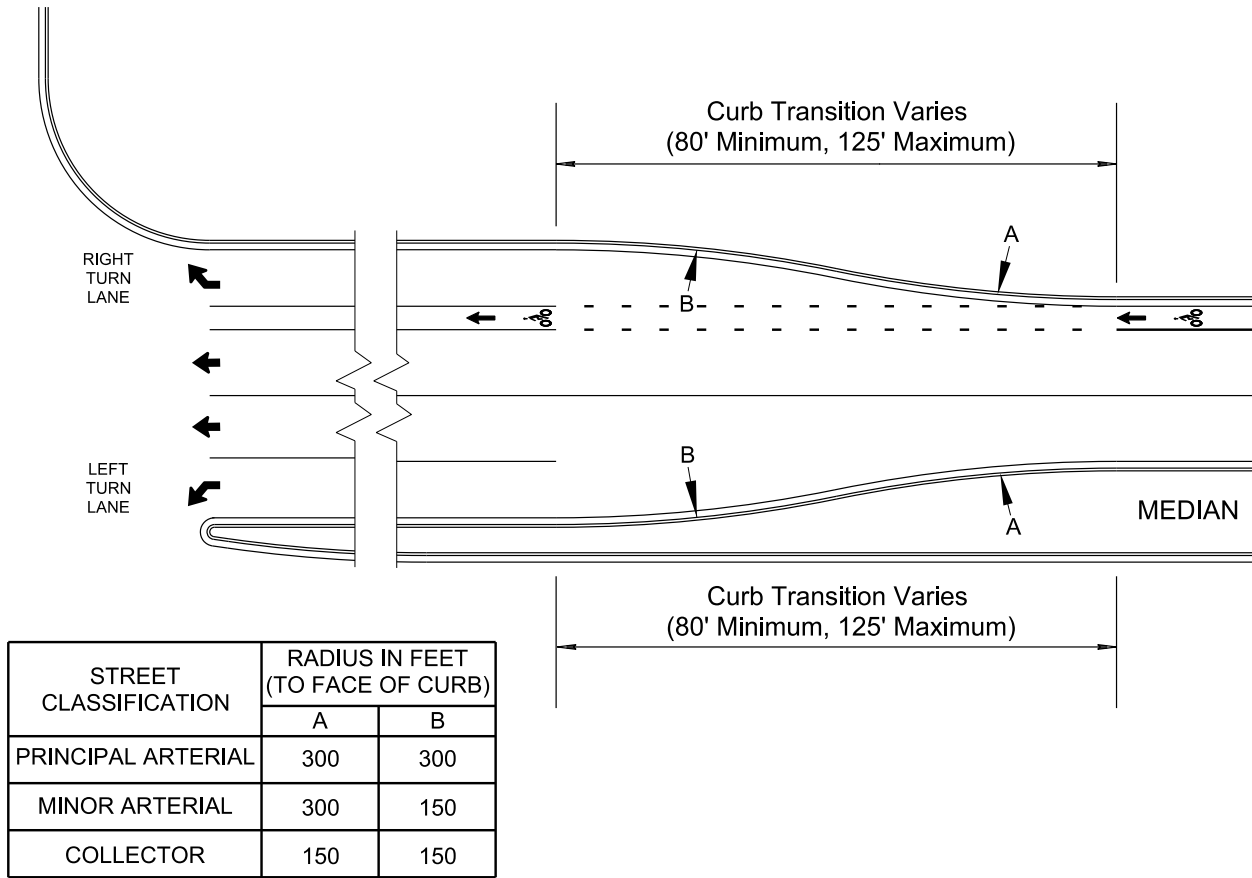


FIGURE 6.1: AUXILIARY TURN LANES – CURB TRANSITIONS

6.1.11 LAYOUT REQUIREMENTS FOR AUXILIARY TURN LANES

Figure 6.2 shows a left turn auxiliary lane layout for a rural principal arterial.

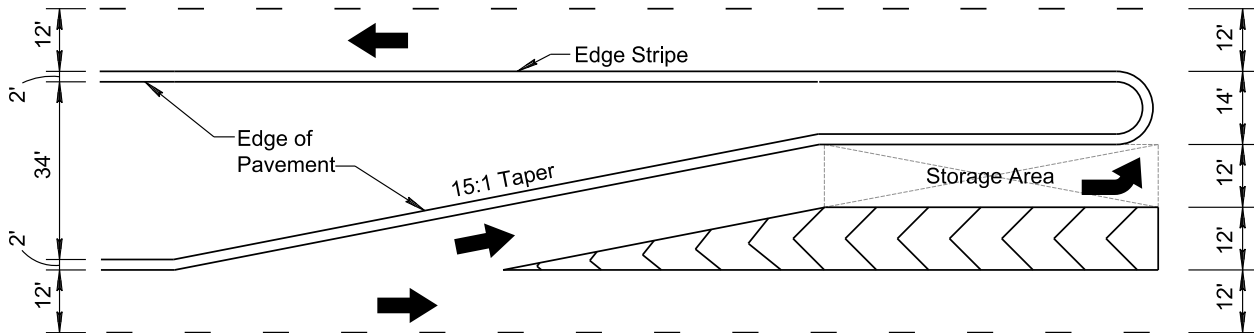
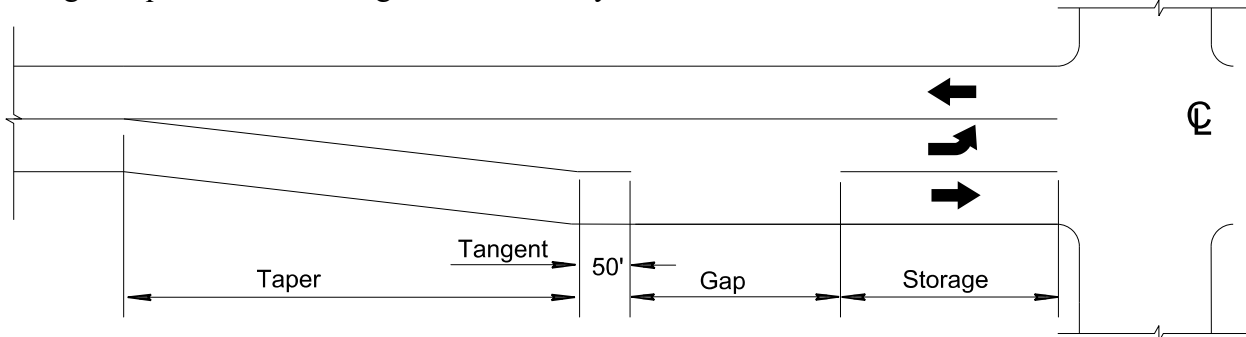


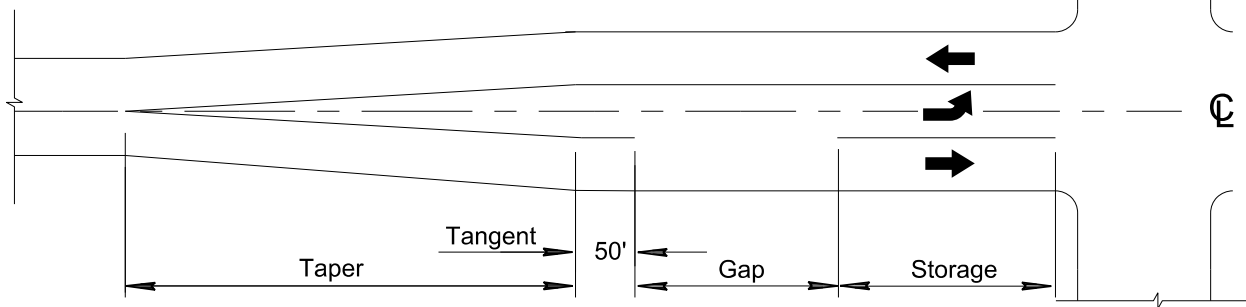
FIGURE 6.2: LEFT-TURN LANE LAYOUT FOR RURAL PRINCIPAL ARTERIAL

Figures 6.3(A) and 6.3(B) illustrate potential methods for adding a left turn lane to a two lane roadway. Note that the offset distance for symmetrical widening is half the distance as required for widening on one side only, therefore the taper length for symmetrical widening is half the length required for widening on one side only.

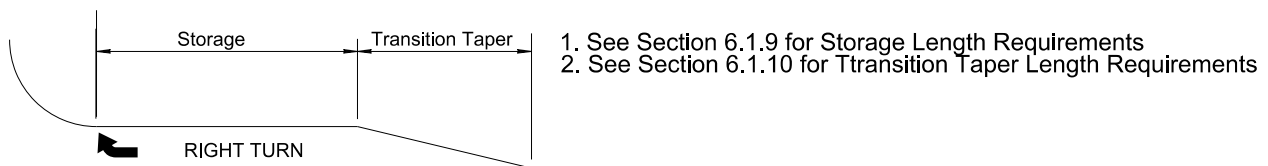


**FIGURE 6.3(A): LEFT-TURN LANE – WIDENING ONE SIDE ONLY**

Minimum Gap Length for Left Turn Lanes	
Posted Speed (mph)	Minimum Opening (feet)
45 or less	100'
50 or more	120'



**FIGURE 6.3(B): LEFT-TURN LANE – SYMMETRICAL WIDENING**



**FIGURE 6.3(C): RIGHT-TURN LANE LAYOUT**

### 6.1.12 INTERSECTION RETURNS

The radii for returns at intersections shall be measured to the face of the curb or if no curb to the edge of pavement. The minimum radii shall be in accordance with Table 6.3. The return radius point may need to be offset from the adjacent roadway curb lines to provide throat widening of the receiving lanes to accommodate design vehicle off tracking.

TABLE 6.3: RETURN RADIUS		
TYPE OF ROAD	RETURN RADIUS* WITH CURB AND GUTTER (FT.)	RETURN RADIUS* WITHOUT CURB AND GUTTER (FT.)
Arterial With Arterial	35	45
Arterial With Major Collector	35	45
Arterial With Minor Collector	30	45
Arterial With Residential	30	35
Major Collector With Major Collector	30	35
Major Collector With Minor Collector	30	30
Major Collector With Residential	30	30
Minor Collector With Minor Collector	30	30
Minor Collector With Residential	20	30
Residential With Residential	20	20
* Return radii for roadways serving industrial and commercial developments shall not use a radius less than 30-feet; use of three centered curves is preferred.		

Return radii for parkways shall be the same as required for arterial roadways, except where turning movements are not allowed.

### 6.1.13 INTERSECTION SIGHT DISTANCE

Where left turning traffic must yield to on-coming traffic, provide a minimum of 3.5 feet of positive offset for opposing left-turn lanes to ensure adequate sight distance for left-turning drivers.

Clear sight triangles shall be provided at all intersections. The type of sight triangle (approach or departure) will depend on the type of intersection control provided. The dimensions of the sight triangles are to be determined in compliance with the procedures identified in the AASHTO publication *A Policy on Geometric Design of Highways and Streets*.

Departure sight triangles shall be calculated using the vehicle type shown in Table 6.4 and the decision point (vertex of the clear sight triangle) shall be located eighteen foot (18.0') back from the near edge of arterial roads and fourteen and a half feet (14.5') from the near edge of collector and local roads. Departure clear sight triangles shall be contained within the road right-of-way to ensure sight obstructions are not placed within the sight triangles.

**TABLE 6.4: VEHICLE TYPE FOR DETERMINING DEPARTURE SIGHT TRIANGLES**

Major Road Classification	Minor Road Classification	Vehicle 1		
		Right Turn	Left Turn	Cross
Arterial	Arterial	Combination Truck	Combination Truck	Single Unit Truck
Arterial	Collector	Single Unit Truck	Single Unit Truck	Single Unit Truck
Arterial	Local	Single Unit Truck	Single Unit Truck	Single Unit Truck
Collector	Collector	Single Unit Truck	Single Unit Truck	Single Unit Truck
Collector	Local	Single Unit Truck	Single Unit Truck	Single Unit Truck
Local	Local	Single Unit Truck	Single Unit Truck	Single Unit Truck
Residential Subdivision Local	Residential Subdivision Local	Passenger Car	Passenger Car	Passenger Car

#### 6.1.14 RIGHT-OF-WAY REQUIREMENTS

Right-of-way at intersections shall include all areas within the intersection departure sight triangles. A Sight Visibility Easement in lieu of right-of-way may be provided for areas where the departure sight triangle extends beyond the corner lot. The Sight Visibility Easement is to restrict plantings and construction that may obstruct visibility and require the property owner to maintain unobstructed sight visibility within the departure sight triangle.

Where the standard roadway width is increased for auxiliary lanes or bus stops, the right-of-way shall be increased to accommodate sidewalk at the standard offset distance behind the widened roadway curb line plus a minimum of 2.5 feet between the back of sidewalk and the right-of-way line.

## 6.2 ROUNDABOUTS

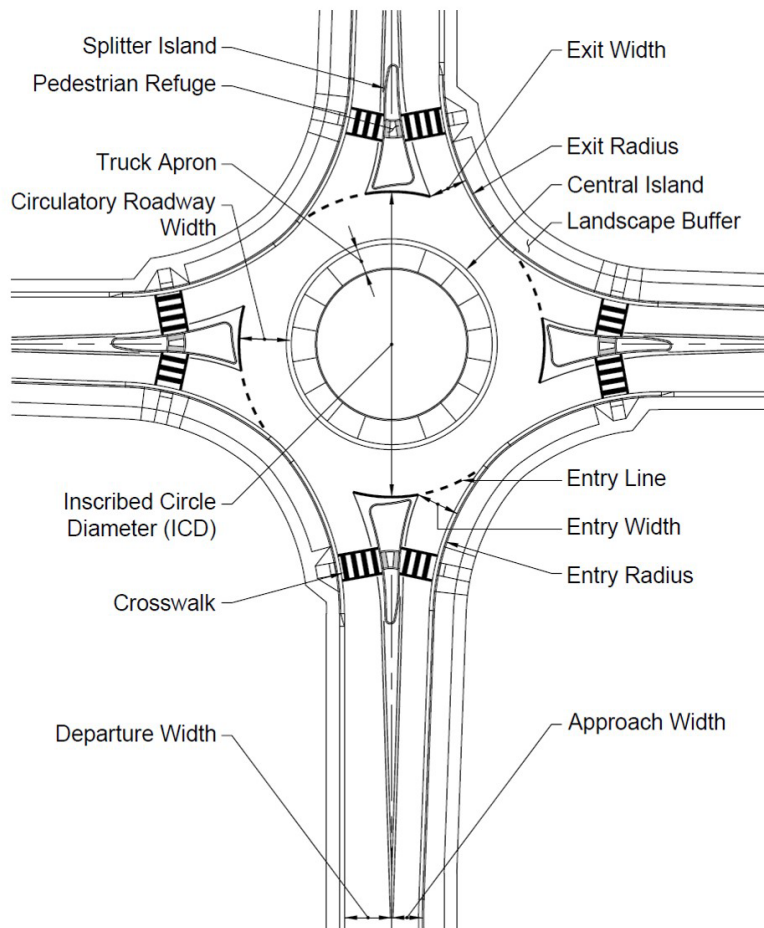
### Originator: Transportation Systems Management & Operations Division

#### 6.2.1 GENERAL

A modern roundabout is a type of circular intersection characterized by channelized approaches, yield control at entry, counterclockwise circulation around a central island, and geometric features that create a low-speed environment. Roundabouts offer safety, operational, and other advantages over conventional intersections including fewer conflict points, lower speeds, improved traffic flow, lower fuel consumption, and reduced air pollution.

All roundabout designs are to comply with Transportation Research Board (TRB) National Cooperative Highway Research Program (NCHRP) Report 672 *Roundabouts: An Informational Guide, Second Edition* produced in cooperation with the U.S. Department of Transportation, Federal Highway Administration (FHWA).

Figure 6.4 identifies various design features of the modern roundabout.



**FIGURE 6.4: GEOMETRIC ELEMENTS OF A ROUNDABOUT**

### **6.2.2 APPLICABILITY**

Roundabouts may provide beneficial advantages over a conventional intersection for any of the following conditions:

1. Where stop controls (stop signs or signals) are causing unnecessary delay;
2. Where there is a high left turn percentage on one or more legs;
3. Where there have been a disproportionately high number of head on or right angle collisions;
4. Where it is not desirable to give priority to either street; and
5. Where there is unusual intersection geometry.

Certain physical or geometric complications may make it uneconomical or ineffective to construct a roundabout at the location being evaluated. These could include right of way limitations, utility conflicts, drainage problems, and proximity of significant traffic generators or traffic control devices requiring pre-emption, as needed at railroad crossings. Specific conditions in which the use of roundabouts will be unacceptable include the following:

1. Where roadway grade exceeds 4%;
2. Where there is inadequate sight distance;
3. Where major roadway ADT exceeds 90% of total intersection ADT;
4. Where high volumes of pedestrians with special needs would have difficulty crossing the road.
5. Where a downstream traffic control device such as a traffic signal would result in a queue that extends into the functional area of the roundabout
6. At a single intersection within coordinated signal network.

### **6.2.3 DESIGN PROCESS**

The design process for roundabouts is usually an iterative process of evaluating the geometric layout for operational performance, and safety. Minor adjustments in geometry can result in significant changes in the safety and/or operational performance. Thus, the designer often needs to revise and refine the initial layout attempt to enhance its capacity and safety. NCHRP Report 672 Exhibit 6-1 provides a general outline for the design process with cross-references to other sections of the Report for each individual step within the process.

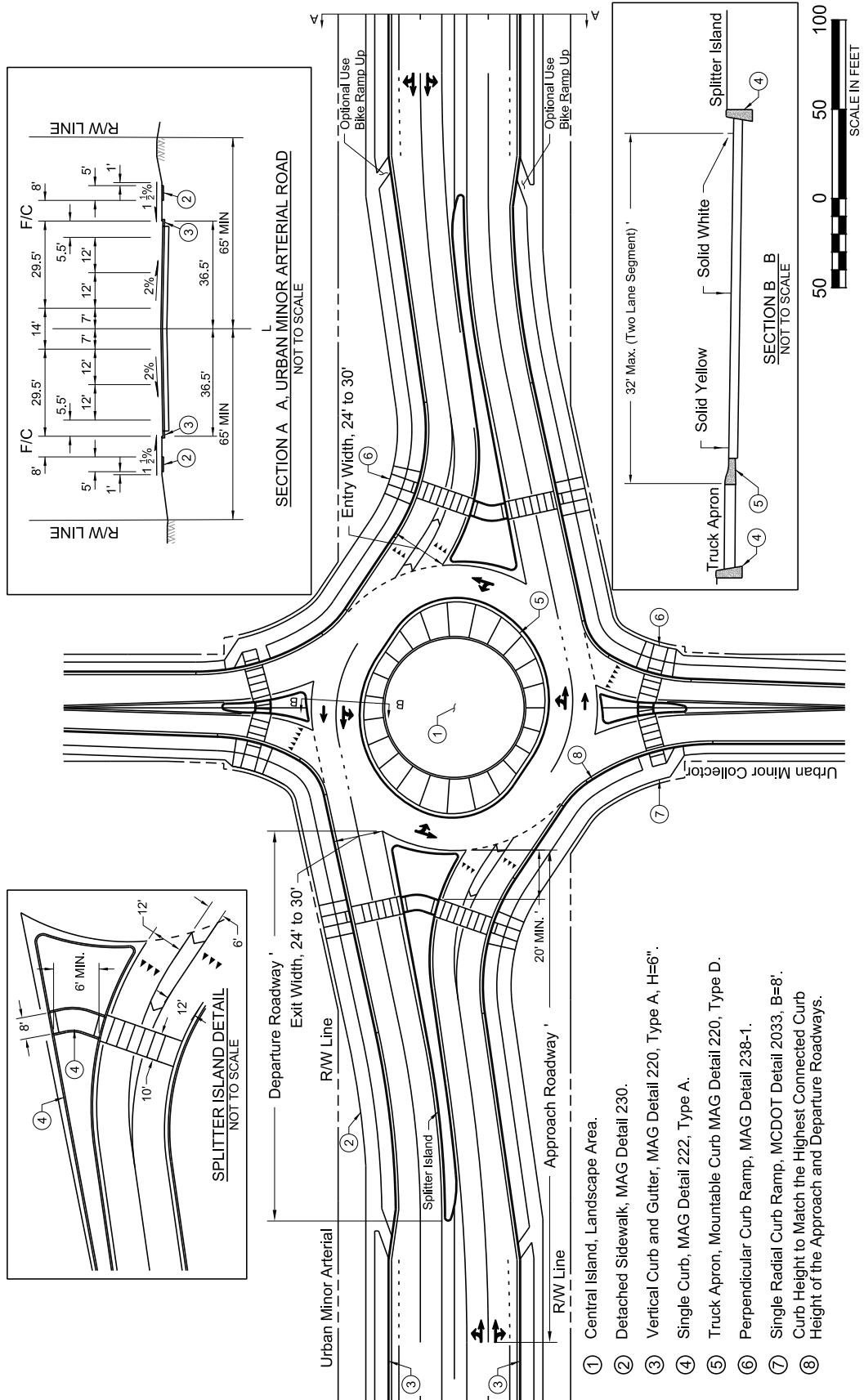
### **6.2.4 GENERAL DESIGN CRITERIA**

Table 6.5 identifies criteria to be used for roundabout design based on the classification of the approach roadways.

<b>TABLE 6.5: ROUNDABOUTS – GENERAL DESIGN REQUIREMENTS</b>			
<b>Feature/Parameter</b>	<b>Mini-Roundabout</b>	<b>Single-Lane Roundabout</b>	<b>Multilane Roundabout<sup>(1)</sup></b>
Approach Roadway Classifications	Minor Collector Local Residential	Major Collector Minor Collector Local Residential	Principal Arterial Minor Arterial Major Collector Minor Collector
Maximum Entry Speed and Maximum Circulating Speed	20 mph	25 mph	30 mph
Typical Inscribed Circle Diameter (ICD)	90 feet	110-150 feet	140-200 feet
Design Vehicle (Exterior Circulating Lane(s))	S-BUS-40	BUS-40 <sup>(4)</sup>	WB-50 <sup>(2)</sup>
Design Vehicle (Interior Circulating Lane + Truck Apron)	Not Applicable	WB-50	WB-62 <sup>(3)</sup>
Design Vehicle (Circulating Lane + Central Island)	WB-50	Not Applicable	
(1) Values provided are for two-lane configurations. (2) Exterior circulating lanes are to be designed to accommodate in-lane all through movements of WB-50 vehicles. Exterior circulating lanes connecting arterial-to-arterial roadways are to be designed to accommodate in-lane through movements of WB-67 vehicles. (3) WB-62 and WB-67 vehicles may use the interior circulating lane with the adjacent truck apron for through and turning movements. WB-50 vehicles may use the interior circulating lane with the adjacent truck apron for turning movements, through movements are to be accommodated in-lane. The BUS-40 vehicle shall not use the truck apron. (4) The S-BUS-40 design vehicle may be used as the design vehicle for Single-Lane roundabouts connecting only Local Residential and Minor Collector roads.			

Figures 6.5 and 6.6 are geometric layout examples for a single lane roundabout and a multilane roundabout. The right-of-way shown is the minimum required for construction of the roadway and pedestrian facilities. Additional right-of-way area or an easement is needed to protect sight lines.





**FIGURE 6.6: URBAN MULTILANE ROUNDABOUT**

## 6.2.5 SUBMITTAL REQUIREMENTS SUMMARY

In addition to plan review requirements specified elsewhere in this Manual, all roundabout design submittals shall include the following supporting documentation:

1. Capacity analysis documentation as further specified in Section 6.2.6
2. Design vehicle tracking documentation as further specified in Section 6.2.10
3. Fastest Path documentation as further specified in Section 6.2.10
4. Sight distance documentation as further specified in Section 6.2.10

## 6.2.6 VALIDATING LANE NUMBERS AND ARRANGEMENTS

The number of entering, circulating, and exiting lanes at roundabouts has a pronounced effect on roundabout operation. In general, it is desirable to provide only enough lanes necessary to provide acceptable capacity. Fewer lanes provide less complex operation, which generally translates into improved safety. The number and assignment of approach lanes is to be determined for each approach in accordance with the guidelines and procedures outlined in the Roundabouts chapter of the most current edition of the Highway Capacity Manual (HCM).

All roundabout designs must be supported by a documented roundabout capacity analysis demonstrating adequacy of the proposed number and arrangement of lanes to accommodate design year design hour traffic volumes consistent with the requirements stated in Section 2.2 of this Manual. Adequacy is to be confirmed for both AM and PM peak hours for both the opening year and design year. The scope of the required analysis is at the discretion of the County Traffic Engineer and will depend on the type of roundabout being proposed (mini-, single-lane or multilane), the context within which the roundabout is being proposed (new construction or retrofit), and the proximity of the proposed roundabout to existing and planned future adjacent intersections, driveways and other features with which the roundabout's design must be coordinated.

At a minimum, analysis documentation shall include input parameter values represented graphically as generally depicted Figure 6.7, along with a reporting of volume-to-capacity ratio, control delay, level of service and 95<sup>th</sup> percentile queue for each approach, under opening year conditions and design year conditions, respectively. If the roundabout will open with lane geometry that is different from what is needed to accommodate design year conditions, the expected life of the interim lane geometry is to be indicated, as is the way transition between interim and ultimate geometry will be accomplished. For those roundabouts proposed for locations that will be located less than a half mile from a signalized intersection, an at-grade railroad crossing and/or another roundabout, additional analysis which considers the effects of upstream and downstream traffic control may be required at the discretion of the County Traffic Engineer. Similarly, for those roundabouts proposed to replace existing traffic control (retrofit applications) additional analysis justifying the conversion of traffic control/configuration from conventional intersection to a roundabout may be required at the discretion of the County Traffic Engineer.

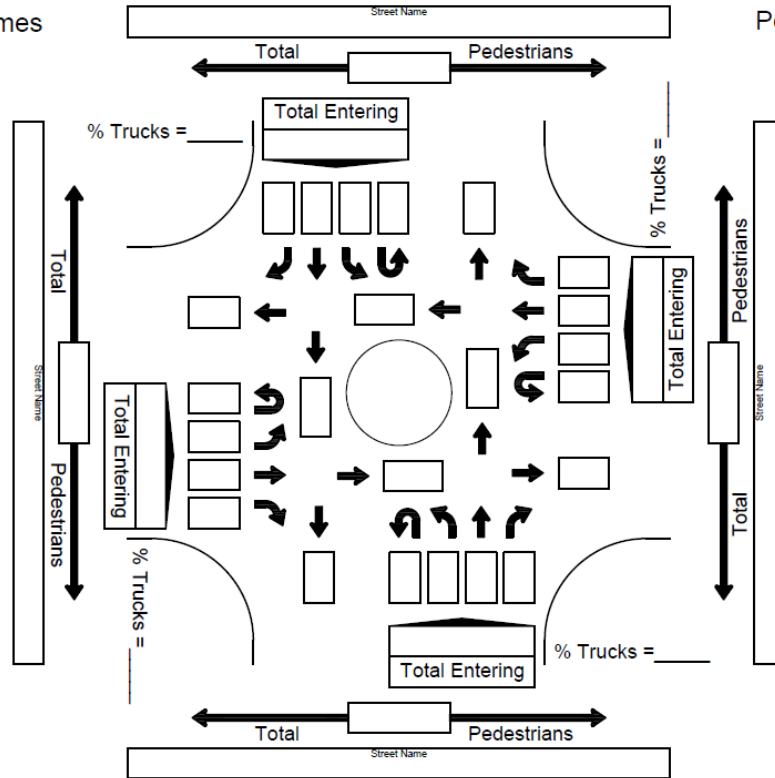
# MCDOT Roadway Design Manual

## Traffic Flow Diagram

Intersection		Analysis Year	
Project No.	Prepared By	Date Prepared	

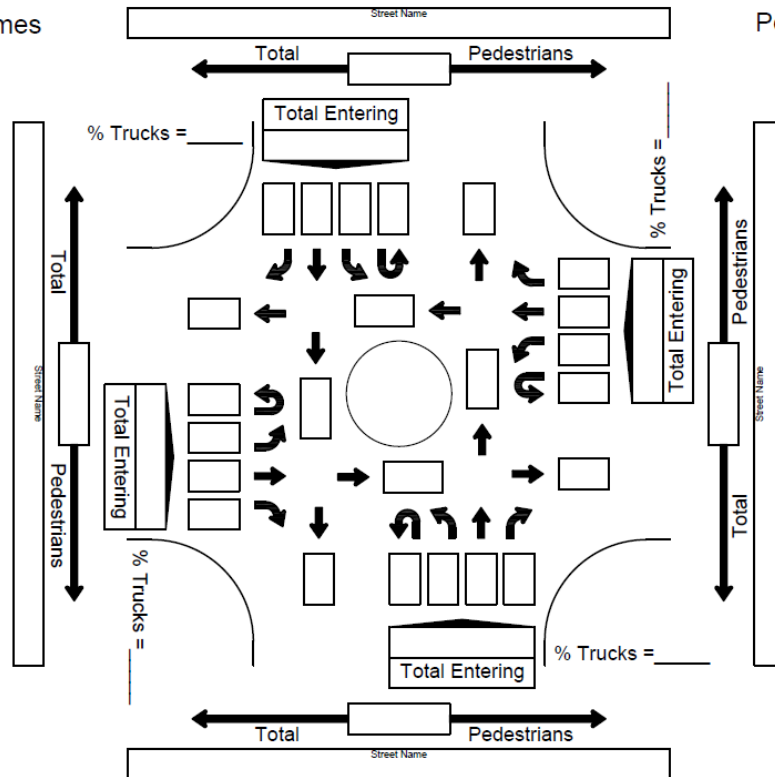
AM Peak Hour Volumes

Peak Hour Factor \_\_\_\_\_



PM Peak Hour Volumes

Peak Hour Factor \_\_\_\_\_



**FIGURE 6.7: TRAFFIC VOLUME AND LANE CONFIGURATION DIAGRAMS**

## **6.2.7 BASIC DESIGN PRINCIPLES**

Fundamentally, the principles of roundabout design are the same as for other types of intersections. The designer must consider the context of the project and provide suitable geometry and traffic control devices, per established engineering principles. The following principles govern all roundabout designs:

1. Cause slow entry speeds and consistent speeds through the roundabout by using deflection.
2. Provide the appropriate number, type, and arrangement of lanes to achieve adequate capacity, lane volume balance, and lane continuity.
3. Provide smooth channelization that is intuitive to drivers and results in vehicles naturally using the intended lanes.
4. Provide adequate accommodation for design vehicles. The swept path for design vehicles is not to encroach onto an adjacent travel lane.
5. Provide appropriate sight distance and visibility for driver recognition of the intersection and conflicting users.
6. Design to meet the needs of pedestrians and cyclists.

## **6.2.8 GEOMETRIC DESIGN ELEMENTS**

### **6.2.8.1 INSCRIBED CIRCLE DIAMETER (ICD)**

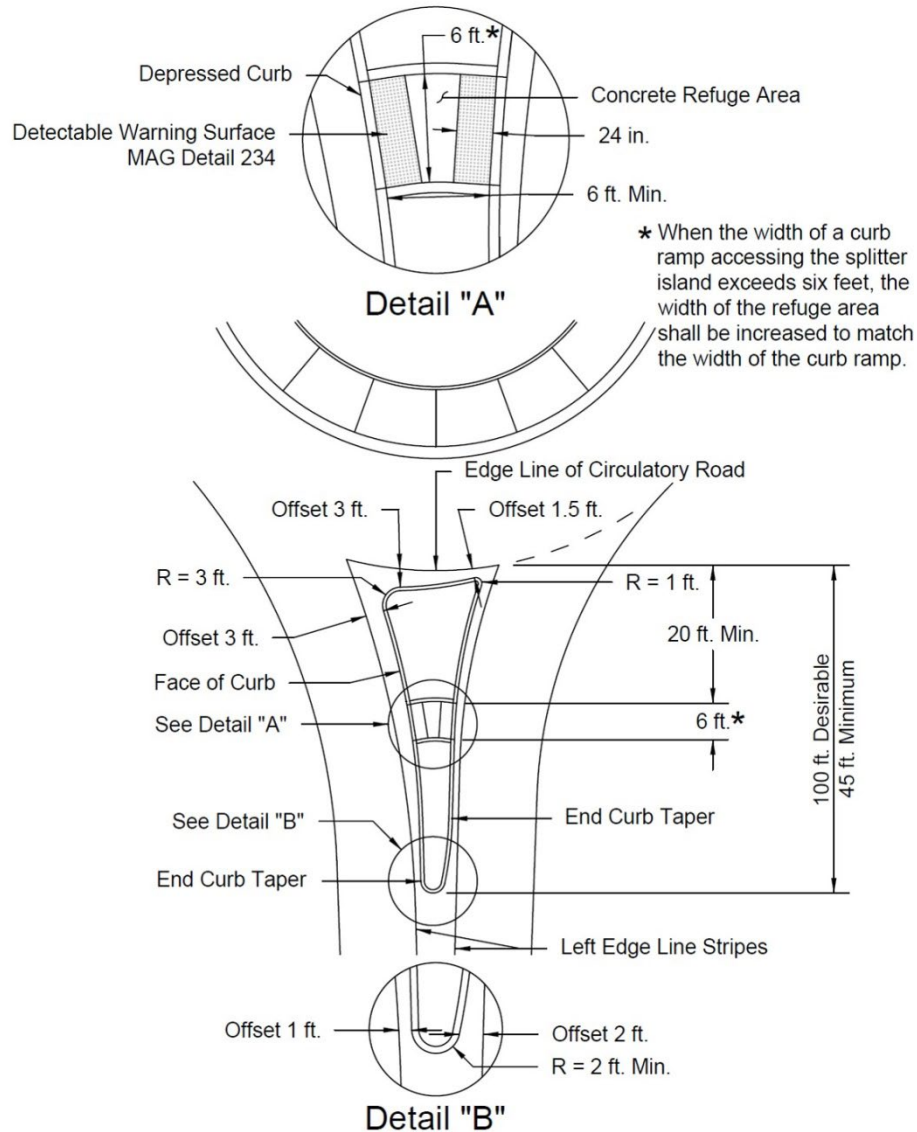
Have the inscribed circle diameter be the minimum required to accommodate the design vehicle, the desired number of lanes, the maximum desired entry speed, and the maximum desired circulating speed. For a WB-50 design vehicle the minimum inscribed circle diameter for a single-lane roundabout should be 110 feet. Additional guidance on ICD dimensioning is provided in Table 6.5.

### **6.2.8.2 APPROACH ALIGNMENT**

The most critical roundabout design objective is to cause low and consistent speeds into and through the roundabout. This condition is created primarily by curb geometry which causes deflection, and should begin on the approach to the yield line. Refer to NCHRP Report 672 Section 6.3.2 for a detailed discussion on the role approach alignment plays in the design of a roundabout and the advantages and disadvantages of various approach alignment alternatives.

### **6.2.8.3 SPLITTER ISLANDS**

Splitter islands are to be designed to control vehicle speeds through path deflection, prevent exiting traffic from accidentally crossing into the path of approaching traffic, reinforce one-way circulation, and provide (with the possible exception of mini-roundabouts) a pedestrian refuge area. The pedestrian cross through refuge area shall be six feet (6') wide. When the width of a curb ramp accessing the splitter island exceeds six feet, the width of the refuge area shall be increased to match the width of the curb ramp. Figure 6.8 provides additional guidance in the sizing and positioning/orientation of critical splitter island design elements.



**FIGURE 6.8: SPLITTER ISLAND CURB OFFSETS AND NOSE RADII DIMENSIONS**

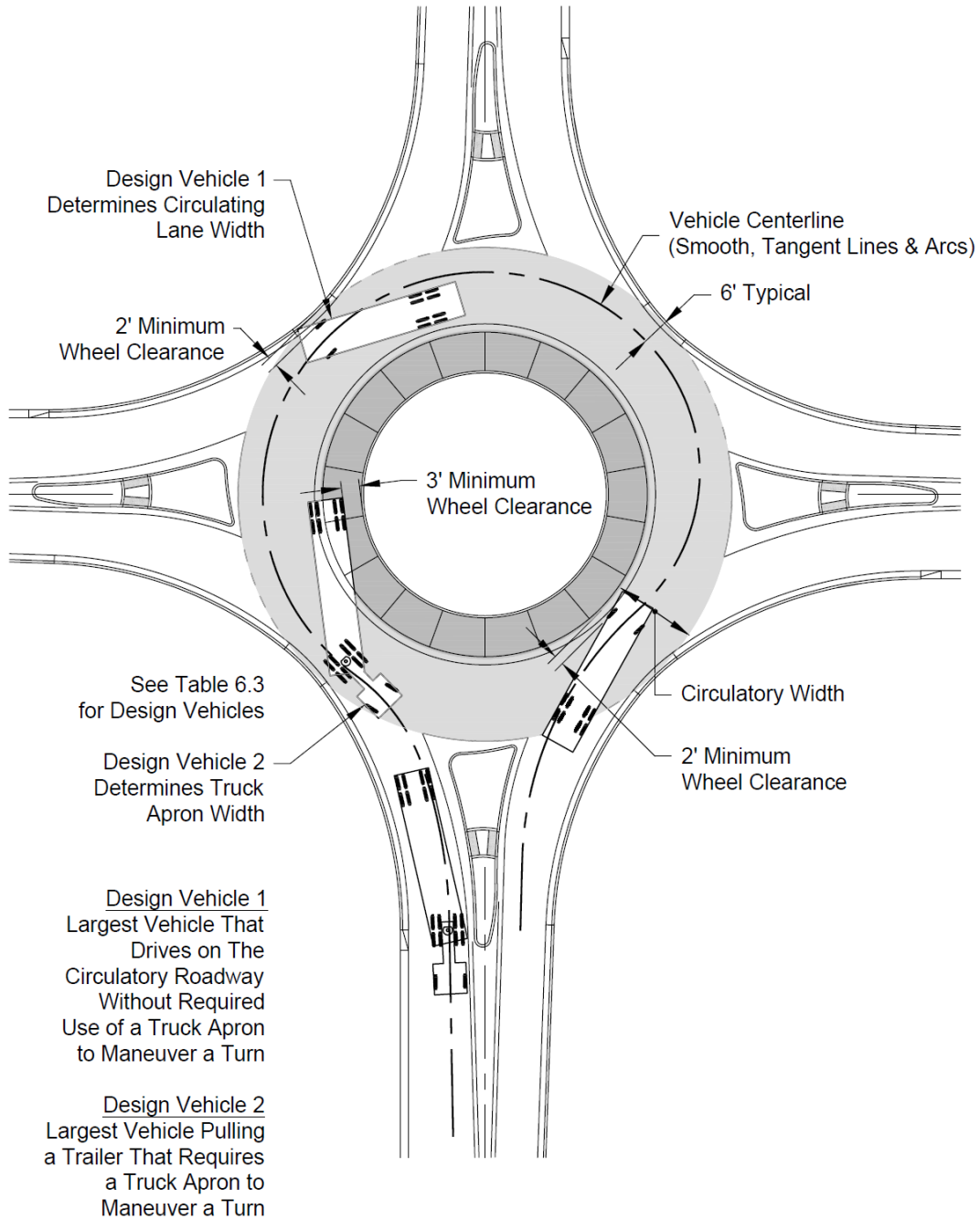
**6.2.8.4 ENTRY WIDTH**

The entry width is measured from the point where the yield line intersects the left edge of the traveled way to the right edge of the traveled way, along a line perpendicular to the right curb line. Entry width should be kept to a minimum to maximize the safety of the roundabout and wide enough to accommodate the largest design vehicle. Typical entry widths range from 14-18 feet for single-lane entrances and 28-32 feet for two-lane entrances.

**6.2.8.5 CIRCULATORY ROADWAY WIDTH**

The width of the circulatory roadway should be at least as wide as the maximum entry width, no more than 1.2 times the entry width, and remain constant throughout the roundabout. Appropriate vehicle templates shall be used to determine the roadway circulatory width. A minimum of 2 feet is to be provided between the circulating lane design vehicles' wheel paths and circulatory road

curb lines. A minimum of 3 feet is to be provided between the inner truck apron curb and the wheel path of the design vehicle for truck apron use. Figure 6.9 illustrates how these clearance dimensions are to be measured.



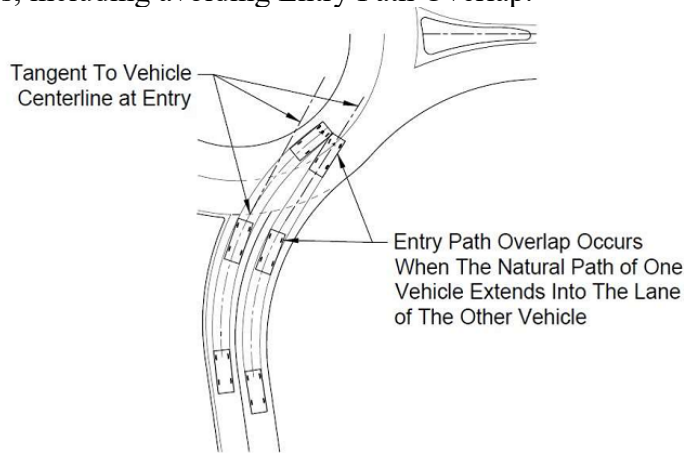
**FIGURE 6.9: DESIGN VEHICLE CURB CLEARANCES**

### 6.2.8.6 CENTRAL ISLAND

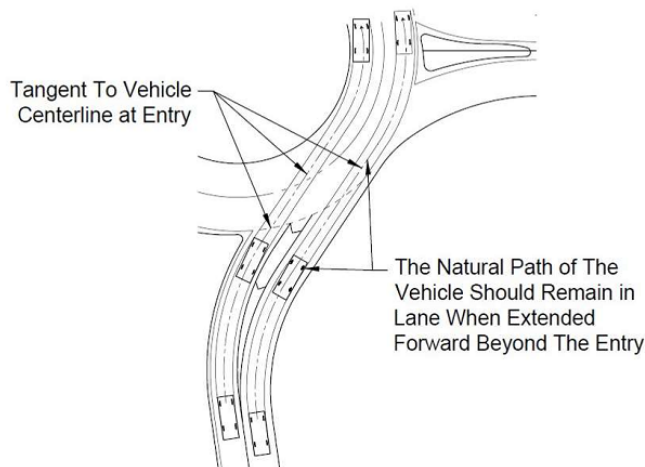
The central island of a roundabout is the raised, mainly non-traversable area surrounded by the circulatory roadway. It may also include a traversable truck apron. The central island shall not contain anything that attracts pedestrians onto the island or that can be a distraction to drivers. Central islands shall be visible to approaching traffic and provide a cue for traffic to slow down and carefully navigate the intersection.

6.2.8.7 ENTRY RADIUS

The entry radius is to be designed curvilinearly tangential to the outside edge of the circulatory roadway. The projection of the left edge of each entry roadway lane is to be curvilinearly tangential to the left lane line of the receiving lane of the circulatory roadway, which may be the central island. A short tangential section or gore area approaching the yield line may be needed to prevent overlapping paths. With multilane roundabouts, the designer is to consider the natural paths of vehicles to ensure the proposed geometry directs vehicles to stay within the proper lanes through the circulatory roadway and exits. Path overlap occurs when the natural paths of vehicles in adjacent lanes overlap or cross one another. The entry design should align vehicles into the appropriate lane within the circulatory roadway, using the technique shown in Figure 6.10 or others that promote good path alignment. See NCHRP Report 672 Section 6.4.5 for additional guidance on entry design for single-lane roundabouts and Section 6.5.4 for guidance on entry design for multi-lane roundabouts, including avoiding Entry Path Overlap.



ENTRY ALIGNMENT WITH PATH OVERLAP  
(Unacceptable)



ENTRY ALIGNMENT WITHOUT PATH OVERLAP  
(Acceptable Entry Alignment)

**FIGURE 6.10: ENTRY PATH ALIGNMENT – AVOID PATH OVERLAP**

### **6.2.8.8 EXIT RADIUS**

The exit curb radius is to be curvilinearly tangential to the outside edge of the circulatory roadway. Guidance on exit design is provided in NCHRP Report 672 Sections 6.4.6 and 6.5.6.

### **6.2.8.9 TRUCK APRON**

Truck aprons are traversable areas provided to accommodate semi-trailer off-tracking while keeping the circulatory roadway width narrow enough to maintain speed control for smaller vehicles.

Truck aprons shall be a different color and texture than the roadway surface. Truck aprons shall be raised above the adjoining roadway using roll curb.

Where truck aprons are used, the slope of the apron shall not exceed two percent.

## **6.2.9 MINI-ROUNABOUTS**

A mini-roundabout is a type of roundabout characterized by a relatively small inscribed circle diameter, fully traversable central island, and splitter islands.

Figures 6-11 and 6-12 illustrate a typical mini-roundabout layout connecting two intersecting local residential streets. Figure 6-11 identifies features and typical standard construction details to be used for mini-roundabout designs and Figure 6-12 demonstrates the magnitude of dimensions that may occur within in a typical geometric layout.

The location and size of a mini-roundabout central island (and the corresponding width of the circulatory roadway) is usually determined by the S-BUS-40 swept path requirements. The off-tracking of vehicles larger than an S-BUS-40 is accommodated by vehicles encroaching onto the footprint of the central island.

Mini-roundabouts differ from neighborhood traffic (calming) circles by having approach splitter islands on all approaches and a traversable central island. Neighborhood traffic circles may be used to create a low-speed environment within residential subdivisions if they will have the same functional characteristics as a roundabout. The approaches must naturally cause counterclockwise circulation around the central island, have yield control at all entries, and accommodate passage of a WB-50 design vehicle.

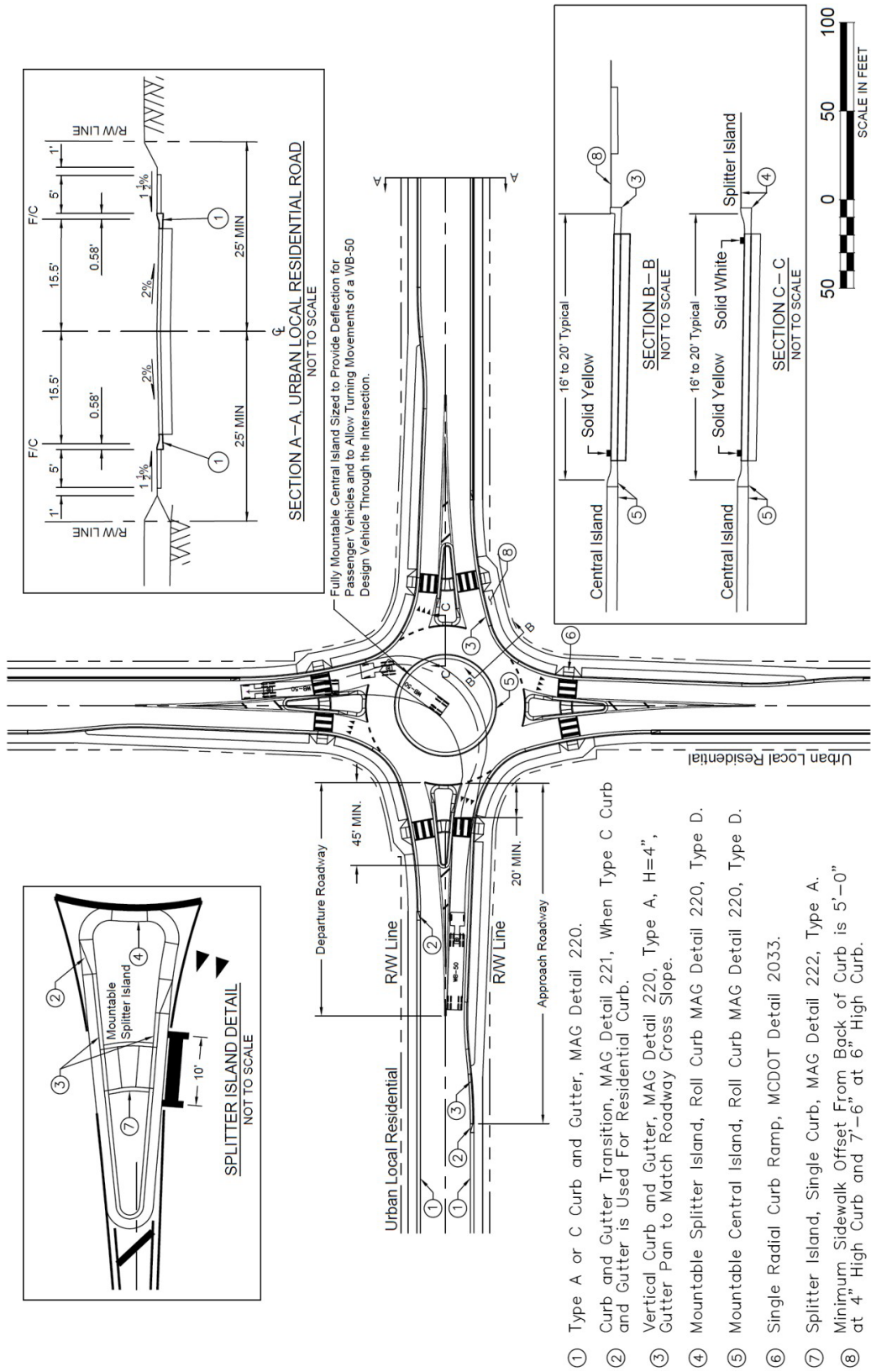


FIGURE 6.11: URBAN MINI-ROUNDAABOUT TYPICAL LAYOUT



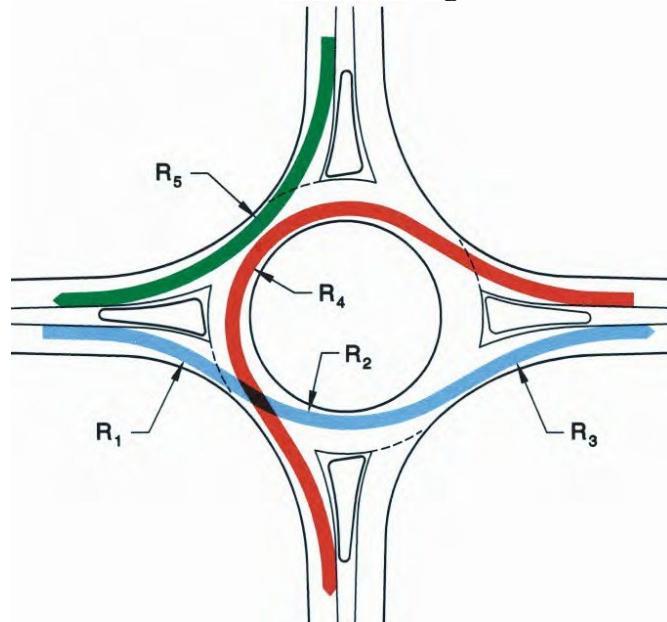
## 6.2.10 PERFORMANCE CHECKS

### DESIGN VEHICLE ACCOMMODATION

Adequacy of the roundabout design to accommodate each permitted movement from each lane of the roundabout by each applicable design vehicle as specified in Table 6.5 is to be determined and documented using appropriate vehicle tracking software. Through and turning movement swept path diagrams for Design Vehicle 1 and for Design Vehicle 2, as each is defined in Figure 6.9 are to be included with every roundabout design submittal. Additional guidance for accommodating the swept path of vehicles is provided in NCHRP Report 672 Sections 6.4.7 and 6.5.7.

### FASTEST PATH

The fastest path is the smoothest, flattest path possible for a single vehicle, a passenger car (P), in the absence of other traffic and ignoring all lane markings, to travel through the entry, around the central island, and out the relevant exit. Figure 6.13 identifies and illustrates the five critical path radii that comprise the fastest path for each permitted movement through the roundabout. These radii consist of R1 – the Entry Path radius, R2 – the Circulating Path Radius, R3 – the Exit Path Radius, R4 – the Left Turn Path Radius, and R5 – the Right Turn Path Radius.

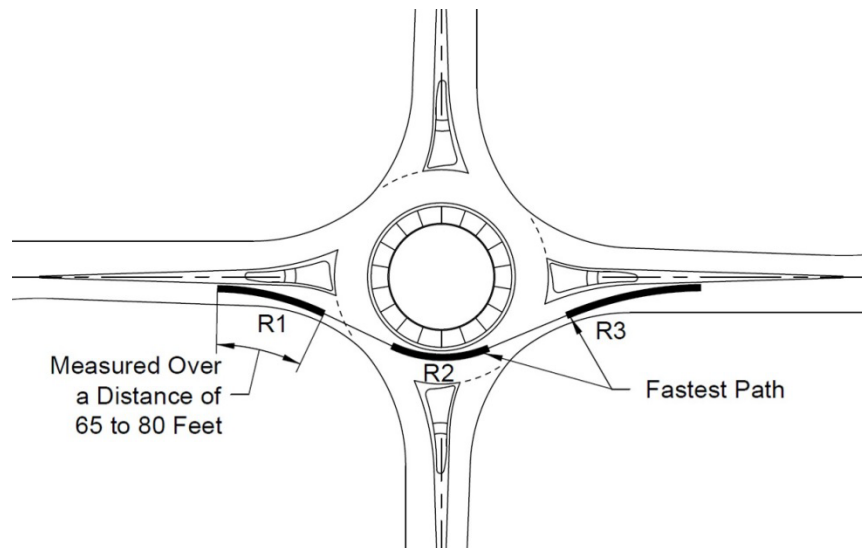


**FIGURE 6.13: VEHICLE PATH RADII**

Source: NCHRP Exhibit 6-47

The ability for a specific geometric configuration to achieve the speed management objective is determined through a process which involves drawing, measuring the radii, and computing (or pulling from a radius-speed relationship table) fastest path speeds for all movements and comparing the results against applicable design criteria. Scaled and sealed drawing documenting fastest paths for all approaches and all movements are to be included within the design documentation to be submitted with every roundabout plan review submittal. Fast path movements include all left turn movements, all right turn movements, and all through movements. Section 6.7.1 of NCHRP Report 672 provides detailed instructions for one acceptable method for graphically constructing the fastest vehicle paths for all critical movements at a roundabout. Another acceptable method applied to a minor collector-local residential roundabout drawing is

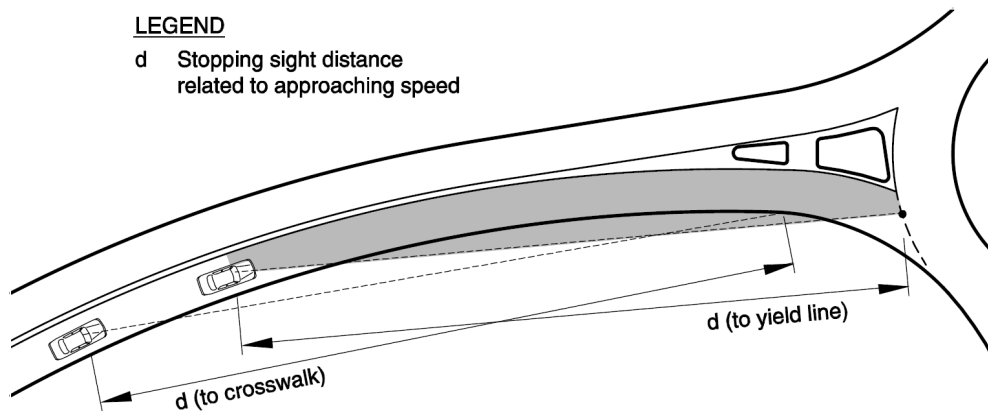
shown in Figure 6.14. As many schematics as needed to show all fastest paths clearly shall be produced and submitted. A table that lists the radii of the component curves of each fastest path and the corresponding design speed for the curve is to accompany the fast path drawings.



**FIGURE 6.14: FASTEST PATH EXHIBIT**

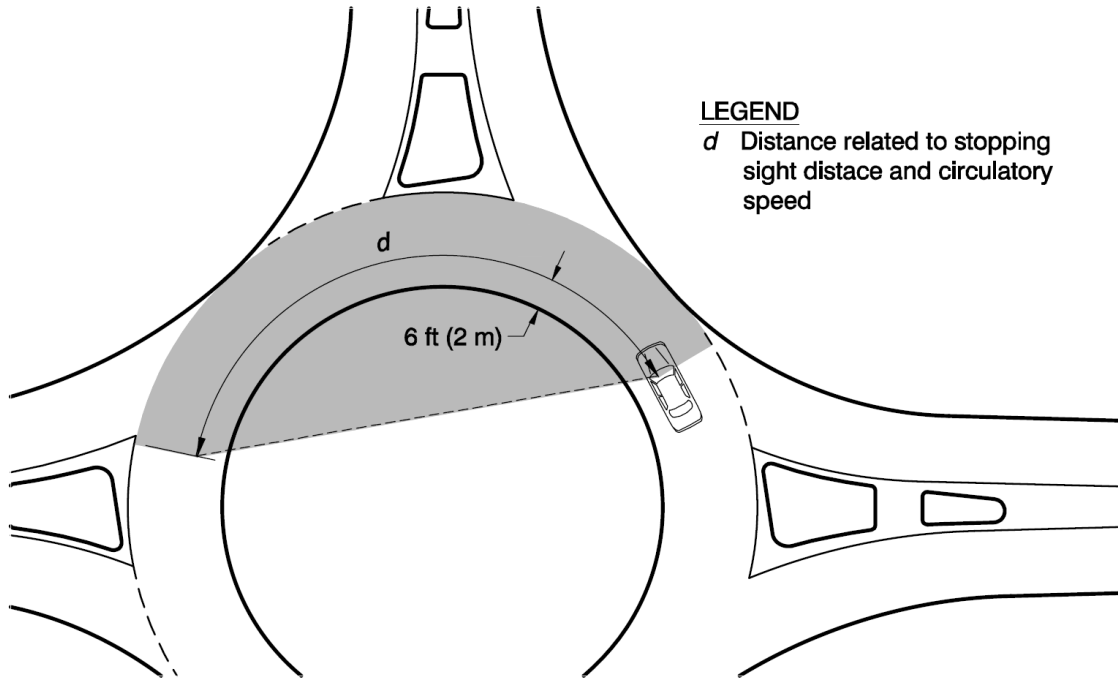
**STOPPING SIGHT DISTANCE**

Adequate stopping sight distance must be provided on the roundabout approaches, within the roundabout circulatory roadway, and to the crosswalks on the exits. Approaching driver sight distance is illustrated in Figure 6.15, circulating driver stopping sight distance is illustrated in Figure 6.16, and exiting driver stopping sight distance is shown in Figure 6.17. Anticipated sight distance through the roundabout can be measured using speed-radius relationship information provided in NCHRP Report 672 Exhibit 6-52, and stopping sight distance criteria provided in Section 5.15 of this Manual.



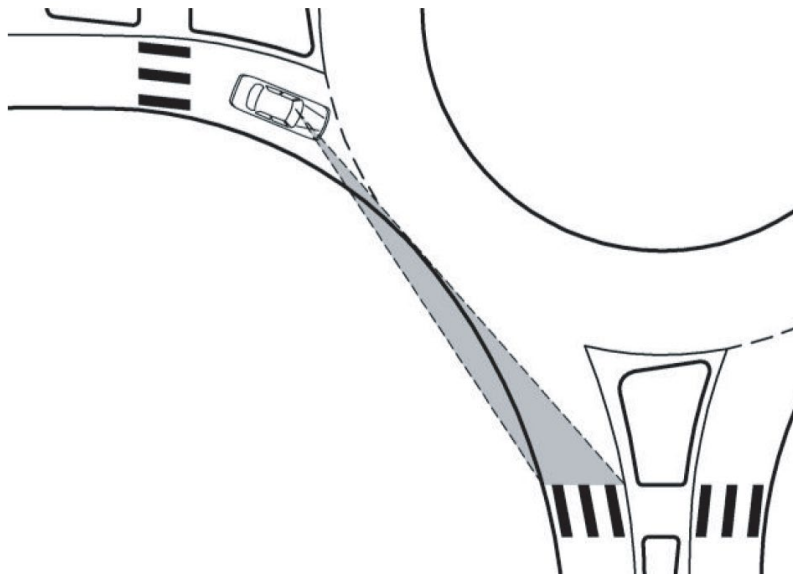
**FIGURE 6.15: STOPPING SIGHT DISTANCE ON APPROACH**

Source: NCHRP Report 672 Exhibit 6-55



**FIGURE 6.16: STOPPING SIGHT DISTANCE ALONG CIRCULATING ROADWAY**

Source: NCHRP Report 672 Exhibit 6-56

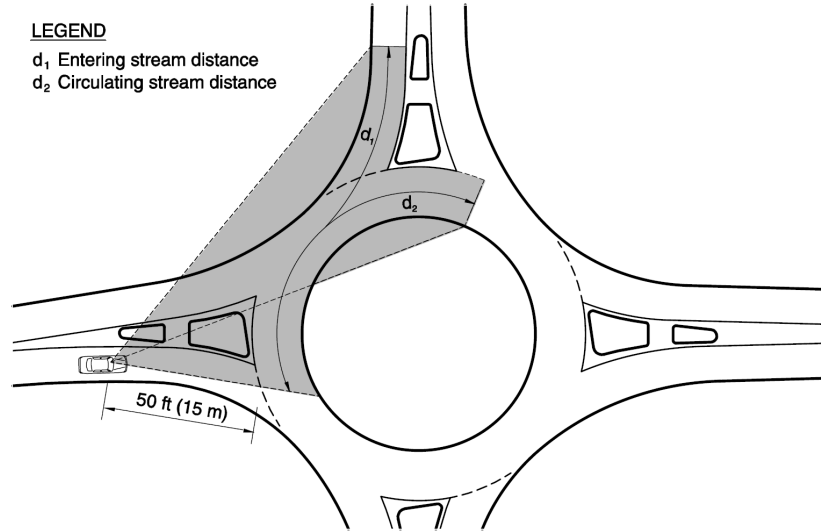


**FIGURE 6.17: STOPPING SIGHT DISTANCE TO CROSSWALK ON EXIT**

Source: NCHRP Report 672 Exhibit 6-57

### INTERSECTION SIGHT DISTANCE

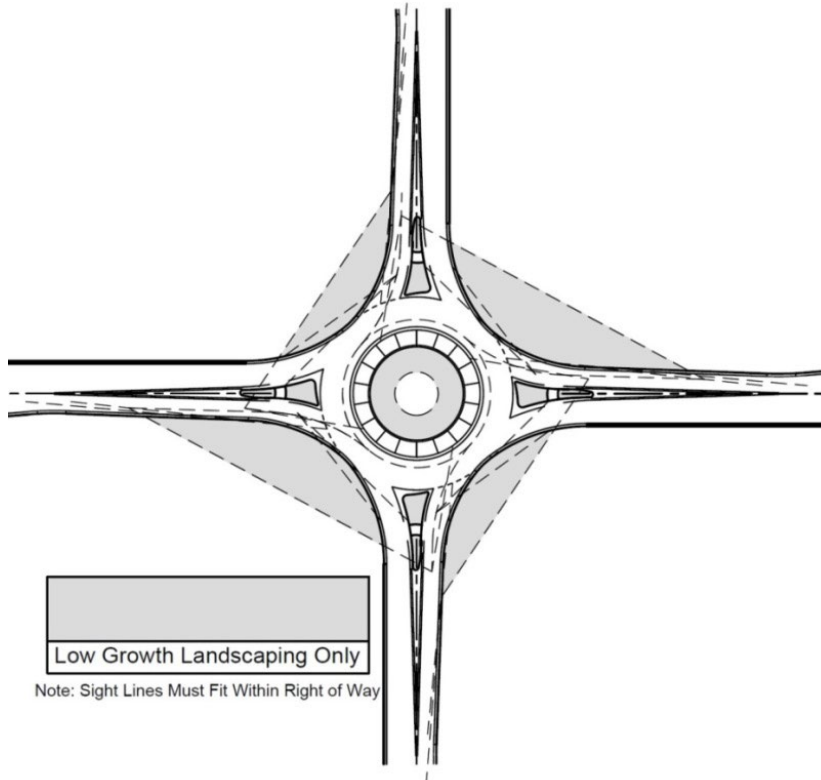
Adequate intersection sight distance (sight triangle) is to be provided for approaching traffic on the circulating roadway and on other approach legs to enable the motorist to determine when to enter the roundabout. Figure 6.18 illustrates this concept.



**FIGURE 6.18: INTERSECTION SIGHT DISTANCE**

Source: NCHRP Report 672 Exhibit 6-58

All roundabout design submittals are to include sight distance diagrams consistent with those presented in Figures 6.15 through 6.18 to cover all approaches and circulating segments of the roundabout, as well as a fully dimensioned composite sight distance diagram for use in defining height restrictions for landscaping and other vertical design features within and near the roundabout. Graphic elements of a composite sight distance diagram are presented in Figure 6.19. Sight distance composite diagrams included with design submittals shall be fully dimensioned.



**FIGURE 6.19: COMPOSITE SIGHT DISTANCE DIAGRAM (PRIOR TO DIMENSIONING)**

## 6.2.11 VERTICAL CONSIDERATIONS

### CROSS SLOPE

The circulating roadway should be designed with a constant slope toward the outside of the roundabout within the range of 1.5% to 2.0%.

Splitter island areas are to have positive drainage, roadways are to have a minimum of 1.0% cross slope and the longitudinal grade shall not exceed 2%. The pedestrian crossing shall be ADA compliant.

### CURBING

Roundabout approach and departure roadways shall have vertical curb. The right side of the approach roadway shall have vertical curb throughout the approach deceleration zone. The right side of the departure roadway shall have vertical curb throughout the curbed length of the splitter island. The entire length of the splitter island shall use vertical curb, except on local residential street for mini-roundabouts where splitter islands may need to be traversable to accommodate a WB-50 design vehicle.

The outer curb line of the circulating roadway connecting the approach and departure roadways is to be vertical curb and gutter with a curb height equal to the highest curb height of the connected curb lines.

The central island exterior curb (adjacent to circulating roadway) shall be roll curbing (MAG Detail 220, Type D).

Six inch (6") high vertical curb shall be used for the truck apron's interior curb located along the perimeter of the non-traversable portion of the central island.

The pedestrian walkway through the splitter island shall have along each side vertical curb matching the height of the splitter island curbing.

### DRAINAGE

Drainage structures when needed should be placed upstream from crosswalks, placement within the entry and exit radii or within the circulatory roadway should be avoided. A primary concern with having inlets located within or adjacent to the circulatory roadway are traffic restrictions required during maintenance operations.

### GEOMETRIC LAYOUT CONTROL

The use of construction centerline Stations and Offsets to define curb line geometry for roundabouts shall be supplemented or replaced by curve data along the face of curb. Curve data shall consist of radius (R), tangent length (T), central angle delta ( $\Delta$ ), and arc length (L). As a minimum, curve data shall be provided along all roundabout exterior curb lines from the Entry Radius curve through the Exit Radius curve and construction centerline stations and offsets shall be provided at the beginning of the Entry Radius curve and at the end of the Exit Radius curve.

## ELEVATION CONTROL

Elevation control is to be provided at each curb PC, PT, PRC, and PCC. For the central island curbing (exterior curb and inside truck apron curb) the elevation control points are to include points located by the intersection of the construction centerline extension of each roundabout leg and also along the angle that bisects the centerline extensions of the roundabout legs where the bisecting line intersect the central island exterior curb and the outer curb line of the circulatory roadway. An example of the application of this guidance is presented in Figure 6.20.

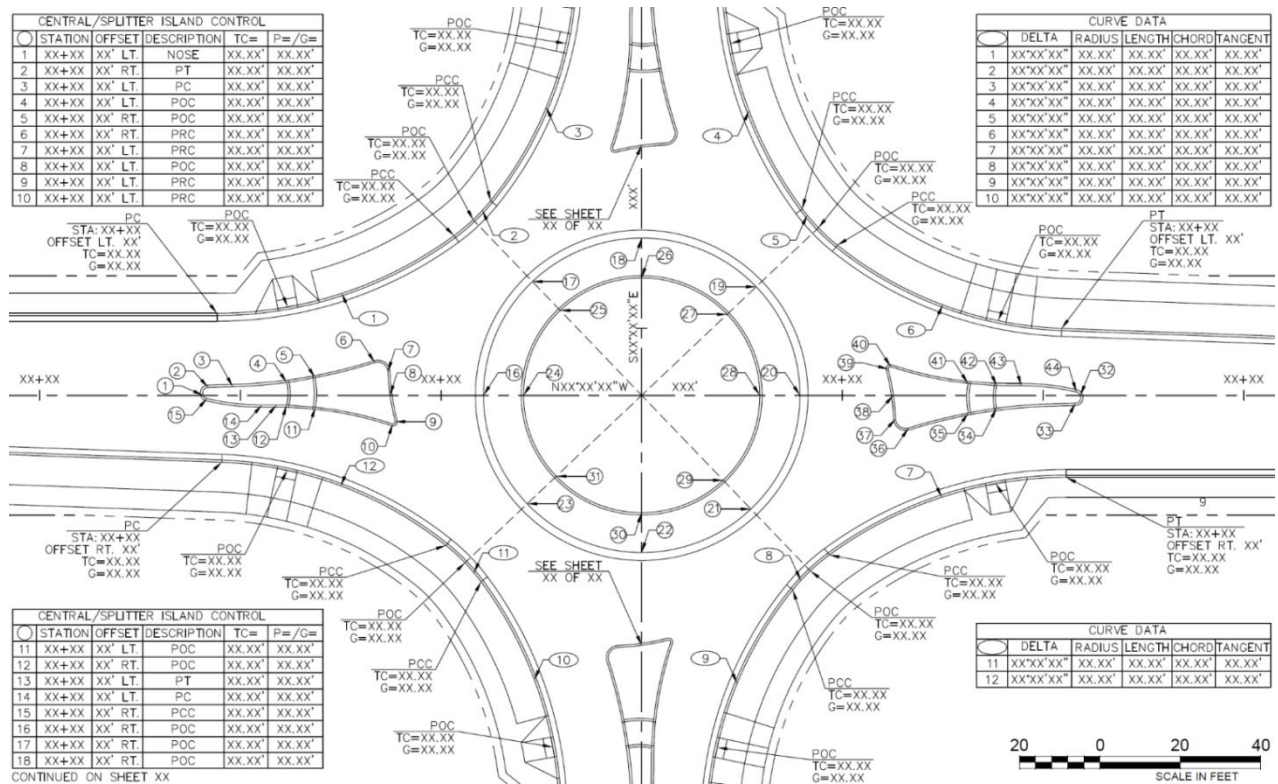


FIGURE 6.20: ELEVATION CONTROL REQUIREMENTS

### 6.2.12 OTHER DESIGN DETAILS

#### PEDESTRIANS AND BICYCLISTS

Sidewalks shall be provided on all roundabout approaches that connect to existing or planned pedestrian facilities, or where there is anticipated pedestrian demand based on proposed development and/or adjacent land use. Crosswalks and refuge areas shall be provided to connect all roundabout approaches that have sidewalks or mixed use paths. A buffer shall be provided between roadway curb and the sidewalk. See Figures 6.5, 6.6 and 6.13 for sidewalk setback requirements which vary based on adjacent curb height.

Where bicycle lanes are used on approach roadways to multilane roundabouts, optional use bicycle ramps shall be provided to allow bicyclists to use the sidewalk or other adjacent pathway to negotiate the roundabout. Where optional use bicycle ramps are provided, the sidewalk width

through the roundabout shall be increased by a minimum of three feet (3'). Between the bicycle street exit and entrance ramps, the minimum sidewalk width through roundabouts shall be eight feet (8'). The bottom width of curb ramps located along widened portions of walkways shall match the full width of the widened walkway. Optional use bike ramps may be required at urban single-lane roundabouts where high traffic volumes are anticipated. Further information for the design of bicycle accommodations for roundabouts is provided in NCHRP Report 672, Section 6.8.2.

# **Chapter 7**

## **Access to Maricopa County Roadway System**

TABLE OF CONTENTS

CHAPTER 7 ACCESS TO MARICOPA COUNTY ROADWAY SYSTEM

**7.1 ACCESS CONTROL..... 7-1**  
 7.1.1 GENERAL..... 7-1  
 7.1.2 ACCESS TO STATE HIGHWAYS..... 7-1  
 7.1.3 ACCESS TO CITY OR TOWN STREETS ..... 7-1  
 7.1.4 ACCESS TO COUNTY ROADS..... 7-1

**7.5 DRIVEWAYS..... 7-3**  
 7.5.1 DEFINITION..... 7-3  
 7.5.2 DRIVEWAY TYPES..... 7-3  
 7.5.3 SURFACE REQUIREMENTS FOR DRIVEWAY AND ROADWAY  
 CONNECTIONS..... 7-3

**7.6 DRIVEWAY CHARACTERISTICS..... 7-5**  
 7.6.1 SINGLE FAMILY RESIDENTIAL ..... 7-5  
 7.6.2 MULTI-FAMILY RESIDENTIAL ..... 7-5  
 7.6.3 COMMERCIAL AND INDUSTRIAL DRIVEWAYS..... 7-6  
 7.6.4 PRIVATE ROADS ..... 7-6

**7.7 DRIVEWAY DESIGN..... 7-8**  
 7.7.1 RESTRICTION OF TURNING MOVEMENTS ..... 7-8  
 7.7.2 ISLANDS FOR LIMITED MOVEMENT ACCESSES..... 7-8  
 7.7.3 RADII AND WIDTHS ..... 7-10  
 7.7.4 RELOCATION OF UTILITIES, STRUCTURES, AND TREES ..... 7-10  
 7.7.5 DRIVEWAY SIGHT DISTANCE ..... 7-10  
 7.7.6 DRIVEWAY PROFILES ..... 7-11  
 7.7.7 DRIVEWAY TYPICAL SECTIONS..... 7-13  
 7.7.8 DRIVEWAY ANGLES..... 7-13  
 7.7.9 DRAINAGE..... 7-13

**7.8 NUMBER OF DRIVEWAYS ..... 7-14**  
 7.8.1 ADDITIONAL DRIVEWAYS..... 7-14  
 7.8.2 TEMPORARY ACCESS..... 7-14  
 7.8.3 LARGE DEVELOPMENTS ..... 7-14

**7.9 DRIVEWAY LOCATIONS..... 7-15**  
 7.9.1 DRIVEWAY LOCATION COORDINATION..... 7-15  
 7.9.2 DRIVEWAY SPACING..... 7-15  
 7.9.3 JOINT ACCESS ..... 7-15  
 7.9.4 DRIVEWAY CORNER CLEARANCE FOR ARTERIAL AND  
 COLLECTOR ROADS..... 7-16  
 7.9.5 DRIVEWAY LOCATION RESTRICTIONS ..... 7-17  
 7.9.6 VARIANCES..... 7-17

<b>7.10</b>	<b>DRIVEWAY STORAGE .....</b>	<b>7-18</b>
<b>7.15</b>	<b>AUXILIARY LANES FOR DRIVEWAYS.....</b>	<b>7-20</b>
	7.15.1 RIGHT TURN LANE WARRANTS .....	7-20
	7.15.2 LEFT TURN LANE WARRANTS .....	7-20
	7.15.3 ACCELERATION LANES .....	7-21
	7.15.4 GENERAL SPEED CHANGE, LANE CRITERIA .....	7-22

**LIST OF FIGURES**

FIGURE 7.1 – RIGHT-IN, RIGHT-OUT, LEFT-OUT ACCESS .....	7-9
FIGURE 7.2 – RIGHT-IN, RIGHT-OUT, LEFT-IN ACCESS DESIGN.....	7-9
FIGURE 7.3 – RIGHT-IN, RIGHT-OUT, RIGHT-OUT ACCESS DESIGN.....	7-10
FIGURE 7.4 - RURAL DRIVEWAY GRADES .....	7-12
FIGURE 7.5 - URBAN DRIVEWAY GRADES .....	7-12
FIGURE 7.6 – MINIMUM CORNER CLEARANCES (SIGNALIZED INTERSECTION) ..	7-16
FIGURE 7.7 – RIGHT-TURN ACCELERATION LANES .....	7-21

**LIST OF TABLES**

TABLE 7.1: SURFACE REQUIREMENTS FOR DRIVEWAY CONNECTIONS.....	7-4
TABLE 7.2: VEHICLE TYPE FOR DETERMINING DEPARTURE SIGHT TRIANGLES	7-11
TABLE 7.3: DRIVEWAY % GRADE CHANGES WITHOUT A VERTICAL CURVE.....	7-13
TABLE 7.4: MINIMUM CORNER CLEARANCES (SIGNALIZED INTERSECTIONS)....	7-16
TABLE 7.5: VEHICLE STORAGE REQUIREMENTS .....	7-18
TABLE 7.6: VOLUME WARRANTS FOR RIGHT-TURN LANES.....	7-20
TABLE 7.7: VOLUME WARRANTS FOR LEFT-TURN LANES .....	7-21

## **7.1 ACCESS CONTROL**

### **Originator: Transportation Systems Management & Operations Division**

#### **7.1.1 GENERAL**

The efficiency and safety of a street or highway depends largely on the number and character of interferences affecting vehicles moving along the facility. Major interferences are caused by vehicles entering, leaving, or crossing the road, at intersecting streets and driveways. In order to minimize crashes and to assure best overall use of the facility by the general public, it is necessary to regulate vehicle movements in and out of abutting developments and cross streets.

With respect to driveways, road users have certain rights of access to abutting property as well as the right to travel on the road with relative safety and freedom from interference. Since these various rights sometimes conflict, the County is given the responsibility for reconciling and satisfying, to the extent feasible, the needs and rights of all road users with respect to driveway location, design, and operation. **When conflicts arise, preference will be given to the safe and efficient use of the road.**

Existing accesses, even if not in use, must not be relocated, altered, or reconstructed without a permit and approval from MCDOT. When an access to a roadway with a curb and gutter is abandoned, it is to be replaced by a full height curb across the abandoned access and the depression behind the curb is to be filled. When an access to a roadway with a shoulder and ditch is abandoned, it is to be removed and the area graded to match the existing shoulder and ditch.

#### **7.1.2 ACCESS TO STATE HIGHWAYS**

Access to State highways is regulated by the Arizona Department of Transportation (ADOT). Maricopa County will not review changes to an existing access or any new access which is in State right-of-way. Encroachment permits for access to State highways must be obtained directly from ADOT. The County shall review requests for new access where any portion of the access is in County right-of-way.

#### **7.1.3 ACCESS TO CITY OR TOWN STREETS**

Accesses to streets of cities or towns are regulated by the appropriate city or town. Maricopa County will not review any changes to an existing access or any new access to a street which is in a city's or town's right-of-way. Encroachment permits for access to streets must be obtained directly from the city or town. MCDOT shall review a request for new accesses where any portion of the access is in County right-of-way.

#### **7.1.4 ACCESS TO COUNTY ROADS**

All construction to create, modify, or remove a driveway connection to a County road must first be authorized by a valid MCDOT Permit.

In general, a Traffic Impact Study (TIS) shall be required of all developments, or additions to existing developments, generating 100 or more trips during the morning or afternoon peak hours on the adjacent street. For developments generating less than 100 peak hour trips, a Traffic Statement (TS) may be required. The criteria for submitting a TIS or TS is described in the MCDOT Traffic Impact Study Manual.

A change in the use of any property may necessitate a change in its access. To ensure safe and efficient operation of both the roadway and driveway accesses, a review of the access needs (locations and design) of existing facilities is required when the character of a facility's function changes. Changes in the number and location of access points together with a design for each access point shall be submitted to MCDOT for approval.

A Traffic Impact Study (TIS) may be required for a property when there is a change in use or zoning; or when property is combined or subdivided.

Modifications in advertising, landscaping, general maintenance, or aesthetics that do not affect internal or external traffic flow or safety do not require a new driveway permit.

## **7.5 DRIVEWAYS**

### **Originator: Transportation Systems Management & Operations Division**

#### **7.5.1 DEFINITION**

A driveway is any access constructed within the public right-of-way, connecting the public roadway with adjacent property or properties.

**Driveways are private facilities constructed under permit within public right of way. The facility owner, not the County is responsible for maintenance and repair of driveway pavements, driveway culverts, and driveway embankment slopes.**

The principles of intersection design apply directly to driveways. One important feature of a driveway is controlling the location for accessing the road by the elimination of large graded or paved areas adjacent to the traveled way that allow drivers to enter or leave the street randomly.

#### **7.5.2 DRIVEWAY TYPES**

- a. Single Family Residential: A driveway that provides access to a single family residence or lot.
- b. Multi-Family Residential: A driveway that provides access to a duplex or an apartment building that serves 2 to 50 dwelling units.
- c. Commercial: A commercial driveway is one providing access to an office, retail, or institutional building or complex, or to an apartment building having more than 50 dwelling units.
- d. Industrial: An industrial driveway is one directly serving truck movements.
- e. Private Road: A driveway that provides, or has the capability of providing, access to more than one (1) single family residence or lot; or development site.

See Section 7.6 for additional information.

#### **7.5.3 SURFACE REQUIREMENTS FOR DRIVEWAY AND ROADWAY CONNECTIONS**

All new driveways and all new roadway connections to a paved County road shall be paved within the County right-of-way. “Paved” includes asphaltic concrete, Portland cement concrete, and other materials approved by the MCDOT Director or authorized representative.

New construction that widens a roadway or converts an unpaved roadway into a paved roadway shall also pave existing driveway connections located within the project limits in compliance with Table 7.1.

<b>TABLE 7.1: SURFACE REQUIREMENTS FOR DRIVEWAY CONNECTIONS</b>		
<b>Roadway Edge</b>	<b>Existing Driveway Conditions</b>	<b>Driveway Surface Materials</b>
Uncurbed	Concrete, asphalt, or hard surfaced custom decorative driveway within 5' of the R/W	Asphalt Paved Turnout (MAG Detail 205) connecting to the existing driveway surfacing.
Uncurbed	Earthen or gravel driveway within and 5' beyond the R/W	If an acceptable vertical profile can be obtained within the R/W then provide: Asphalt Paved Turnout (MAG Detail 205) to within 5' of the R/W and provide a graded transition of ABC or existing gravel between the Paved Turnout and R/W. If an acceptable vertical profile needs to extend beyond the R/W then provide: Asphalt Paved Turnout (MAG Detail 205) to the R/W; beyond the R/W provide ABC surfacing to the match point with the existing driveway.
Concrete Curb	Concrete Driveway within 5' of the R/W	Concrete driveway entrance (MCDOT Detail 2050) plus concrete driveway pavement to connect with the existing driveway.
Concrete Curb	Asphalt Driveway within 5' of the R/W	Concrete driveway entrance (MCDOT Detail 2050) plus asphalt driveway pavement to connect with the existing driveway.
Concrete Curb	Gravel surfaced driveway within 5' of the R/W	Concrete driveway entrance (MCDOT Detail 2050) plus asphalt driveway pavement between the driveway entrance and the existing driveway.
Concrete Curb	Earthen driveway within and 5' beyond the R/W	Concrete driveway entrance (MCDOT Detail 2050) plus asphalt driveway pavement between the driveway entrance and the existing driveway surface.
Concrete Curb	Decorative Custom Driveway within 5' of the R/W	Concrete driveway entrance (MCDOT Detail 2050) and coordinate the material with the property owner. County supplied and installed options are asphalt or Portland cement concrete pavement.
<p>Note: 1.) Construction outside of the right of way requires a temporary construction easement (TCE). If a TCE is not granted, work shall be limited to within the right of way. 2.) Return Type Driveway (MCDOT Detail 2036) to be used only upon approval of the MCDOT Director or authorized representative.</p>		

## **7.6 DRIVEWAY CHARACTERISTICS**

### **Originator: Transportation Systems Management & Operations Division**

#### **7.6.1 SINGLE FAMILY RESIDENTIAL**

Driveways serving a single family residence shall have a minimum width of 12 feet and a maximum width of 24 feet within County right of way. For garages located within 25 feet of the right-of-way line, the driveway width may equal the width of the garage opening.

Driveway connections to uncurbed roadways shall use perpendicular paved turnouts (MAG Detail 205 - Type A, B, or C) with flared connections. Flared connections may be 45° triangles or radial fillets. Asphalt pavement for driveways shall be a minimum 2.5" of asphalt concrete over 6" of aggregate base within County right of way. Concrete or other paving materials may be used with MCDOT approval. When approved by MCDOT, concrete driveway pavement shall be at least MAG Class B and a minimum of 5" thick.

Driveway connections to vertical curbed roadways shall use a concrete depressed curb driveway entrance (MCDOT Detail 2050) having a minimum entrance width of 16 feet and a maximum width of 30 feet. The driveway centerline must match the centerline of the driveway entrance.

Driveway connections to roadways with ribbon, roll, or mountable curbs may have, but are not required to have, driveway widening at the back of the curb connection.

Driveways connecting to arterial or major collector streets shall include adequate turnaround space on the private property, or a circular driveway, to eliminate the need to back a vehicle onto the roadway. Driveway plans must be approved by the MCDOT Transportation Systems Management & Operations Division.

#### **7.6.2 MULTI-FAMILY RESIDENTIAL**

Driveways serving multi-family developments are to have 24 foot wide driveways with widening at the street connection. Driveways serving 2 to 50 dwelling units shall be designed in accordance with these guidelines. Driveways serving multi-family developments of more than 50 dwelling units shall be designed as commercial driveways in accordance with Section 7.6.3.

Driveway connections to uncurbed roadways shall use perpendicular paved turnouts (MAG Detail 205 - Type A, B, or C) with flared connections. Flared connections may be 45° triangles or radial fillets. Asphalt pavement for driveways shall be a minimum 2.5" of asphalt concrete over 6" of aggregate base within County right of way. Concrete or other paving materials may be used with MCDOT approval. When approved by MCDOT, concrete driveway pavement shall be at least MAG Class B and a minimum of 5" thick.

Driveways connecting to local or minor collector roadways with vertical curbing shall use a 30 foot wide concrete depressed curb driveway entrance (MCDOT Detail 2050). The driveway

centerline shall match the centerline of the driveway entrance, and a 5:1 taper rate shall be used to match from the driveway entrance width to the driveway width.

Driveway connections to a major collector or arterial street with vertical curbing shall use a concrete depressed curb driveway entrance (MCDOT Detail 2050). A return type driveway (MCDOT Detail 2036) may be used if approved by the MCDOT Director or authorized representative. The concrete depressed curb driveway entrance shall be 36 feet wide. The driveway centerline shall match the centerline of the driveway entrance, and a 5:1 taper rate shall be used to transition from the driveway entrance width to the driveway width. A return type driveway shall be 30 feet wide with a minimum return radii of 6 feet. MCDOT may require driveways to be widened to 40 feet to provide for a separate left turn lane.

### **7.6.3 COMMERCIAL AND INDUSTRIAL DRIVEWAYS**

A commercial driveway provides access to an office, retail, or institutional building complex, or to an apartment building having more than 50 dwelling units. Such developments are customarily served by trucks as an incidental rather than a principal driveway use. Industrial plant driveways whose principal function is to serve administrative or employee parking lots are also considered commercial driveways.

An industrial driveway is one directly serving substantial numbers of truck movements to and from an industrial facility, warehouse, or truck terminal. A centralized retail development, such as a community or regional shopping center, may have one or more driveways specially designed, signed, and located to provide access for trucks. These are also classified as industrial driveways.

Driveways serving commercial and industrial developments shall be designed based on the types and volumes of vehicles anticipated to use the driveway, along with the traffic volumes, number of lanes, and operating speed of the connecting County roadway. Driveway connections to an urban roadway with vertical curbs shall use a concrete depressed curb driveway entrance (MCDOT Detail 2050) or a return type driveway (MCDOT Detail 2036). Depressed curb driveway entrances are standard for curbed roadways. Return type driveways may be used for high volume driveways with the approval of the MCDOT Director or authorized representative.

The maximum depressed curb driveway entrance width is 40 feet. The concrete depressed curb driveway entrance will be wider than the required driveway lane widths to facilitate off tracking of turning vehicles. A 5:1 or flatter taper rate shall be used to transition from the driveway entrance width to the driveway width.

Return type driveways are generally restricted to high volume facilities. The return radii and lane widening requirements are adjusted to accommodate off tracking of turning vehicles.

Driveway connections to uncurbed roadways shall be asphalt paved turnouts (MAG Detail 205 Type A, B, or C). The turnout design shall contain vehicle off tracking on the pavement for all vehicles types anticipated to use the driveway.

### **7.6.4 PRIVATE ROADS**

A private road is any roadway that carries traffic, that may or may not be contained within an easement or dedicated right-of-way, but that is not owned or maintained by a governmental entity.

The design of private road connections to the County road system shall be based on roadway vehicle mix and volumes. Very low-volume private road connections to County roadways shall be designed as Commercial or Industrial driveways. Private roads with higher traffic volumes that would connect to County roadways shall be designed in accordance with the requirements of Chapter 6 Intersections. Intersection design shall comply with design requirements of a roadway classification acceptable to the MCDOT Traffic Engineer.

A private road may be within an access easement or patent easement that serves or will serve more than one lot. Private road connections that would provide access to a County roadway for more than one property shall be designed as a Joint Access as described in Section 7.9.3. Parcels adjoining the private road shall access the County road system via the private road, and will not be provided access directly to the County road system without the approval of the MCDOT Director or authorized representative.

The ultimate improvements associated with the private road connection with the MCDOT roadway shall be required to be constructed concurrent with the development/improvement to be constructed with the issued building permit that has frontage along the County right-of-way. The minimum width of private road connections within County right-of-way shall be 24 feet.

## **7.7 DRIVEWAY DESIGN**

### **Originator: Transportation Systems Management & Operations Division**

#### **7.7.1 RESTRICTION OF TURNING MOVEMENTS**

Where necessary for the safe and efficient movement of traffic, MCDOT may require access points to be geometrically designed so as to provide for only limited turning movements. The restriction of turning movements should not affect the number and location of access points as specified elsewhere.

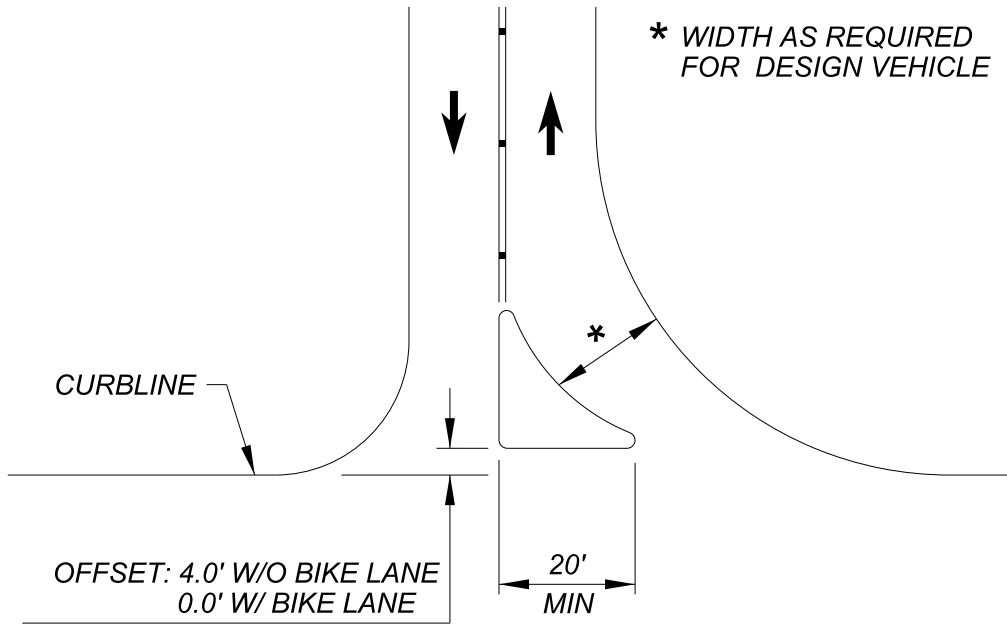
A full access driveway (proposed, new, or change to existing) that causes the LOS to be less than D for any movement may be restricted to a right in/right out access only.

#### **7.7.2 ISLANDS FOR LIMITED MOVEMENT ACCESSES**

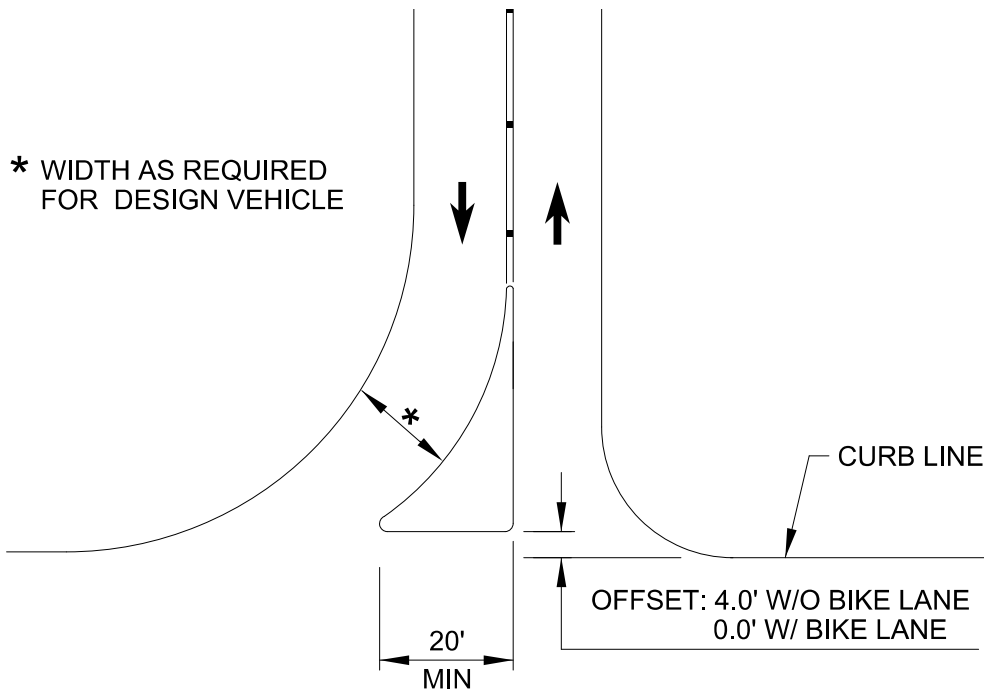
Figures 7.1 - 7.3 illustrate configurations for limited movement accesses. Islands are to be designed with vertical curbs and are to accommodate the turning path of a WB-50 design vehicle. The ends of the islands should typically be provided with 2-foot back of curb radii. Deceleration or acceleration lanes may be required to be incorporated into the design. Reference the AASHTO publication *A Policy on Geometric Design of Highways and Streets* for channelizing island design details.

MCDOT may permit or require the installation of a center median on the adjacent public street as an alternative to driveway islands.

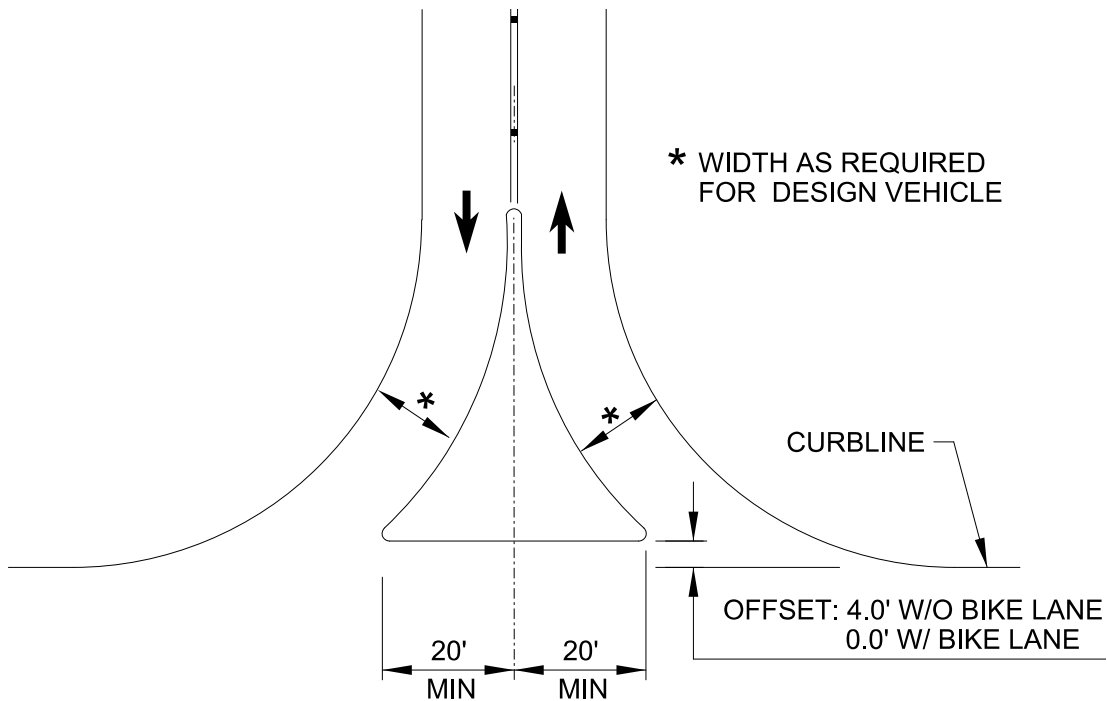
An ADA compliant pedestrian access route shall be provided across the driveway and be contained within the public right-of-way.



**FIGURE 7.1 – RIGHT-IN, RIGHT-OUT, LEFT-OUT ACCESS**



**FIGURE 7.2 – RIGHT-IN, RIGHT-OUT, LEFT-IN ACCESS DESIGN**



**FIGURE 7.3 – RIGHT-IN, RIGHT-OUT, RIGHT-OUT ACCESS DESIGN**

**7.7.3 RADII AND WIDTHS**

Section 7.6 identifies characteristics to be included in the design of driveways. Where customized driveways are required, vertical curb returns will be allowed and/or required by MCDOT. Customized driveways will be required wherever islands to control turning movements are required.

The design of multifamily, commercial, and industrial driveways are to be checked using an appropriate design vehicle turning template to ensure vehicle off-tracking is contained on driveway pavement. Drainage impacts are to be taken into consideration in the design of driveway accesses.

**7.7.4 RELOCATION OF UTILITIES, STRUCTURES, AND TREES**

Prior to commencing any work, arrangements for the necessary removal or relocation of any public utilities, structures, trees, or plantings must be made by the developer or permittee with the person or persons having ownership or control thereof. Removal and relocations shall be accomplished at no expense to the County. All relocations shall be in accordance with MCDOT standards.

**7.7.5 DRIVEWAY SIGHT DISTANCE**

Departure sight triangles shall be determined for driveways using the same procedure as required in Chapter 6 INTERSECTIONS except the speed used to determine the departure sight triangle shall be as indicated in the following table.

Road Classification	Speed for Departure Sight Triangle Calculations	Set-Back from Edge of Road
Local	Posted Speed +5 mph	14.5'
Collector	Posted Speed +5 mph	14.5'
Arterial	Posted Speed +10 mph	18.0'

Driveway sight distance shall be calculated using the time gap for the vehicle type indicated in Table 7.2.

<b>TABLE 7.2: VEHICLE TYPE FOR DETERMINING DEPARTURE SIGHT TRIANGLES</b>			
<b>Major Road Classification</b>	<b>Minor Road Driveway Type</b>	<b>Vehicle 1</b>	
		<b>Right Turn</b>	<b>Left Turn</b>
Arterial	Commercial Industrial	Combination Truck	Combination Truck
Arterial	Residential	Passenger Car	Passenger Car
Collector	Commercial Industrial	Single Unit Truck	Single Unit Truck
Collector	Residential	Passenger Car	Passenger Car
Local	Commercial Industrial	Single Unit Truck	Single Unit Truck
Local	Residential	Passenger Car	Passenger Car

Driveway locations are to be evaluated to determine whether a sight obstruction exists, such as buildings, fences, signs, vegetation, parked vehicles, horizontal or vertical highway alignments, etc. The sight distance requirements for passenger cars are based on a 3.5 foot eye height and a 3.5 foot object height. The distances for trucks are based on a 7.6 foot eye height and a 3.5 foot object height.

If the sight distance is not adequate, consideration should be given to the following options:

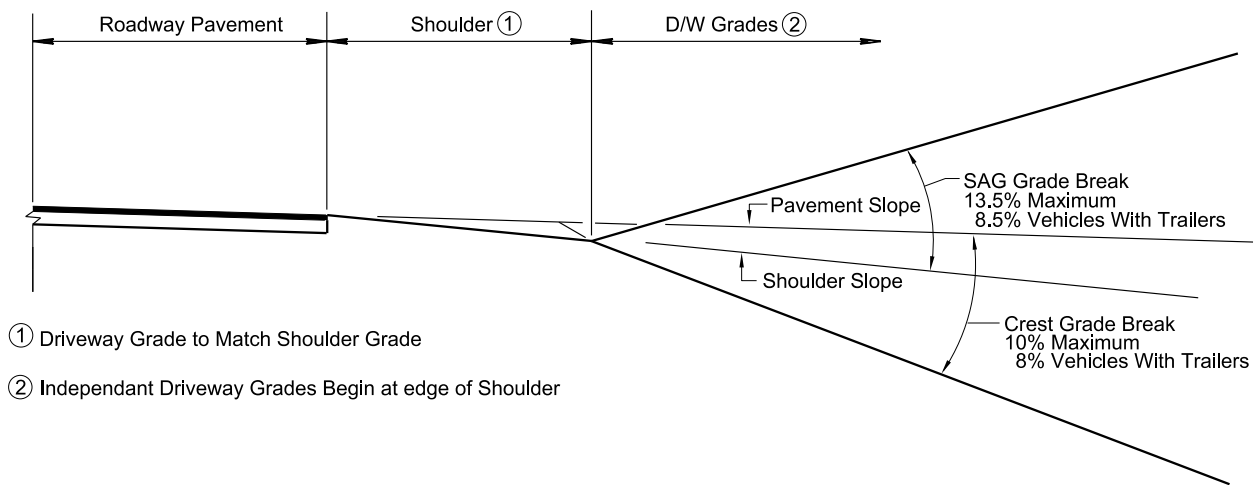
- a. Removing the sight obstruction
- b. Relocating the driveway to a more favorable location along the frontage
- c. Prohibiting critical movements at the driveway
- d. Relocating access to another street, a frontage road, or a joint access location

In all cases, stopping sight distance must be provided.

### **7.7.6 DRIVEWAY PROFILES**

Adequate design of driveway grades and profiles are to consider the basic functions of the adjacent street, the site that the access driveway serves, and the type of vehicles anticipated to use the driveway.

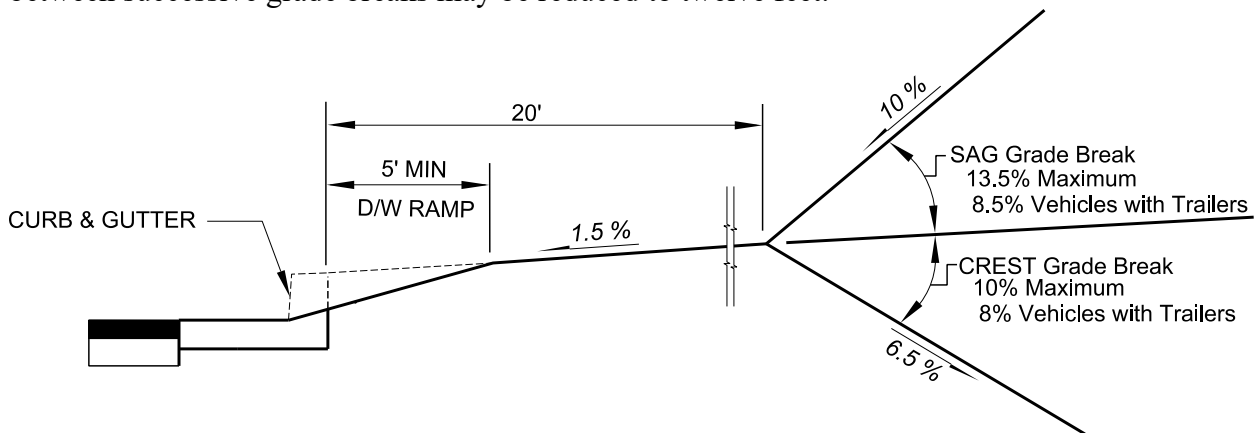
The profile of driveway connections to uncurbed roadways is to match the roadway pavement and shoulder grades; an independent driveway profile may begin at the outer edge of the roadway shoulder.



**FIGURE 7.4 - RURAL DRIVEWAY GRADES**

Driveway profiles are to provide sufficient clearance between the vehicle and the driveway surface to prevent high centering and hang-ups.

The ‘maximum’ driveway grade break changes identified in Table 7.3 will prevent high centering and hang-ups for most passenger cars. The ‘recommended’ driveway grade changes identified in Table 7.3 should be used for any vehicles with trailers to prevent high centering and hang-ups. Successive crest grade breaks and successive sag grade breaks are to be spaced no closer than the spacing between the front and rear axles. For design of driveway profiles twenty feet (20’) is the minimum distance to be used between successive crest grade breaks or successive sag grade breaks unless the sum of the grade breaks is less than the maximum design grade change. For single family residential driveways used only by passenger vehicles not pulling trailers the minimum distance between successive grade breaks may be reduced to twelve feet.



**FIGURE 7.5 - URBAN DRIVEWAY GRADES**

The maximum grade change without a vertical curve for a crest condition is 10% for passenger cars. The maximum grade change without a vertical curve for a sag condition is 13.5% for passenger cars. Vehicles with towed trailers cannot exceed a grade change of 8% for crest conditions and 8.5% for sag conditions. Access to properties that can accommodate vehicles with trailers must be evaluated by the Design Engineer if the grade change exceeds the maximum values in Table 7.3. The Design Engineer must demonstrate the proposed driveway grade change will not cause the vehicle or trailer to contact with the roadway surfaces when traversing the driveway.

**TABLE 7.3: DRIVEWAY % GRADE CHANGES WITHOUT A VERTICAL CURVE**

	Maximum (Passenger Cars)	Maximum (Vehicles w// Trailers)
Crest Condition	10	8
Sag Condition	13.5	8.5

### 7.7.7 DRIVEWAY TYPICAL SECTIONS

Driveway typical sections shall define embankment and cut slope requirements. Side slopes located within the roadway clear zone are transverse roadway slopes that are to be 1V:6H or flatter (1V:10H is the preferred rate along high speed roadways).

### 7.7.8 DRIVEWAY ANGLES

Two-way driveways and one-way driveways that are entering the roadway are to be aligned perpendicular (90°) to the roadway without angle points within the right of way. Driveway angle points when needed are to be located on private property. If conditions exist that prevent a perpendicular roadway connection, an angle of not less than 75° may be approved.

One-way driveway departing from a roadway may be as flat as 45°. However, a minimum of an 85° angle is recommended for driveways in areas of high pedestrian or bicycle activity.

One-way driveways entering a roadway at an angle less than 75° may be required to have a protected right turn acceleration lane that allows the entering vehicle to safely accelerate and merge into the through traffic lane.

### 7.7.9 DRAINAGE

Driveways along curbed roadways shall not allow street flow to be diverted. Drainage conditions downstream of the driveway shall not differ from that which would exist if the driveway was not present.

Driveways crossing roadside drainage ditches and channels shall not reduce the design capacity of the ditch or channel. If a culvert is installed, the water surface elevation at the culvert inlet shall be contained within the ditch or channel. Any increased potential for erosion resulting from driveway construction shall be mitigated. Ditch and channel flows are not to encroach onto roadway pavement at driveway locations.

Driveway culverts located within the roadway clear zone are to be made traffic safe.

### 7.7.10 SIDEWALKS

Driveways shall have an ADA compliant crossing for pedestrians contained within the right-of-way.

## **7.8 NUMBER OF DRIVEWAYS**

### **Originator: Transportation Systems Management & Operations Division**

The number of driveways is dependent upon the size and use of the property. Basically, each parcel is limited to one two-way driveway or a pair of one-way driveways. The driveway(s) are to satisfy the minimum driveway spacing criteria, as identified in Section 7.9.

Where a property has access to more than one road, access may be limited to the lowest volume road where the impacts of a new access will be minimized. Access on higher volume roads may be denied.

#### **7.8.1 ADDITIONAL DRIVEWAYS**

Additional driveways may be needed and provided under the following conditions:

- a. If the daily volume using one driveway would exceed 1,500 vehicles (both directions).
- b. If traffic using one driveway would exceed the capacity of a stop-sign-controlled intersection during one peak street traffic hour or the peak site traffic hour.
- c. If a traffic analysis shows that the traffic conditions warrant two or more driveways, and such driveways will not negatively impact traffic flow. When traffic flow on the County roadway will be negatively impacted, additional lanes may be required.

#### **7.8.2 TEMPORARY ACCESS**

Temporary access may be granted to undeveloped property prior to development of a final plan if access is needed for construction or preliminary site access. Temporary accesses are subject to removal, relocation, or redesign after final development plan approval.

Secondary access for emergency vehicles must be provided for all subdivisions and all other developments.

#### **7.8.3 LARGE DEVELOPMENTS**

For large developments, the MCDOT Director or an authorized representative may require the developer to consolidate access traffic to a single point which may be signalized. Driveway signals must be located to provide satisfactory signal progression for through traffic on the public road.

## **7.9 DRIVEWAY LOCATIONS**

### **Originator: Transportation Systems Management & Operations Division**

The edge of all driveways shall be at least 50' from the near edge of pavement or the near curb line of an intersecting street. The driveway spacing and driveway corner clearance distances shown for arterial and major collector roads in Section 7.9 are based on providing spacing equal to the stopping sight distance of the roadway being accessed. These location standards are desirable but may not be achievable for all situations. When a non-standard situation occurs that prevents compliance with the standards or the standards cause undue hardship, submit to MCDOT for evaluation a proposed installation together with documentation that justifies a need to deviate from the standard. A traffic analysis may be required to show the proposed non-compliant installation will not adversely impact traffic or be detrimental to public safety.

#### **7.9.1 DRIVEWAY LOCATION COORDINATION**

The location of a new proposed driveway or the relocation of an existing driveway can be crucial to public safety as well as providing efficient access to the property. Full access (all movements) driveways need to be located to minimize conflicts with adjacent and opposite driveways. For larger projects with proposed driveways on arterials, the locations along with LOS discussions are to be included in a traffic impact study.

Proposed driveways should be aligned with any existing driveways on the opposite side of the roadway to reduce conflicts. If conditions prevent alignment and require offset driveways to be constructed, the left turn movements should not overlap each other. Offset driveways shall be designed so the left turn movements do not share the same space in a two-way left turn lane or future two-way left turn lane. Where lots are not large enough to allow accesses on opposite sides of the street to be aligned, the center of driveways not in alignment should be offset a minimum of 250 feet on all major collector roads, and 360 feet on all industrial and arterial roads. Greater distances may be required due to left turn storage lane requirements.

#### **7.9.2 DRIVEWAY SPACING**

The distance between adjacent driveways must be adequate to allow driveway vehicles to safely queue, accelerate, decelerate, and cross conflicting traffic streams without excessive interference with through traffic, or traffic using adjacent driveways.

The minimum distance between driveway centerlines along arterial roadways shall be at least 360 feet.

The minimum distance between driveway centerlines along major collector roadways shall be at least 250 feet.

#### **7.9.3 JOINT ACCESS**

The use of joint access driveways connecting to arterial and collector roads is encouraged; fewer

access points improve the overall operation of the roadway. Joint access will be required for two adjacent developments where a proposed new access will not meet the spacing requirements set forth in this section. Joint access must be approved by the MCDOT Director or an authorized representative.

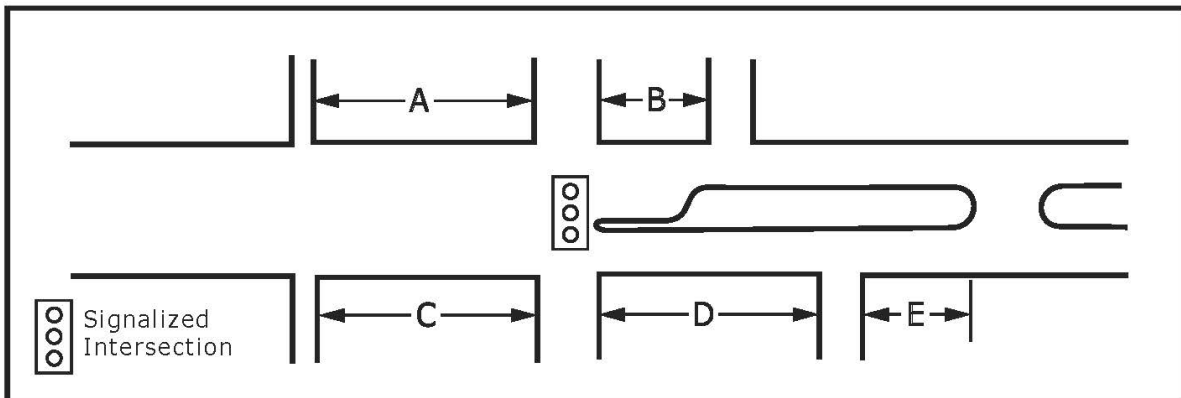
**7.9.4 DRIVEWAY CORNER CLEARANCE FOR ARTERIAL AND COLLECTOR ROADS**

Arterial-arterial and arterial- collector intersections may become signalized at a future time and shall be treated as signalized intersections whether or not a signal currently exists. Driveways located near a signalized intersection along a street with a posted speed of 40 mph or greater are to meet the Minimum Corner Clearance requirements shown in Table 7.4 and Figure 7.6. Table distances are the minimum clear distance between the edge of the roadway and the edge of the driveway.

TABLE 7.4: MINIMUM CORNER CLEARANCES (SIGNALIZED INTERSECTIONS)		
Distance	Functional Classification of Road	
	Arterial (ft.)	Collector (ft.)
A	360	250
B	180	125
C	360	250
D	360	250
E	75	75

**Distances shown are for 40 mph or greater posted speeds.**

- A. Distance downstream from signalized intersection to a fully directional access.
- B. Distance upstream from a signalized intersection to a right in / right out access.
- C. Distance upstream from a signalized intersection to a fully directional access.
- D. Distance downstream from a signalized intersection to a right in / right out access.
- E. Offset distance from a median break to a right in / right out access.



**FIGURE 7.6 – MINIMUM CORNER CLEARANCES (SIGNALIZED INTERSECTION)**

### **7.9.5 DRIVEWAY LOCATION RESTRICTIONS**

If a property has frontage on more than one street, access will be permitted only on those street frontages where standards contained in this manual and other County Regulations can be met.

Driveways shall not overlap or conflict with the location of a pedestrian curb ramp. Driveways shall not be located at a pedestrian roadway crossing.

Listed below are conditions where a new or proposed change to an existing driveway location will not be permitted.

- a. Within 10 feet of any commercial property line, except when it is a joint-use driveway serving two abutting commercial properties and access agreements have been exchanged between the two abutting property owners;
- b. Within 25 feet of a guardrail terminal;
- c. Within 100 feet of a bridge or other structure, except canal service roads;
- d. When adequate sight distance cannot be provided for vehicles on the driveway attempting to access the street, those movements will be prohibited;
- e. When the nearest edge of any driveway, driveway flare, or driveway radius has less than 2 feet of clearance from the nearest projection of a fire hydrant, utility pole, curb inlet, traffic signal, or light standard;

### **7.9.6 VARIANCES**

Exceptions may be made by the MCDOT Traffic Engineer where the application of these standards would create an undue hardship to the abutting property owners and good traffic management practice can be maintained.

## **7.10 DRIVEWAY STORAGE**

### **Originator: Transportation Systems Management & Operations Division**

The design of a driveway should take into consideration the space necessary to store vehicles using the driveway. This applies to both vehicles making a left turn from the roadway and to vehicles stopped on the driveway waiting to enter the roadway. Adequate storage area is necessary to provide safe and efficient movement of vehicles and pedestrians on the public right-of-way. Examples of on-site storage requirements are shown in Table - 7.5. All anticipated traffic entering a facility will need to be accommodated on-site so that no entering traffic is queuing onto any public roadway. For actual requirements for on-site development, see current Maricopa County Planning and Development Department publications.

<b>TABLE 7.5: VEHICLE STORAGE REQUIREMENTS</b>	
<b>Type Of Facility</b>	<b>Recommended Minimum Vehicle Storage<sup>3</sup></b>
Drive-in Bank	8 spaces per window <sup>1</sup>
Drive-in Restaurant	12 spaces per window <sup>2</sup>
Automatic Car Wash	7 spaces per wash line
Self-service Car Wash	3 spaces per wash line
<b>Security Check-in</b>	
a. Residential	3 spaces minimum, 1 space per 50 residences, maximum of 10 spaces
b. RV Park	a. 100 ft. for 0-20 RV sites b. 150 ft. for 20-40 RV sites c. 200 ft. for greater than 40 sites
c. Industrial	Based on traffic impact study
Charter Schools	0.15 spaces per student
Drive-in Liquor Store	3 spaces per window <sup>2</sup>
Drive-in Dry Cleaners	3 spaces per window <sup>2</sup>

- (1) A maximum of 30 spaces will be required for banks with more than 5 drive up windows.
- (2) Measured from the pick-up window, for some types of restaurants, a shorter stacking distance may be permitted.
- (3) Measured from point of service to the right of way line for incoming traffic.

Examples in Table 7.5 summarize the vehicle storage area requirements to be provided for various uses. These storage areas are:

- a. Based on a space size of 12 feet (width) by 20 feet (length).
- b. Separated from normal parking circulation aisles.
- c. Designed using the appropriate design vehicle turning template.

The vehicle storage area needed for the entire site may be spread over several accesses if more than one access serves the site. The recommended distance may be further adjusted by MCDOT for accesses with two approach lanes and will be subject to traffic volumes and site layout.

When a development is located adjacent to a public road, the parking facility must have full internal vehicular circulation and storage. Vehicular circulation must be located completely within the property and vehicles within one portion of the development must have access to all other portions without using the adjacent road system.

## **7.15 AUXILIARY LANES FOR DRIVEWAYS**

### **Originator: Transportation Systems Management & Operations Division**

Acceleration and/or deceleration lanes may be required at driveways to assist traffic entering or exiting the roadway. A warrant study evaluating these types of facilities is required during new construction, major reconstruction, or as part of the permit process as land is developed impacting traffic volumes in the area.

#### **7.15.1 RIGHT TURN LANE WARRANTS**

A driveway right turn deceleration lane is required when either of the following is met:

- Existing and/or Design Year peak hour right turn volumes meet or exceed the ranges presented in Table 7.6.
- Engineering judgment indicates a right-turn deceleration lane is warranted based on factors including shoulder width, percentage of trucks, sign distance, roadway grade, horizontal and vertical curvature, and crash history.

<b>TABLE 7.6: VOLUME WARRANTS FOR RIGHT-TURN LANES</b>					
Peak Hour Traffic Volume on the Highway in Advancing Direction	<b>Minimum Peak Hour Right-turn Traffic Volume</b>				
	<b># of thru lanes per direction</b>				
	1		2		3
	< 45 MPH Posted Speed	≥ 45 MPH Posted Speed	< 45 MPH Posted Speed	≥ 45 MPH Posted Speed	All Speeds
≤ 200	-	-	-	-	-
201 - 300	-	30	-	-	-
301 - 400	-	19	-	55	-
401 - 500	85	14	-	30	-
501 - 600	58	12	140	25	-
601 - 700	27	9	80	18	-
701 - 800	20	8	53	15	-
801 - 900	12	7	40	12	-
901 - 1000	9	6	30	11	-
1001 - 1100	8	5	23	9	18
1101 - 1200	7	5	18	8	16
1201 - 1300	6	4	14	8	15
1301 - 1400	6	4	11	6	12
1400 +	5	3	8	6	10

#### **7.15.2 LEFT TURN LANE WARRANTS**

A driveway left turn deceleration lane is warranted when either of the following is met:

- Existing and/or Design Year peak hour right turn volumes meet or exceed the ranges presented in Table 7.7.

- Engineering judgment indicates a right-turn deceleration lane is warranted based on factors including shoulder width, percentage of trucks, sign distance, roadway grade, horizontal and vertical curvature, and crash history.

**TABLE 7.7: VOLUME WARRANTS FOR LEFT-TURN LANES**

Peak Hour Traffic Volume on the Roadway in Advancing Direction	Minimum Peak Hour Left-Turn Traffic Volume			
	# of thru lanes per direction			
	1		2	
	< 45 MPH Posted Speed	≥ 45 MPH Posted Speed	< 45 MPH Posted Speed	≥ 45 MPH Posted Speed
≤ 200	30	15	-	-
201 -300	12	12	40	30
301 – 400	12	12	30	25
401 – 500	12	12	25	18
501 – 600	12	12	15	12
601 – 1000	12	12	10	8
1000 +	12	8	10	8

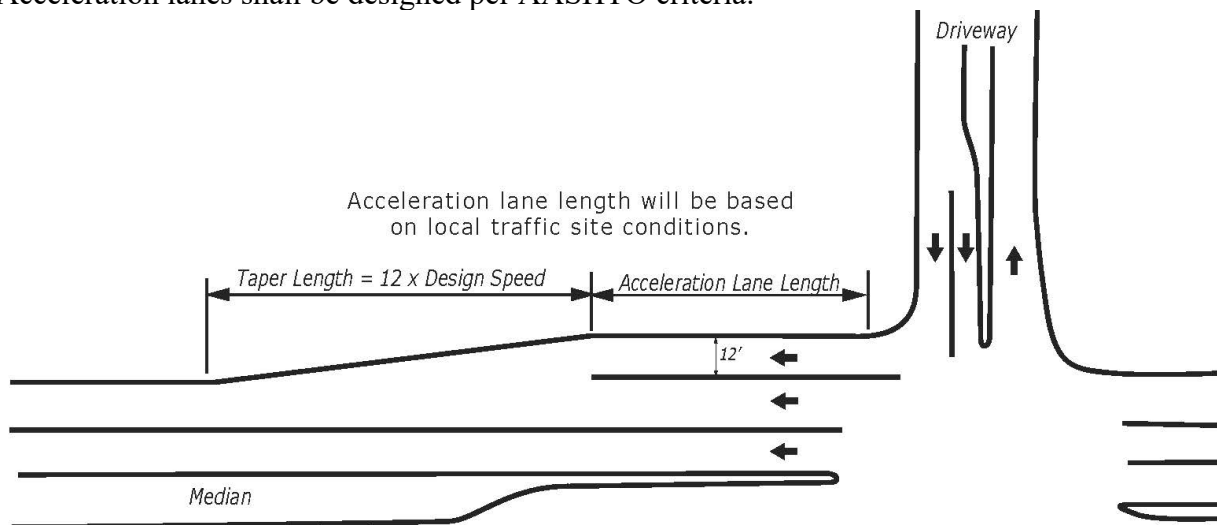
Left-turn access into a driveway or access point may be restricted as part of an access control effort on arterial and collector roadways to improve safety for roadway users. This will be handled case by case and be at the discretion of the County Traffic Engineer.

**7.15.3 ACCELERATION LANES**

Acceleration lanes are required when high traffic volume on the road and lack of gaps in traffic makes use of an acceleration lane necessary for vehicles to enter the highway traffic flow through the use of merging techniques. MCDOT may require an acceleration lane for public safety and traffic operations based on site specific conditions.

An acceleration lane will not normally be required when the posted speed is less than 35 mph.

Acceleration lanes shall be designed per AASHTO criteria.



**FIGURE 7.7 – RIGHT-TURN ACCELERATION LANES**

#### 7.15.4 GENERAL SPEED CHANGE, LANE CRITERIA

The general criteria shall apply to right and left turn lanes and acceleration lanes.

- a. When traffic safety so requires, due to specific site conditions such as sight distance, a speed change lane may be required even though the criteria as described in this section are not met.
- b. Where there are three or more through lanes in the direction of travel, the requirement for right turn acceleration and deceleration lanes may be dropped. Each case will be reviewed by the MCDOT Director or an authorized representative and a decision made based upon site specific conditions. Generally, lanes will be required only when a high volume access or a specific geometric safety problem exists.
- c. When calculating the peak hour volume in the outside lane, it will be assumed that all through lanes have equal volumes.
- d. Geometrics for auxiliary turn lanes shall be as shown in Chapter 6.

# **Chapter 8**

## **Design Guidelines for Bicycle Facilities**

**TABLE OF CONTENTS**

**CHAPTER 8      DESIGN GUIDELINES FOR BICYCLE FACILITIES**

**8.1 BASIC CRITERIA ..... 8-1**

**8.2 ROADWAY FACILITY DESIGN GUIDELINES ..... 8-2**

**8.3 SHARED USE PATH DESIGN GUIDELINES..... 8-4**

## **8.1 BASIC CRITERIA**

### **Originator: Engineering Division**

#### **8.1.1 GENERAL**

Bicycle lanes are included as part of the standard curbed cross section except for local streets and urban minor collector streets as shown in Chapter 5: Geometric Design Standards. Local streets and urban minor collector streets provide extra lane width to facilitate the sharing of the road between bicyclists and motorists.

#### **8.1.2 DEVELOPMENT OF PLANS AND SPECIFICATIONS**

Design, design details, and materials shall be in accordance with the current editions of the following publications:

- (1) Guide for the Development of Bicycle Facilities, The American Association of State Highway and Transportation Officials, ("AASHTO").
- (2) Manual on Uniform Traffic Control Devices (MUTCD), U.S. Department of Transportation, as amended and approved by the Arizona Department of Transportation.
- (3) Urban Bikeway Design Guide, National Association of City Transportation Officials (NACTO)

#### **8.1.3 DESIGN EXCEPTIONS**

Design exception requests shall follow the procedures given in Section 1.1.

## **8.2 ROADWAY FACILITY DESIGN GUIDELINES**

### **Originator: Engineering Division**

#### **8.2.1 PAVEMENT SURFACE**

- ◇ Pavement surfaces shall be designed free from irregularities and the edges of the pavement shall be uniform in width.
- ◇ Roads that are expected to have bicycle traffic shall not have "rumble strips."
- ◇ When chip sealing is used to recondition roadway surfaces, the cover material shall limit the maximum stone size to 3/8" on Bicycle lanes and shoulders.

#### **8.2.2 DRAINAGE GRATES AND UTILITY COVERS**

- ◇ When a new roadway is designed, all drainage grates and utility covers should be kept out of the bicyclists' expected path.
- ◇ Drainage grates and utility covers shall be adjusted flush with the pavement surface on all new construction and reconstruction.
- ◇ On new construction where bicyclists will be permitted, curb inlets rather than drainage grates should be used wherever possible.
- ◇ Bicycle safe drainage grates shall be used on all roadways.

#### **8.2.3 RAILROAD CROSSINGS**

- ◇ Railroad-highway grade crossings should ideally be at a right angle to the rails.
- ◇ Pavement surfaces at railroad crossings shall be designed, constructed, and maintained to permit safe, smooth crossings for all roadway users. If the crossing angle is less than approximately 45 degrees, consideration should be given to widening the outside lane, shoulder, or bicycle lane to allow bicyclists adequate room to cross the tracks at a right angle. Where this is not possible, commercially available compressed flange-way fillers can enhance bicyclists' safety. If cost is a factor, these need only be installed across the Bicycle lane portion of the total pavement width.
- ◇ Warning signs and pavement markings shall be installed in accordance with the Manual on Uniform Traffic Control Devices.

#### **8.2.4 ADDITIONAL ROADWAY HAZARDS**

- ◇ Smooth transitions should exist at all cattle guards, gutters, manholes, and all cut and patch sites on roadways.
- ◇ Raised pavement markings shall not be used directly along designated bicycle facilities.

## **8.2.5 BRIDGE TREATMENTS**

Bridge crossings shall incorporate facilities that will accommodate all traffic modes that exist or are planned on the roadways to and from the bridge. The design of roadway widths for bridges shall allow on-road Bicycle lanes to be continuous across the bridge.

## **8.2.6 TRAFFIC CONTROL DEVICES**

- ◇ Bicyclists should be taken into consideration in the timing of traffic signals and in the placement of traffic detection devices.
- ◇ Where programmed visibility signal heads are used, they shall be checked to ensure that they are visible to a bicyclist who is properly positioned on the road.
- ◇ The Manual on Uniform Traffic Control Devices should be consulted for guidance on signs and pavement markings.

## **8.2.7 BICYCLE ROUTES**

Signing of Bicycle route shall be in accordance with the Manual on Uniform Traffic Control Devices.

## **8.2.8 PAVED SHOULDERS**

The designation of paved shoulders as Bicycle lanes or Bicycle routes shall be a decision made by the MCDOT Engineering Division.

## **8.2.9 BICYCLE LANES**

- ◇ Bicycle lanes shall always be one-way facilities that carry traffic in the same direction as the adjacent motor vehicle lane. Two-way bicycle lanes on one side of the roadway are unacceptable.
- ◇ Bicycle lanes on one-way streets shall be placed on the right edge of the road, except in areas where placement on the left will significantly reduce conflict.
- ◇ The minimum bicycle lane width on urban (curbed) roadways where parking is prohibited shall be 4.5 feet, measured from the edge of the vehicle lane to the longitudinal joint between the roadway surface and the gutter pan. When the gutter pan is less than 12 inches in width, the minimum distance from the edge of the vehicle lane to the face of curb shall be 6 feet.
- ◇ The minimum bicycle lane width on non-curbed streets with no parking is 6 feet of useable pavement width.
- ◇ The minimum bicycle lane striped width for a curbed street where a parking lane is provided is 5 feet to the left of a minimum 10-foot wide parking area. Bicycle lanes shall always be placed between the parking lane and the through traffic lane. If the parking volume is substantial or turnover is high, an additional 1 or 2 feet of width is recommended for safe bicycle operation.

## **8.3 SHARED USE PATH DESIGN GUIDELINES**

### **Originator: Engineering Division**

#### **8.3.1 GENERAL**

- ◇ Shared use paths shall be designed to accommodate all expected users. These users may include but are not limited to pedestrians, bicyclists, and equestrians.
- ◇ Shared use paths are to minimize crossing by motor vehicles.
- ◇ On- and off-street bicycle facilities are to complement and connect with each other.
- ◇ Design shall comply with the most recent edition of the following:
  - Americans with Disabilities Act (ADA) design standards,
  - AASHTO Guide for the Development of Bicycle Facilities,
  - Design guidelines from FHWA, and other nationally recognized organizations approved by the MCDOT Traffic Engineer.
- ◇ Standard sidewalk widths do not constitute an acceptable shared use path or bicycle facility.

#### **8.3.2 SHARED USE PATH WIDTH AND CLEARANCE DISTANCES**

- ◇ The minimum width for a paved shared use path is ten feet. Twelve feet is recommended where high use is expected.
- ◇ The minimum width for an unpaved shared use path is six feet. Widths up to ten feet are acceptable if high use is anticipated.
- ◇ A minimum two-foot wide stabilized surface area shall be provided adjacent to both sides of pathway pavements. This area shall remain free from obstructions and serve as a two-foot clear zone and be included within the designated right-of-way.
- ◇ The shared use path vertical clear distance shall be ten feet minimum.
- ◇ Shared use paths adjacent to streets or roadways must be separated by at least five feet from the back of curb unless a barrier is provided.
- ◇ One-way shared use paths are not acceptable.
- ◇ Accessible ramps should be the same width as the shared use path.

#### **8.3.3 SHARED USE PATH DESIGN SPEED**

The minimum design speed for paved shared use paths is 18 mph. In areas with hilly terrain and sustained steep grades (six percent or greater) the appropriate design speed should be selected based on the anticipated travel speeds of bicyclists going downhill. In all but the most extreme cases, 30 mph should be the maximum design speed.

#### **8.3.4 SHARED USE PATH HORIZONTAL ALIGNMENT AND SUPERELEVATION**

- ◇ The maximum superelevation rate is two percent (2%).
- ◇ The minimum design radius of curvature shall be derived from the formulas and figures provided in the AASHTO Guide for the Development of Bicycle Facilities.
- ◇ Where curves are used along paths, proper warning signs, pavement markings and

additional width shall be provided in accordance with the AASHTO Guide for the Development of Bicycle Facilities and the Manual on Uniform Traffic Control Devices.

### **8.3.5 SHARED USE PATH GRADES**

Grades greater than 5 percent are not recommended. Where the terrain dictates, grades over 5 percent may be allowed for short distances. Refer to the ADA Standards of Accessible Design and AASHTO Guide for the Development of Bicycle Facilities for specific grade restrictions and grade lengths.

### **8.3.6 SHARED USE PATH SIGHT DISTANCES**

The minimum sight distance shall be derived from figures and formulas contained in the AASHTO Guide for the Development of Bicycle Facilities.

### **8.3.7 SHARED USE PATH INTERSECTIONS**

- ◇ The number of path and roadway /driveway intersections should be minimized.
- ◇ Right-of-way shall include areas required for adequate sight distance for turning movements.
- ◇ Shared use path intersections and approaches shall be on as flat of a grade as practical. Intersection grades shall not exceed two percent (2%).
- ◇ Adequate advance warning of intersections shall be given to afford bicyclists a safe stopping distance.
- ◇ For traffic control devices, application of the Manual on Uniform Traffic Control Devices warrant criteria shall be used (signal, stop sign, yield sign, etc.).
- ◇ Sign type, size, and location shall be in accordance with guidance provided in the Manual on Uniform Traffic Control Devices.

### **8.3.8 SHARED USE PATH SIGNING AND MARKING**

Uniform application of traffic control devices (signs and markings), are described in the Manual on Uniform Traffic Control Devices. A 4-inch wide yellow centerline stripe shall be used to separate opposite directions of travel along paved shared use paths under the following circumstances:

- (1) For heavy volumes of bicycles,
- (2) On curves with a restricted sight distance,
- (3) On unlit paths.

### **8.3.9 SHARED USE PATH SURFACING**

- ◇ Paved shared use paths shall be constructed of either asphalt concrete or Portland cement concrete. A pavement design report prepared and sealed by a Professional Engineer shall be submitted to MCDOT.
- ◇ Pavements are to be designed to sustain, without damage, wheel loads of emergency, patrol, maintenance, and other motor vehicles that are expected to use or cross the path.
- ◇ Pavements for shared use paths shall provide a smooth and consistent surface. Skid resistance qualities shall not be sacrificed for the sake of smoothness.

### **8.3.10 SHARED USE PATH LIGHTING**

- ◇ For illuminated paths an average maintained horizontal illumination level of 0.5 foot-candle to 2 foot-candles is recommended.
- ◇ Light standards (poles) shall meet the recommended horizontal and vertical clearances.

### **8.3.11 SHARED USE PATH DRAINAGE**

- ◇ A standard surface cross slope of 1½% shall be provided.
- ◇ One-way slopes shall be used. Crowned pathways shall not be permitted.
- ◇ Provide drainage facilities that will prevent concentrate flows from flowing across the pathway pavement and to prevent ponding on the pavement.
- ◇ Locate manhole covers and drainage grates away from the pathway pavement.

### **8.3.12 SHARED USE PATH RESTRICTION OF MOTOR VEHICLES**

Removable bollard posts or other approved devices may be used to restrict unauthorized access to paths. Bollard posts shall be permanently reflectorized for nighttime visibility and painted a bright color for daytime visibility. Provide clear five-foot pathway openings between bollards and other restrictions.

# **Chapter 9**

## **Landscaping**

**TABLE OF CONTENTS**

**CHAPTER 9 LANDSCAPING**

**9.1 LANDSCAPE DESIGN..... 9-1**  
9.1.1 PURPOSE ..... 9-1  
9.1.2 DESIGN CONSIDERATIONS ..... 9-1

**9.2 DESIGN CRITERIA ..... 9-2**  
9.2.1 SIGHT DISTANCES, SIGHT LINES, AND SIGHT TRIANGLES ..... 9-2  
9.2.2 ROADSIDE DEVELOPMENT ..... 9-8  
9.2.3 LANDSCAPING IN MEDIANS ..... 9-9  
9.2.4 GRADING, DRAINAGE, AND IRRIGATION ..... 9-9

**9.3 USE OF PLANT MATERIALS ..... 9-13**  
9.3.1 PRESERVATION OF EXISTING VEGETATION ..... 9-13  
9.3.2 PROTECTED PLANTS ..... 9-13  
9.3.3 PLANT SALVAGE ..... 9-13  
9.3.4 RECOMMENDED PLANT LIST AND USE OF TURF GRASS ..... 9-13  
9.3.5 PLANTING RECOMMENDATIONS AND CONSIDERATIONS ..... 9-14  
9.3.6 PLANT DENSITY ..... 9-16  
9.3.7 INERT MATERIALS ..... 9-16  
9.3.8 LANDSCAPE PLANS ..... 9-17

**9.4 MAINTENANCE AND COSTS ..... 9-22**  
9.4.1 CONSIDERATIONS FOR MAINTENANCE: ..... 9-22  
9.4.2 VEHICULAR ACCESS ..... 9-22  
9.4.3 ROADSIDE MAINTENANCE RESPONSIBILITIES ..... 9-22

**LIST OF FIGURES**

FIGURE 9.1 – INTERSECTION DEPARTURE SIGHT TRIANGLES..... 9-3  
FIGURE 9.1a – DEPARTURE SIGHT TRIANGLES FOR PASSENGER CARS..... 9-4  
FIGURE 9.1b – DEPARTURE SIGHT TRIANGLES FOR SINGLE UNIT TRUCKS ..... 9-5  
FIGURE 9.1c – DEPARTURE SIGHT TRIANGLES FOR COMBINATION TRUCKS..... 9-6  
FIGURE 9.2 – SIGHT LINES TO SIGNS ..... 9-7  
FIGURE 9.3 – OFFSET AND CLEARANCE DISTANCES ..... 9-9  
FIGURE 9.4 – RURAL MINOR ARTERIAL ROAD ..... 9-18  
FIGURE 9.5 – RURAL PRINCIPAL ARTERIAL ROAD..... 9-19  
FIGURE 9.6 – URBAN MINOR ARTERIAL ROAD..... 9-20  
FIGURE 9.7 – URBAN PRINCIPAL ARTERIAL ROAD ..... 9-21

**LIST OF TABLES**

TABLE 9.1: VEHICLE TYPE FOR DETERMINING DEPARTURE SIGHT TRIANGLES .. 9-2  
TABLE 9.2: PLANTS WITH A MATURE HEIGHT TYPICALLY LESS THAN OR EQUAL  
TO 2 FEET ..... 9-11  
TABLE 9.3: PLANTS NOT ALLOWED TO BE PLANTED IN RIGHT OF WAY ..... 9-15

## **9.1 LANDSCAPE DESIGN**

### **Originator: Transportation Systems Management & Operations Division**

#### **9.1.1 PURPOSE**

These Landscape Design Standards have been written to serve as a guide to landscape architects and highway engineers for the purpose of designing and reviewing roadway landscaping plans.

#### **9.1.2 DESIGN CONSIDERATIONS**

The surroundings in which the roadway is being designed will have a strong influence on the landscape design. The design shall be respectful of existing natural features such as landforms and vegetation. When the roadway traverses urban developed areas, the landscape design shall reinforce the adjacent landscape theme or character. The principles of low maintenance and low water use shall be incorporated into all landscape designs.

Under no circumstances shall the landscape design compromise the safety of roadway users: motorists, pedestrians, bicyclists, and maintenance workers.

Many elements need to be considered during development of the landscape design. The landscape design process shall begin with a thorough inventory and analysis of existing conditions, including: the natural landscape elements, topographic and physical characteristics, ecological factors, recreational potentials, residential qualities, historical features and visual values.

## 9.2 DESIGN CRITERIA

### Originator: Transportation Systems Management & Operations Division

#### 9.2.1 SIGHT DISTANCES, SIGHT LINES, AND SIGHT TRIANGLES

When designing landscaping along roadways and near intersections and driveways, placement and height restrictions for plants and landscaping materials shall be observed. The purpose of these restrictions is to provide drivers with a clear view of signs and roadway conditions, allowing vehicles to turn safely at driveways and intersections.

Intersection and driveway departure sight triangles shall be maintained clear of sight obstructions. Sight triangle dimensions are influenced by roadway classification, vehicle speed, terrain, and vehicle type. Roadway classifications are as designated by MCDOT. Intersection Sight Distance is calculated using the roadway design speed and the time gap for the vehicle type shown in Table 9.1. Driveway Sight Distance is calculated using the roadway posted speed modified as indicated in section 7.7.5 and the time gap for the vehicle type indicated in Table 9.1. Departure sight triangles shall be shown, dimensioned, and labeled on the landscape plans, see Figure 9.1. The sight distances A (to the right) and B (to the left) are calculated from the formula  $D = 1.47 V_{\text{major}} t_g$ . The values for  $t_g$  are determined as identified in the AASHTO publication *A Policy on Geometric Design of Highways and Streets*. When requested, profiles along sight lines shall be submitted for review.

**TABLE 9.1: VEHICLE TYPE FOR DETERMINING DEPARTURE SIGHT TRIANGLES**

Major Road Classification	Minor Road Classification	Vehicle 1		
		Right Turn	Left Turn	Cross
Arterial	Arterial	Combination Truck	Combination Truck	Single Unit Truck
Arterial	Collector	Single Unit Truck	Single Unit Truck	Single Unit Truck
Arterial	Local	Single Unit Truck	Single Unit Truck	Single Unit Truck
Arterial	Commercial Industrial Driveway	Combination Truck	Combination Truck	-----
Arterial	Residential Driveway	Passenger Car	Passenger Car	-----
Collector	Collector	Single Unit Truck	Single Unit Truck	Single Unit Truck
Collector	Local	Single Unit Truck	Single Unit Truck	Single Unit Truck
Collector	Commercial Industrial Driveway	Single Unit Truck	Single Unit Truck	-----
Collector	Residential Driveway	Passenger Car	Passenger Car	-----
Local	Local	Single Unit Truck	Single Unit Truck	Single Unit Truck
Residential Subdivision Local	Residential Subdivision Local	Passenger Car	Passenger Car	Passenger Car
Local	Commercial Industrial Driveway	Single Unit Truck	Single Unit Truck	-----
Local	Residential Driveway	Passenger Car	Passenger Car	-----

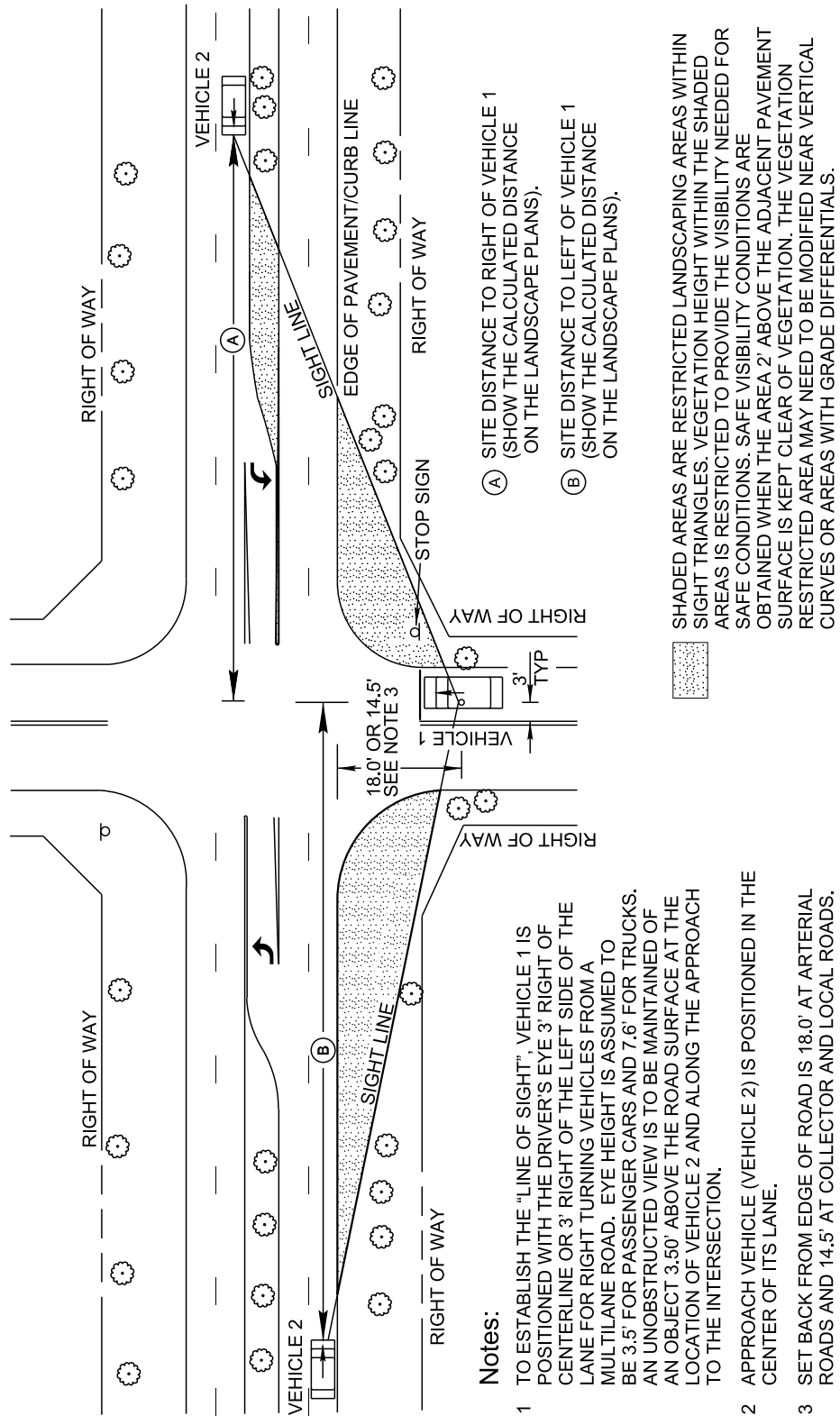
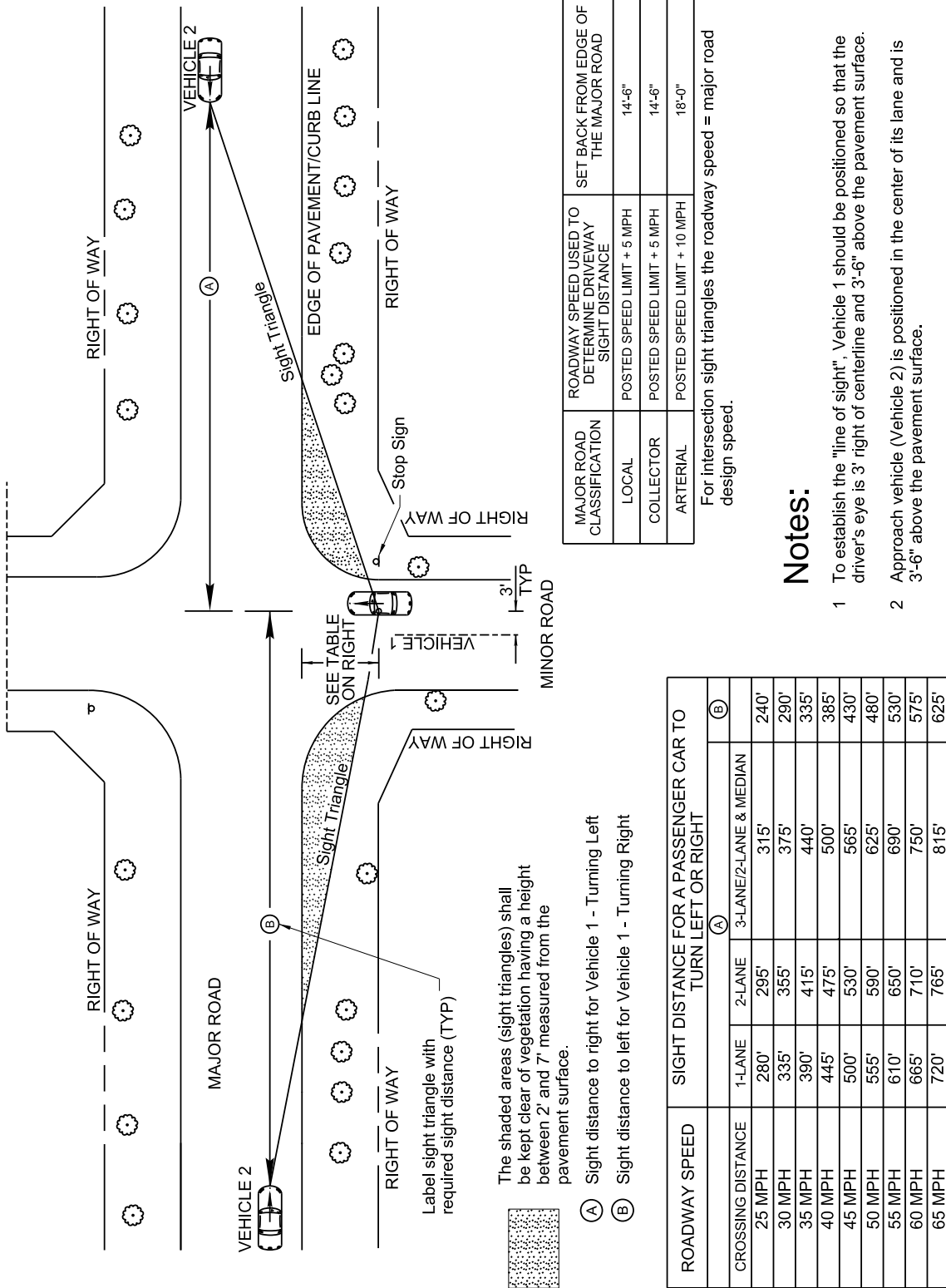


FIGURE 9.1 – INTERSECTION DEPARTURE SIGHT TRIANGLES



MAJOR ROAD CLASSIFICATION	ROADWAY SPEED USED TO DETERMINE DRIVEWAY SIGHT DISTANCE	SET BACK FROM EDGE OF THE MAJOR ROAD
LOCAL	POSTED SPEED LIMIT + 5 MPH	14'-6"
COLLECTOR	POSTED SPEED LIMIT + 5 MPH	14'-6"
ARTERIAL	POSTED SPEED LIMIT + 10 MPH	18'-0"

For intersection sight triangles the roadway speed = major road design speed.

**Notes:**

- 1 To establish the "line of sight", Vehicle 1 should be positioned so that the driver's eye is 3' right of centerline and 3'-6" above the pavement surface.
- 2 Approach vehicle (Vehicle 2) is positioned in the center of its lane and is 3'-6" above the pavement surface.
- 3 Table values assume approach grade for Vehicle 1 is less than 3%.

FIGURE 9.1a – DEPARTURE SIGHT TRIANGLES FOR PASSENGER CARS

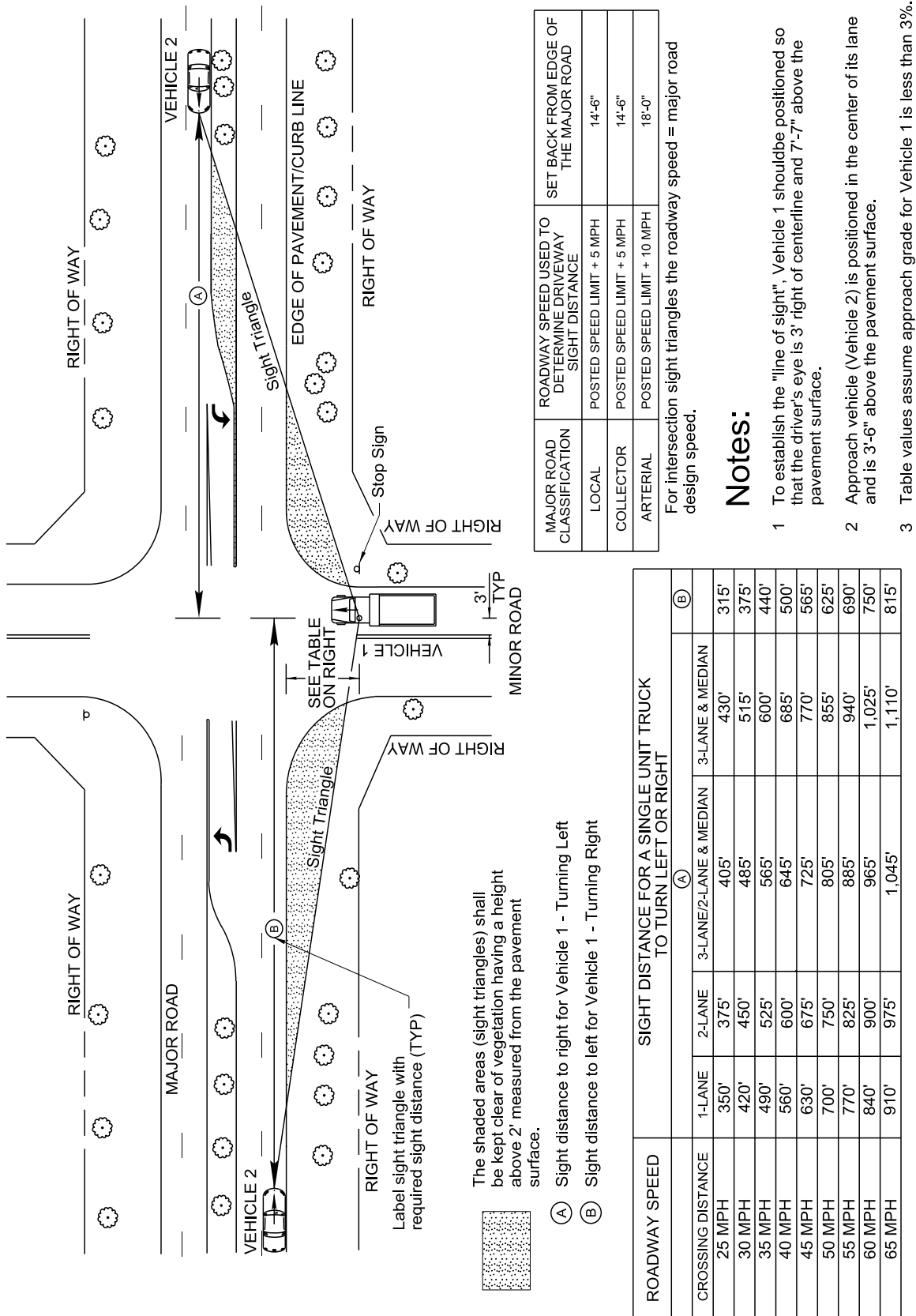


FIGURE 9.1b – DEPARTURE SIGHT TRIANGLES FOR SINGLE UNIT TRUCKS

MAJOR ROAD CLASSIFICATION	ROADWAY SPEED USED TO DETERMINE DRIVEWAY SIGHT DISTANCE	SET BACK FROM EDGE OF THE MAJOR ROAD
LOCAL	POSTED SPEED LIMIT + 5 MPH	14'-6"
COLLECTOR	POSTED SPEED LIMIT + 5 MPH	14'-6"
ARTERIAL	POSTED SPEED LIMIT + 10 MPH	18'-0"

For intersection sight triangles the roadway speed = major road design speed.

**Notes:**

- 1 To establish the "line of sight", Vehicle 1 should be positioned so that the driver's eye is 3' right of centerline and 7'-7" above the pavement surface.
- 2 Approach vehicle (Vehicle 2) is positioned in the center of its lane and is 3'-6" above the pavement surface.
- 3 Table values assume approach grade for Vehicle 1 is less than 3%.

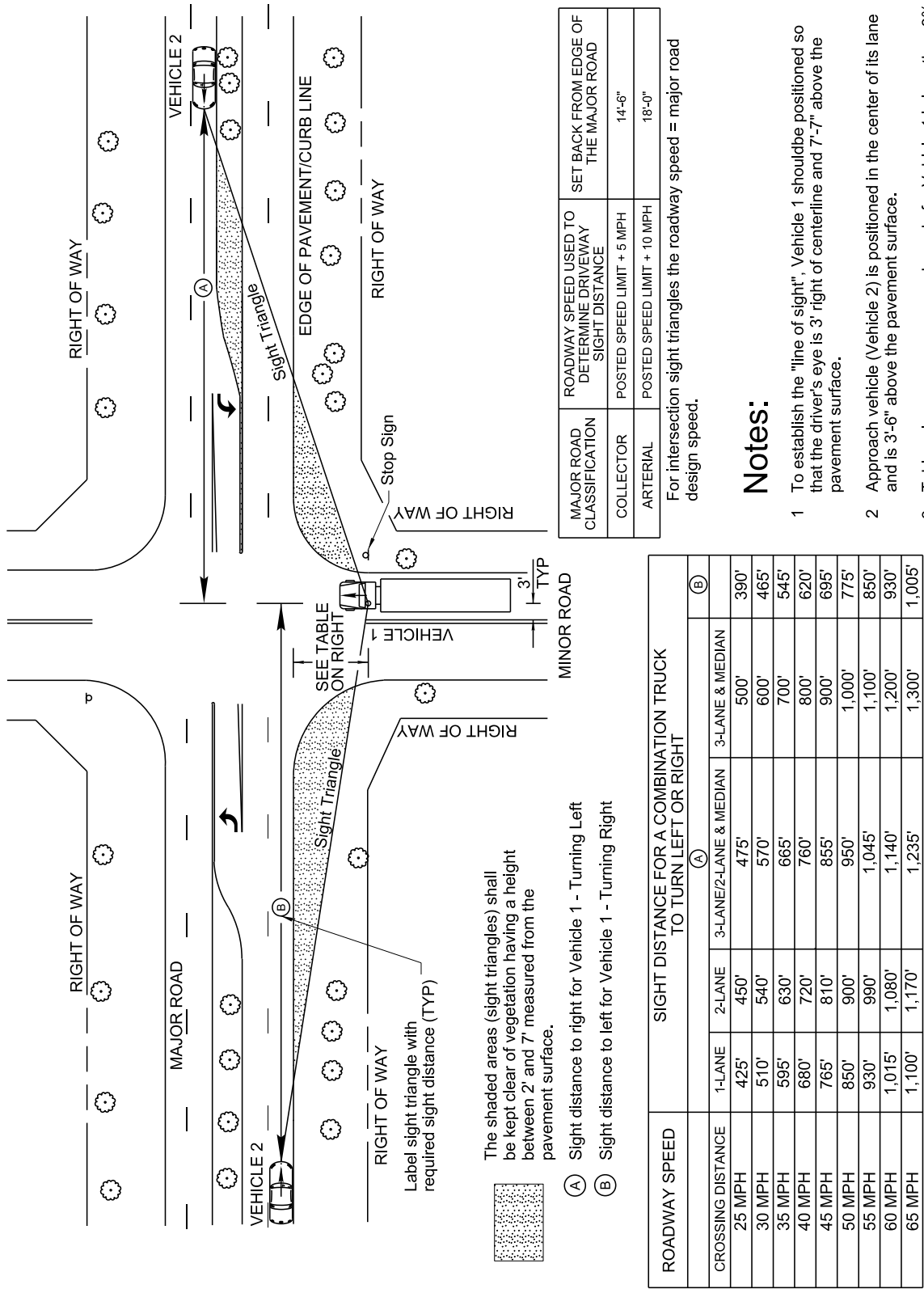


FIGURE 9.1c – DEPARTURE SIGHT TRIANGLES FOR COMBINATION TRUCKS

Vegetation height within sight triangles is restricted to provide the visibility needed for safe driving conditions. An open area clear of vegetation is to be maintained 2-feet above the adjacent roadway grade within the sight triangle area. Plants cannot be planted within the sight triangle if they have a potential to reach a mature height greater than 2-feet above the adjacent roadway pavement elevation. The restricted open area may be modified near vertical curves or differential grades to provide appropriate visibility. No trees, shrubs or cacti greater than 2 feet in height at maturity shall be planted in the sight triangle.

Table 9.2 contains a list of plants generally considered to have a mature height of less than 2 feet. Before using any of the plants identified in Table 9.2, the designer shall evaluate the plant choice for compliance with the sight line criteria. Other plants may be considered by MCDOT for use on a project-by-project basis.

Vegetation shall not block sight lines to signs. The entire sign panel of every traffic control sign and street name sign shall be visible to approaching vehicles for a distance equal to the stopping sight distance shown in Table 5.11. Both passenger vehicles (assumed eye height of 3.5') and trucks (assumed eye height of 7.6') shall have an unobstructed view of the complete sign panel of each sign. The vehicle driver's eye is assumed to be 3' right of the left line of the lane. All signs shall be shown on the landscape plans. Sight lines for all signs shall be shown and labeled on the landscape plans. The stopping sight distance is to be shown along the sign sight line.

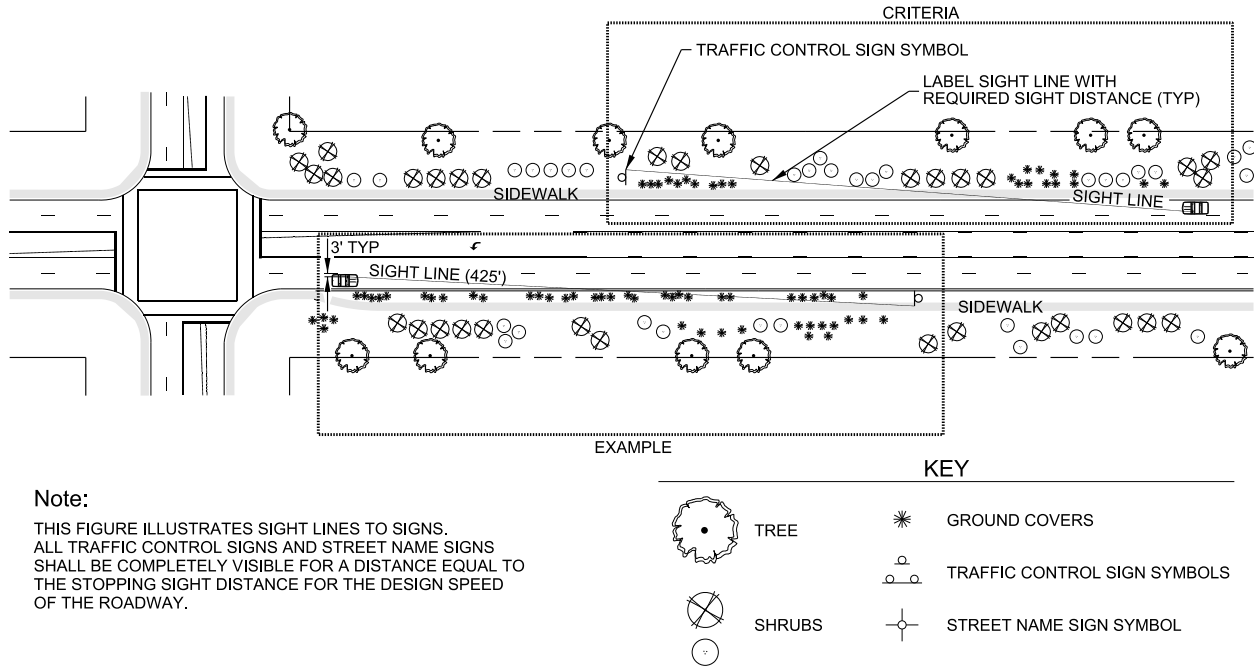


FIGURE 9.2 – SIGHT LINES TO SIGNS

Stopping sight distance sight lines are to remain unobstructed for the entire roadway area in the direction of travel. At roadway curves, these sight lines may extend across landscaped areas along the roadside or in the median. Stopping sight distance sight lines for the design speed of the roadway shall be maintained clear of sight obstructions. Special attention needs to be given to landscaped areas on the inside of sharp roadway curves and landscaped areas at the approach to the turnouts for auxiliary lanes.

## 9.2.2 ROADSIDE DEVELOPMENT

### A. Clear Zone Restrictions

Trees, large shrubs and cacti whose trunk diameter at maturity will exceed 4 inches are considered hazardous objects and are not to be planted within the clear zone. The diameter measurement shall be taken at 12 inches above grade. Refer to Section 5.25 for information on clear zone width. The clear zone width is not to be considered a fixed single control dimension. Variations in cross section design and traffic speed may increase or decrease this distance. Shrubs and ground covers may be planted or retained within the clear zone for safety and aesthetic purposes as approved by MCDOT. Existing trees may be retained under the following circumstances:

- If they are on the high or cut side of the roadway beyond the clear zone distance or,
- If they are on the low or fill side, if protected by a guardrail or beyond the clear zone distance.

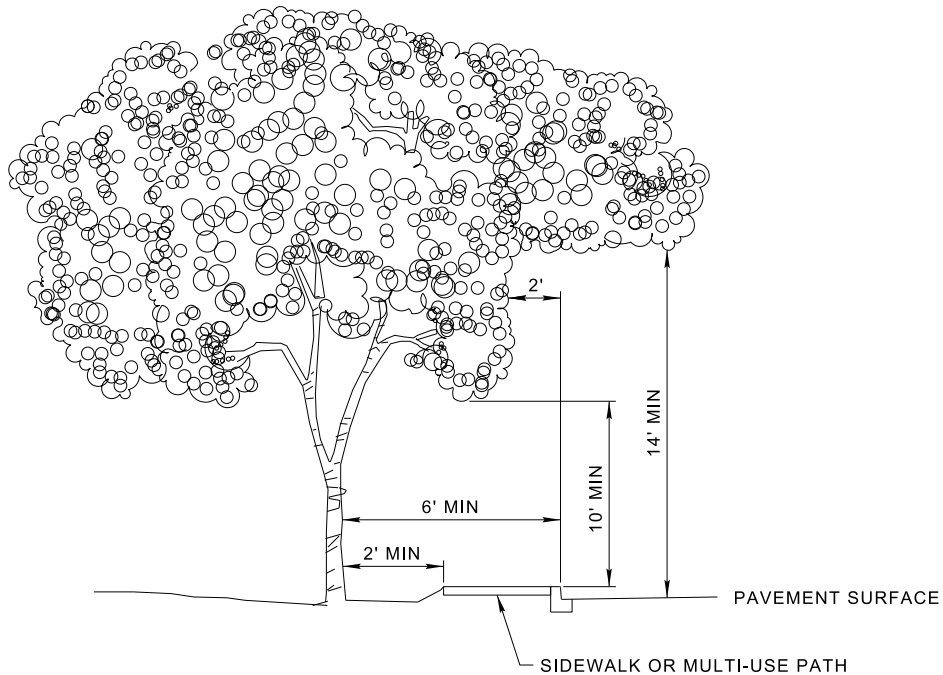
Clear zone distances shall be maintained for newly planted trees, shrubs and cacti with an ultimate trunk diameter of more than 4 inches unless one of the following allows for a lesser distance:

- i. Ten feet (10') behind the point of vertical intersection (PVI) at the toe of cut slopes steeper than 3:1.
- ii. Four feet (4') behind concrete barriers, walls, abutments, or other rigid obstructions.
- iii. Four feet (4') behind flexible guardrail.

### B. Offset and Clearance Distances for Trees

Along curbed roadways trees shall be located to maintain at least a six foot (6') clear distance from the face of curb when mature. Fourteen feet (14') of clearance shall be maintained between the overhanging canopy of trees and the roadway pavement and shoulder surfaces. For curbed roadways the fourteen feet (14') of clearance shall extend a minimum of two feet (2') behind the face of curb.

Trees shall be offset from the edge of bicycle facilities and sidewalks to provide, at maturity, a minimum clear distance of two feet (2'). Ten feet (10') of clearance shall be maintained between the overhanging canopy of trees and the surface of sidewalks and bicycle facilities.



**FIGURE 9.3 – OFFSET AND CLEARANCE DISTANCES**

### 9.2.3 LANDSCAPING IN MEDIANS

Landscaping can improve roadway aesthetics, mitigate headlight glare, provide impact attenuation, and reduce the potential for driver monotony. A landscaped median can also reduce the perceived scale of the roadway.

Trees shall not be planted in the median. Shrubs or cacti that will exceed 4 inches in diameter at maturity shall not be planted in the median except when located at least six feet (6') behind vertical curb.

#### **Mitigation of Headlight Glare**

The value of screening for glare depends on road alignment, ground forms, existing vegetation, and the width of the median. Where sight distance is not impaired, plantings should be at least 4 feet high and form a continuous screen, to avoid intermittent glare.

#### **Impact Attenuation**

Dense shrub masses, by their slower decelerating effect, cause less damage and injury to car and driver than do solid barriers. However, they may require 2 to 3 years to become firmly rooted and well grown. In the median, multiple rows of dense shrubs are effective, if space is available.

### 9.2.4 GRADING, DRAINAGE, AND IRRIGATION

#### **Soil Conservation**

Favorable soil conditions contribute to successful landscape plantings and site restoration. On

projects determined by MCDOT, topsoil shall be salvaged prior to construction. Before grading work begins, acceptable topsoil within the excavation and embankment areas shall be removed to a depth of not less than 4 inches below the existing ground surface. Stripped material shall be stockpiled and used as required as shown on the landscaping plans or stockpiled for future use at an acceptable location.

### **Grading**

The proper shaping of slopes can benefit drainage, erosion control, aesthetic, and future maintenance. Grading plans shall be used wherever feasible. The grading shall always be smooth enough to meet safety requirements, permit easy maintenance, and adequately serve the needs of surface drainage. Grading shall integrate the hydrology, aesthetic and earthwork needs for the site and maximize use of stormwater runoff to support the landscape development.

### **Erosion Control**

In planting design, the following parameters shall be considered to control erosion:

- Slopes with ratios of 3(h):1(v) and flatter favor the establishment of natural vegetation as protection against erosion. Slopes with ratios of 4(h):1(v) and flatter add to highway safety.
- Plant along the contour of the slope. Avoid planting arrangements that would encourage erosion.
- Stabilize soils at dip sections in both the right-of-way and the median where applicable. The use of decomposed granite in dip sections is prohibited.

### **Underground Irrigation**

The use of plants which, once established, can survive on minimal supplemental watering or natural rainfall is recommended for areas to be maintained by MCDOT. MCDOT generally does not provide landscape irrigation facilities in the right-of-way.

In urban areas or in special cases as determined by MCDOT, underground irrigation will be necessary to establish and maintain new plantings. Such underground systems will improve the health of the plants and improve the overall appearance of the highway. Adjacent property owners who desire landscape improvements that will require periodic or full-time irrigation can enter into an agreement with MCDOT to provide funding for all or portions of the landscaping, irrigation system and associated long-term maintenance of the improvements within County right-of-way.

It is important that the area to be landscaped is large enough to accommodate the plants and any associated irrigation components, if an irrigation system is planned for the area. Irrigation components such as valves and controllers shall be placed as close to the right-of-way limits as possible, and within a vault when possible. All underground landscape equipment within 5 feet of back of curb, or back of sidewalk, or within 15 feet of edge of pavement must have 36 inch minimum depth of cover.

If provisions are being made for future irrigation, install sleeves under streets, drives and impervious surfaces with six-inch schedule 40 PVC. The sleeves shall extend beyond the impervious surface to a length equal to the depth at which the sleeves are placed.

**TABLE 9.2: PLANTS WITH A MATURE HEIGHT TYPICALLY LESS THAN OR EQUAL TO 2 FEET**

The plants listed herein have been generally accepted as having growth patterns that will allow sight lines to be maintained without excessive maintenance. However, numerous factors can cause individual plants of each species to manifest differing, unacceptable growth characteristics. Under circumstances of excessive irrigation and/or fertilization, favorable climatic and/or growing conditions, and/or lack of regular maintenance, the identified plants may exceed the growth patterns shown. Direct knowledge and experience by the landscape designer of a specific plant within certain settings or geographic areas of the County, may justify non-use of some of the listed plants. All plants must be maintained in compliance with the visibility requirements given in Section 9.2. Therefore, the landscape designer shall carefully evaluate each plant chosen so that compliance with the criteria in Section 9.2 is achieved with minimal maintenance.

<b>Botanical Name</b>	<b>Common Name</b>
<i>Acacia redolens</i> 'Desert Carpet'	Trailing Acacia
<i>Agave felgeri</i>	Agave
<i>Agave parryi</i>	Parry's Agave
<i>Agave victoriae-reginae</i>	Royal Agave
<i>Aloe saponaria</i>	Tiger Aloe
<i>Aloe vera</i>	Medicinal Aloe
<i>Ambrosia deltoidea</i>	Triangleleaf Bursage
<i>Ambrosia dumosa</i>	White Bursage
<i>Aristida purpurea</i>	Purple Threeawn
<i>Asparagus densiflorus</i> 'Sprengeri'	Sprenger Asparagus
<i>Baileya multiradiata</i>	Desert Marigold
<i>Berlandiera lyrata</i>	Chocolate Flower
<i>Bouteloua gracilis</i>	Blue Grama
<i>Chrysactinia mexicana</i>	Damianita
<i>Convolvulus cneorum</i>	Bush Morning Glory
<i>Convolvulus mauritanicus</i>	Ground Morning Glory
<i>Dalea capitata</i> 'Sierra Gold'	Sierra Gold Dalea
<i>Dalea greggii</i>	Trailing Indigo Bush
<i>Dyssodia acerosa</i>	Dyssodia
<i>Dyssodia pentachaeta</i>	Dyssodia
<i>Echinocactus grusonii</i>	Golden Barrel
<i>Echinocereus engelmannii</i>	Engelmann's Hedgehog
<i>Ericameria laricifolia</i>	Turpentine Bush
<i>Erigeron divergens</i>	Spreading Fleabane
<i>Eriogonum fasciculatum</i>	Flattop Buckwheat
<i>Eriogonum wrightii</i>	Wright Buckwheat
<i>Gazania rigens</i>	Gazania
<i>Gutierrezia microcephala</i>	Snakeweed
<i>Hechtia montana</i>	Hechtia
<i>Hymenoxys acaulis</i>	Angelita Daisy
<i>Lantana montevidensis</i>	Trailing Lantana
<i>Lotus rigidus</i>	Desert Rock Pea

<b>TABLE 9.2: PLANTS WITH A MATURE HEIGHT TYPICALLY LESS THAN OR EQUAL TO 2 FEET (Continued)</b>	
<b>Botanical Name</b>	<b>Common Name</b>
<i>Malephora lutea</i>	<i>Rocky Point Ice Plant</i>
<i>Manfreda maculosa</i>	<i>Manfreda</i>
<i>Melampodium leucanthum</i>	<i>Blackfoot Daisy</i>
<i>Myoporum parvifolium</i>	<i>Myoporum</i>
<i>Oenothera berlandieri</i>	<i>Mexican Evening Primrose</i>
<i>Oenothera caespitosa</i>	<i>Tufted Evening Primrose</i>
<i>Oenothera stubbei</i>	<i>Saltillo Primrose</i>
<i>Opuntia basilaris</i>	<i>Beavertail Prickly Pear</i>
<i>Penstemon baccharifolius</i>	<i>Baccharisleaf Penstemon</i>
<i>Psilostrophe cooperi</i>	<i>Paperflower</i>
<i>Psilostrophe tagetina</i>	<i>Paperflower</i>
<i>Rosmarinus officinalis</i>	<i>Bush Rosemary</i>
<i>Salvia chamaedryoides</i>	<i>Blue Sage</i>
<i>Salvia farinacea</i>	<i>Mealy Cup Sage</i>
<i>Salvia greggii</i>	<i>Texas Red Sage</i>
<i>Santolina chamaecyparissus</i>	<i>Lavender Cotton</i>
<i>Santolina virens</i>	<i>Green Santolina</i>
<i>Senna covesii</i>	<i>Desert Senna</i>
<i>Trixis californica</i>	<i>Trixis</i>
<i>Verbena gooddingii</i>	<i>Goodding's Verbena</i>
<i>Verbena peruviana</i>	<i>Peruvian Verbena</i>
<i>Verbena tenera</i>	<i>Moss Verbena</i>
<i>Verbena rigida</i>	<i>Sandpaper Verbena</i>
<i>Wedelia trilobata</i>	<i>Yellow Dot</i>
<i>Yucca pallida</i>	<i>Plains Yucca</i>
<i>Yucca whipplei</i>	<i>Our Lord's Candle</i>
<i>Zauschneria californica</i>	<i>Hummingbird Flower</i>
<i>Zinnia acerosa</i>	<i>Desert Zinnia</i>
<i>Zinnia grandiflora</i>	<i>Rocky Mountain Zinnia</i>

## **9.3 USE OF PLANT MATERIALS**

### **Originator: Transportation Systems Management & Operations Division**

#### **9.3.1 PRESERVATION OF EXISTING VEGETATION**

In some cases, it may be necessary to maintain existing right-of-way plants in their present location and incorporate them into the final design. The plants to be protected in place will be determined by MCDOT after the inventory and analysis noted in Section 9.1 has been completed. Plants to remain shall meet the clear zone requirements of this Chapter.

#### **9.3.2 PROTECTED PLANTS**

Many native plants in Arizona are protected by law and can only be removed after a permit has been obtained from the Arizona Department of Agriculture, Plant Services Division. The Protected Plant List changes on an occasional basis. Contact Arizona Department of Agriculture (602-542-4373) for the latest Protected Plant List.

#### **9.3.3 PLANT SALVAGE**

On occasion, selected materials (including State-protected plants) will be analyzed for potential salvage and reuse on the project. The analysis will be accomplished using the results of a Plant Inventory as directed by MCDOT during the course of the project. The species to be considered will depend on the project setting. For example, in rural areas, saguaro, barrel cactus and ocotillo may be optimum candidates for transplanting. Within urban areas, existing street trees important to the adjacent neighborhood could be candidates for salvage and reuse.

Several factors must be evaluated when plant salvaging is considered. First, the existing plants must be evaluated for age, health, overall condition and their capability to survive the transplanting operation. Second, the cost of transplanting shall be assessed against the replacement with nursery grown plants of a comparable size; this shall be reviewed in terms of the project budget. Third, other factors such as schedule impacts from salvaging activities, the availability or lack of on-site temporary storage locations, temporary irrigation needs and the importance of the resource to affected local interests shall be evaluated. Based on the above factors, the decision for salvaging will be made by MCDOT.

The construction documents shall state that prior to destroying State-protected plants, the contractor shall file a formal Notice of Intent to Clear Land with the Arizona Department of Agriculture, unless the Notice requirement has been completed during the design phase. The contractor is required to obtain State permits prior to moving protected plants.

#### **9.3.4 RECOMMENDED PLANT LIST AND USE OF TURF GRASS**

In 1987, in an effort to reduce consumption of water by landscaping, the State of Arizona issued a list of plant materials that can be used in the public right-of-way. Since July 1989, Maricopa County has been required to review plans in accordance with the Phoenix AMA (Active

Management Area) List. Projects with landscaping in the right-of-way must use only those plants that are on this list, which is revised on an occasional basis. Per the AMA List, turf grass is not allowed to be planted within the right-of-way. A copy of the AMA Plant List may be obtained from MCDOT or from the Arizona Department of Water Resources.

### **9.3.5 PLANTING RECOMMENDATIONS AND CONSIDERATIONS**

Water use must be minimized by using water conserving plant materials. Since Maricopa County discourages the installation and subsequent maintenance of irrigation systems, low maintenance and drought tolerant plants are highly recommended. Native desert and xeriscape trees and shrubs must be used wherever possible. Exotic plants shall be limited, if used at all.

Existing plant materials in the project area must be taken into consideration to provide design continuity. Impact on adjacent development must be mitigated. The existing landscape character must be evaluated, and landscape expectations obtained from citizens groups and the community. Community identities also shall be enhanced and regional character reinforced through the landscape design. Plant material must be appropriately selected and spaced to maximize visual continuity. The use of distinctive plant materials shall help clue drivers of upcoming intersections and decision points.

Some conditions may be unfavorable to plant growth in an urban area. Drainage conditions may be inadequate; there may be excess drainage or not enough. Air pollution is often a concern. Many plants cannot survive the polluted and dust-laden atmosphere of severe urban conditions. Reflected heat from pavements and adjacent buildings further limits the use of many desirable plants. Only those plants that have proven themselves adaptable to the difficult growing conditions found in some urban situations shall be used in such locations.

Plants shall be used to buffer pedestrians from traffic. The climate for pedestrian comfort can be moderated with shade trees. Trees and shrubs shall be used predominantly, because of their longer life span as compared to groundcovers and herbaceous perennials.

There are specific plant types in and adjacent to the public right-of-way that are not allowed or whose use is not recommended. Trees and shrubs with thorns are to be carefully placed to avoid injury to pedestrians and others using the public right-of-way. Thorny plants must maintain a minimum setback of 4 feet (measured from nearest part of plant) from sidewalks and curbed roadways, and a minimum setback of 7 feet from the edge of bicycle facilities. Whenever possible, thornless varieties shall be used. Table 9.4 contains a listing of plants that will not be approved for planting within the right of way.

Plantings shall be kept a minimum of 7 feet back from the edge of roadway when no vertical curb is present. Plantings shall be kept away from walls and fences to allow for maintenance of those structures.

Trees and shrubs shall be planted so that at maturity they do not interfere with service lines and the property rights of adjacent property owners. The designer shall contact the appropriate utility company to obtain a list of trees acceptable for use over or under their utility lines.

Due to the risks of their falling over and dropping large limbs, trees having shallow root systems

or a weak branch structure shall not be used within 20 feet of the right-of-way limit or traveled way. Trees that have been problematic are: *Eucalyptus rudis*, *Eucalyptus rostrata*, *Eucalyptus polyanthemos*, and *Schinus molle* (California Pepper).

Multiple plant species shall be used to eliminate the hazards of monoculture planting (die-out of large areas of plant material, spread of disease, etc.). Continuous year round color through flowers and foliage shall be featured. Plants which are susceptible to iron chlorosis (Pyracantha, for example) shall be avoided.

The use of plants producing large volumes of wind-blown pollen shall be kept to a minimum. Olive tree use is restricted solely to the use of the swan hill olive (*Olea europaea* "Swan Hill"), which produces minimal pollen and no olives.

TABLE 9.3: PLANTS NOT ALLOWED TO BE PLANTED IN RIGHT OF WAY		
SHRUBS		
Botanical Name	Common Name	Problem Area
Caesalpinia Mexicana	Mexican Bird of Paradise	Maintenance
Caesalpinia Pulcherrima	Red Bird of Paradise	Maintenance
Oleander (all varieties)		Maintenance
Pyracantha		Maintenance
TREES		
Botanical Name	Common Name	Problem Area
Acacia Smallii	Desert Sweet Acacia	Maintenance
Carnegiea Gigantea	Saguaro Cactus	Traffic Hazard
Cercidium Floridum	Blue Palo Verde	Maintenance
Cercidium Praecox	Palo Brea / Sonoran Palo Verde	Maintenance
Eucalyptus (all species)		Traffic Hazard
Forestiera Neomexicana	Desert Olive	Excessive Pollen
Schinus Molle	California Pepper Tree	Traffic Hazard
Vitex Agnus Castus	Chaste Tree	Maintenance
Quercus Viriginiana	Southern Live Oak	Maintenance

### Planting To Screen

#### (a) Headlight Glare

The value of screening for glare depends on road alignment, ground forms, existing vegetation, and the width of the median. Where needed, plantings shall be at least 4 feet high and form a continuous screen, to avoid intermittent glare.

#### (b) Undesirable Views and Objects

An effective method of obscuring undesirable views from and toward the highway is the use of fencing or other structural materials, or by planting. In some cases, effective screening with plants will take a period of years to achieve, but this shall not prevent the use of plants to achieve this objective. The sight lines from and toward the object to be screened shall be studied early in the design process to provide an appropriate solution and to preserve any existing plant material or

structure that will contribute to the screening. Deciduous plant material shall be avoided if a year-round screening effect is desirable.

Vegetation shall not completely encircle lights, signs or other roadside structures; access must be provided for maintenance purposes.

**(c) Wind Control**

In some instances where high winds are characteristic of a particular site, deep-rooting trees with a dense growth habit are beneficial in reducing wind velocity as well as in catching blowing dust and debris. Trees that are weak wooded (such as some Eucalyptus species) shall be avoided in these areas.

**(d) Shade**

Shade effectiveness shall be carefully analyzed. At higher elevations, wherever freezing may be a problem, an east-west orientation of the roadway necessitates a greater offset of vegetation from the south side of the road than the north to prevent shading and ice formation in the wintertime.

**(e) As an Impact Attenuator**

Dense shrub masses, by their slower decelerating effect, cause less damage and injury to car and driver than do solid barriers. However, they may require 2 to 3 years to become firmly rooted and well grown. In the median, multiple rows of dense shrubs are effective, if space is available.

**Planting For Traffic Indication**

Functional planting can help make it evident to the driver that a change in alignment of the road is imminent or that the driver is approaching an intersection. Such planting shall be designed with consideration for traffic safety and low maintenance.

**9.3.6 PLANT DENSITY**

The density of the shrub and ground cover plant material in the median and roadsides is subject to MCDOT approval.

Ground covers shall be used where low plants are desired.

Shrubs shall be spaced at a distance equal to the mature spread of the plant.

**9.3.7 INERT MATERIALS**

Use ¾” or ¾” minus decomposed granite or gravel for landscaping to minimize dust.

Boulders, river cobble or rock products may be used to provide textural contrast, provided the material does not exceed 4 inches in any dimension when located within the clear zone.

A pre-emergent herbicide shall be applied to the ground prior to placement of inert materials, and

again following placement.

Decorative paving (stamped concrete, exposed aggregate concrete, pavers, etc.) may be used for narrow median areas, such as at median noses.

### **9.3.8 LANDSCAPE PLANS**

Planting plans shall be clear and concise and the processes of achieving aesthetic objectives clearly understood. Specifications for nursery stock, planting, seeding, and other types of landscape construction shall be clear, concise, and embody the practice and quality of work best suited for the area. The landscape contractor shall be responsible for the condition of all plants during a specified establishment period. The bid documents shall be set up so that final acceptance and termination of the contract will not occur until expiration of the establishment period.

Landscape plans shall include planting and staking details and a header detail, as well as irrigation details if irrigation is provided.

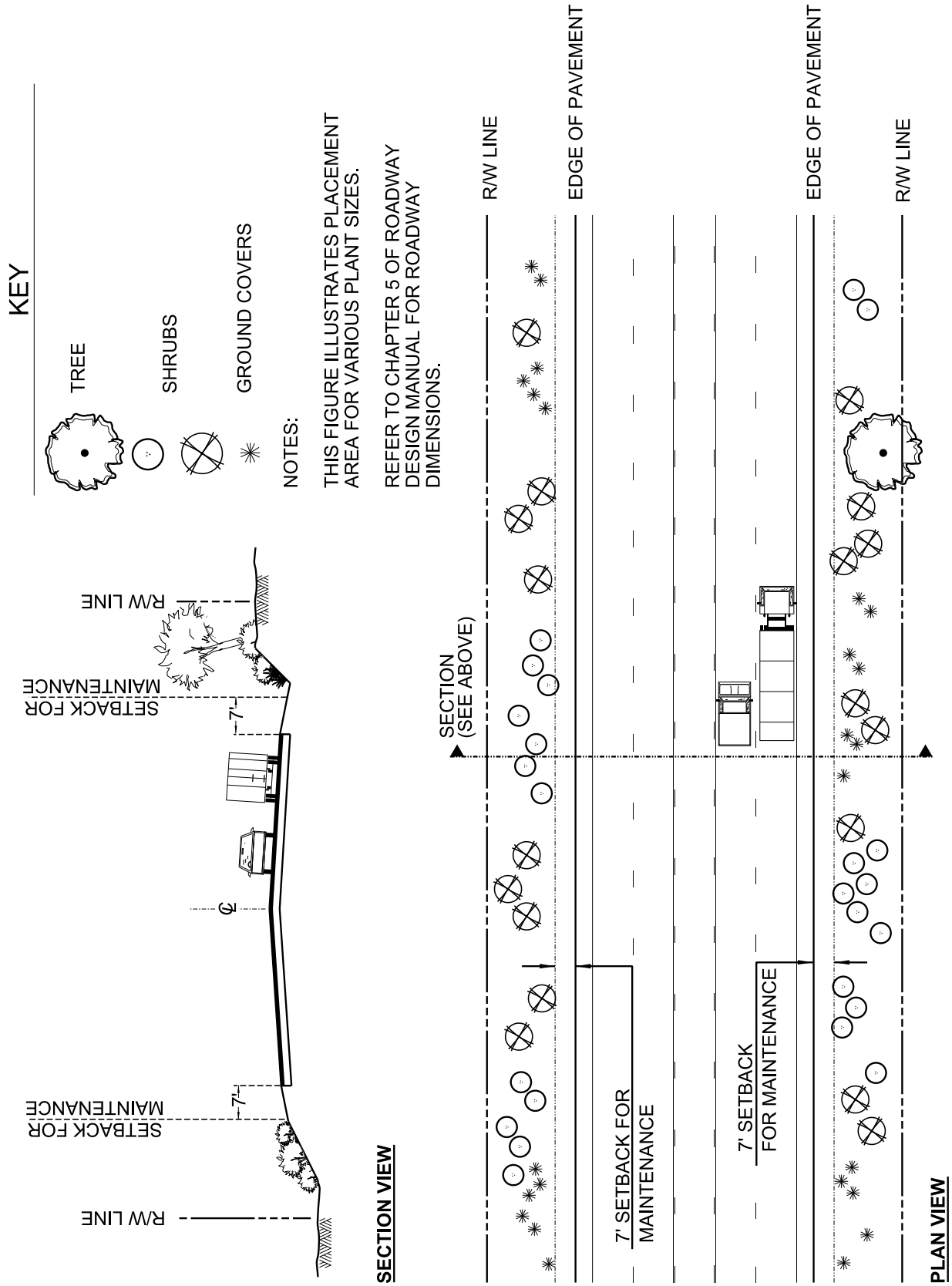
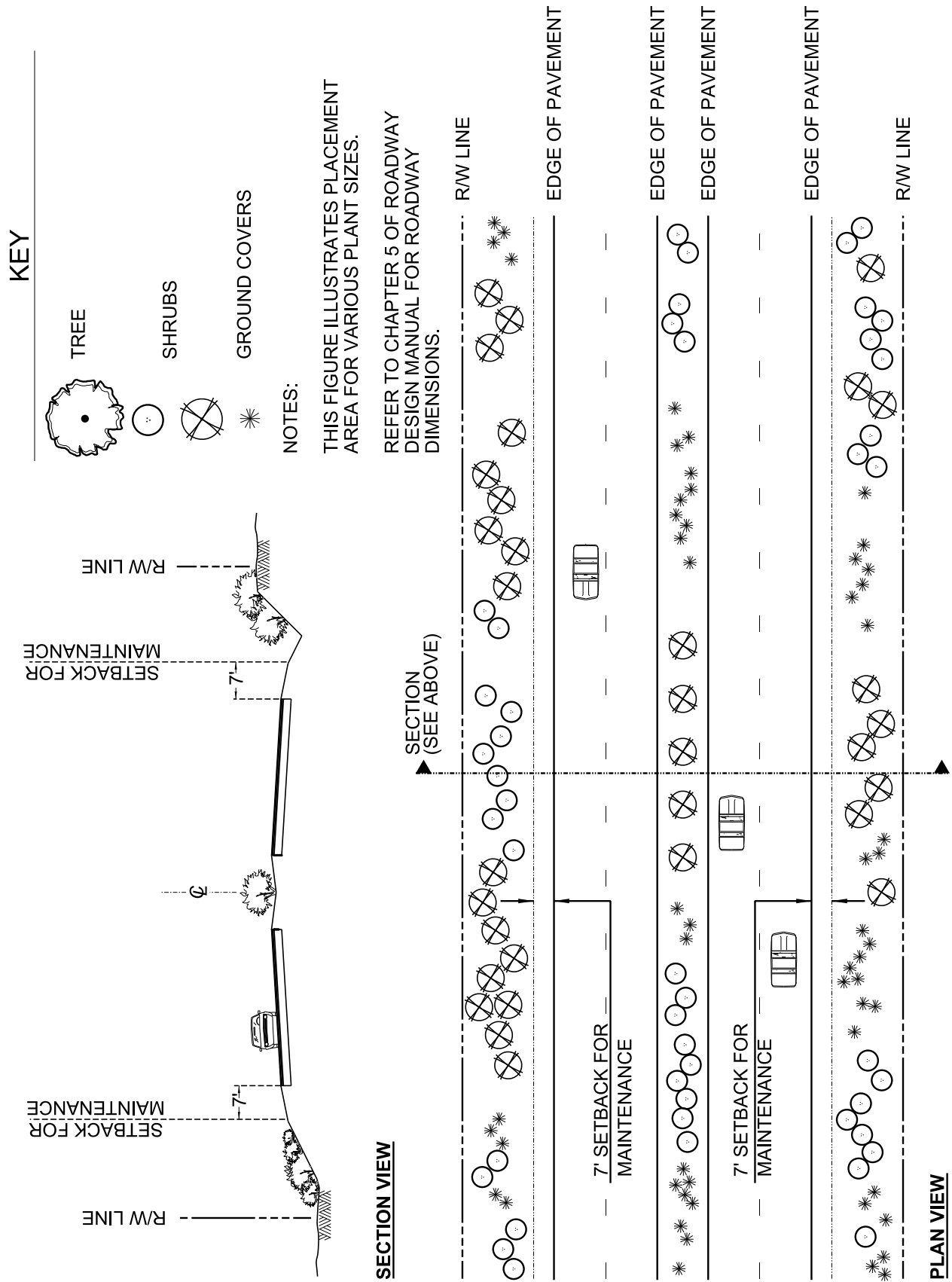


FIGURE 9.4 – RURAL MINOR ARTERIAL ROAD



**FIGURE 9.5 – RURAL PRINCIPAL ARTERIAL ROAD**

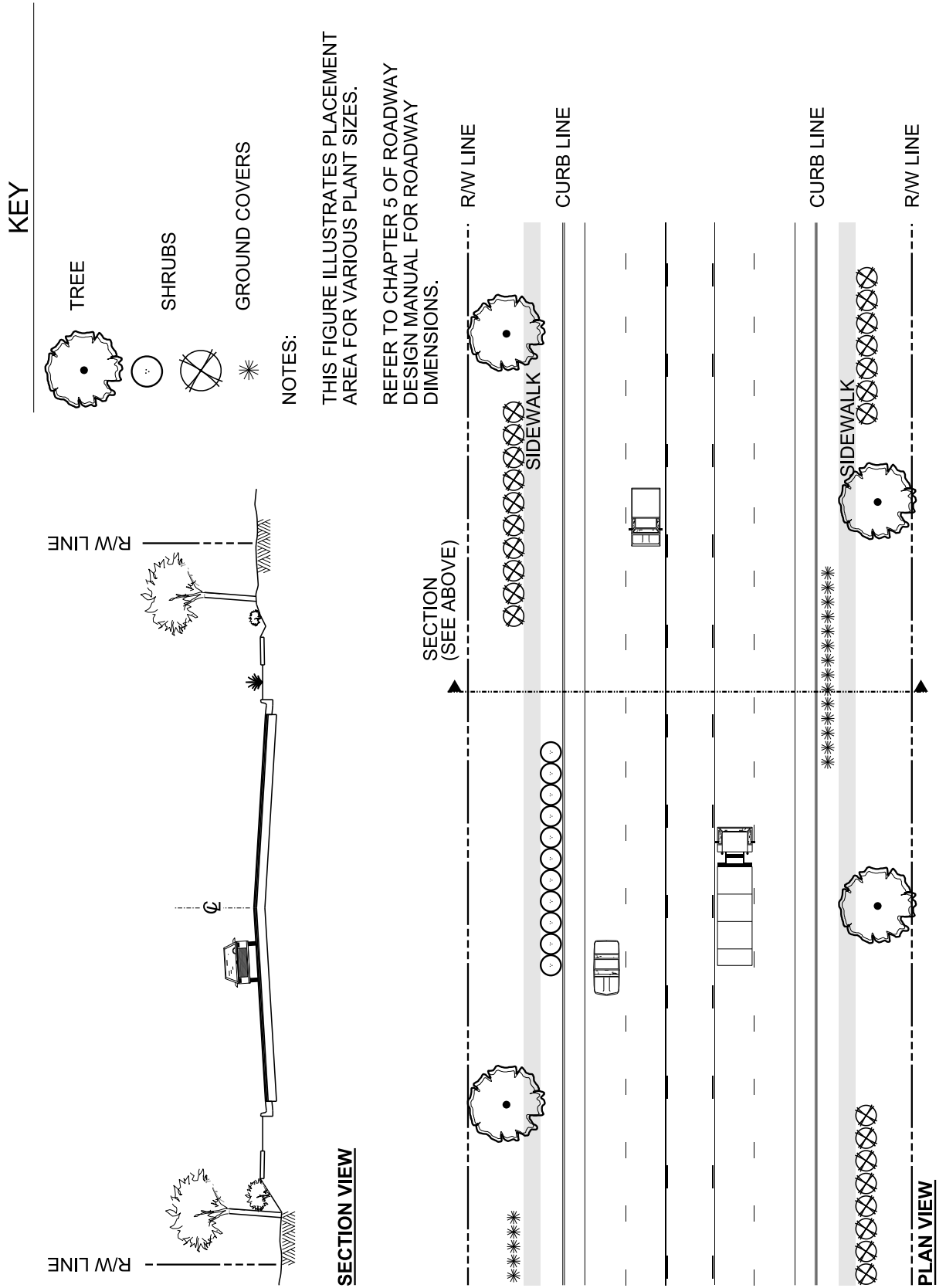


FIGURE 9.6 – URBAN MINOR ARTERIAL ROAD

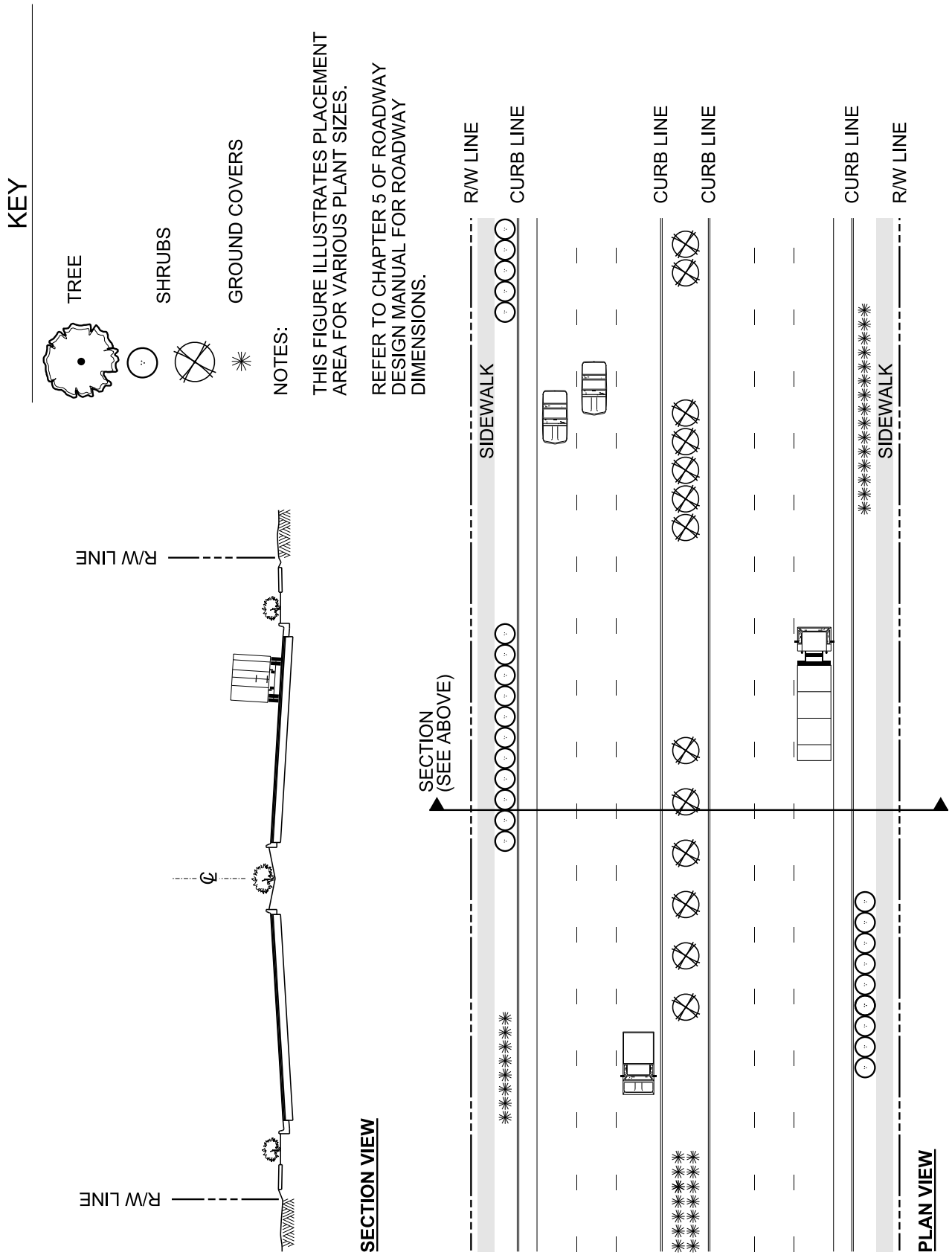


FIGURE 9.7 – URBAN PRINCIPAL ARTERIAL ROAD

## **9.4 MAINTENANCE AND COSTS**

### **Originator: Transportation Systems Management & Operations Division**

#### **9.4.1 CONSIDERATIONS FOR MAINTENANCE:**

- Species,
- Size,
- Location of the plant,
- Accessibility of the plant,
- Susceptibility to insects and disease,
- Fertilization needs,
- Removal and trimming needs (streetlight, traffic sign, signal, or vision obstruction).

Select trees with a naturally high canopy for use within sight triangles to avoid the need for continuous pruning. Trees that create a high quantity of leaf litter, flowers, beans and/or seeds shall be avoided.

Masses shall be placed in “drifts,” arranged to allow access for maintenance and to provide a continuous screen or barrier where desired.

Maximum use shall be made of fast growing shrubs that recover quickly from injury. Slow growers shall be reserved for use as accents.

Landscape plantings shall not encroach onto the roadway or driveway entrances. Landscapes that overhang sidewalks and shared use paths must be maintained so that 10 foot high clearance is provided at all times.

Mature tree growth shall be maintained 6-feet behind the face of the curb line. See Figure 9.3.

#### **9.4.2 VEHICULAR ACCESS**

Vehicular access from the highway or from abutting property is essential for proper maintenance. A clear area for the use of maintenance vehicles shall be located every 2000 feet along each side of the roadway. The maintenance vehicle clear area shall be 15 feet wide and 50 feet long, located at back of curb, where conditions permit. This clear area is in addition to the 7 foot maintenance setback shown in Figures 9.4 and 9.5 for uncurbed roadways.

#### **9.4.3 ROADSIDE MAINTENANCE RESPONSIBILITIES**

Responsibility for maintenance shall be established during the early design stages. Written maintenance agreements shall be developed, or provided if other agencies are involved. Such arrangements will not only prevent jurisdictional problems from after construction but may also affect the design of facilities. Plans must state who is responsible for landscape maintenance. To date, all projects in MCDOT’s jurisdiction, except specified landscaped street medians, are owner

maintained. MCDOT will not assume responsibility for maintenance of any new landscaping. If any plants are installed in County right-of-way, a letter guaranteeing maintenance must be obtained from the party who will assume the future maintenance responsibility. If plants that will require regular irrigation are to be installed, a bond for the amount necessary to return the landscaped area to desert must be posted and remain in effect until:

- The landscaping is returned to low maintenance or existing condition, or
- The area is annexed by a city. If this occurs, the bond will be held until the city notifies MCDOT by letter that bonding requirements for landscaping have been satisfied.

# **Chapter 10**

## **Pavement Design Guide**

**TABLE OF CONTENTS**

**CHAPTER 10 PAVEMENT DESIGN GUIDE**

<b>10.1</b>	<b>COLLECTION OF DATA .....</b>	<b>10-1</b>
10.1.1	OFFICE DATA.....	10-2
10.1.1.1	Cartegraph Operations Management Software.....	10-2
10.1.1.2	Traffic Historical Records.....	10-2
10.1.1.3	Right-of-Way Permits / Jurisdictional Limits.....	10-3
10.1.1.4	ARIZONA 811 (Formerly Arizona Blue Stake, Inc.).....	10-3
10.1.1.5	Project Specific Reports (CAR and SDR) .....	10-3
10.1.2	FIELD DATA .....	10-4
10.1.2.1	Initial Site Visit.....	10-4
10.1.2.2	Field Exploration .....	10-4
<b>10.2</b>	<b>PAVEMENT DESIGN PROCEDURES .....</b>	<b>10-7</b>
10.2.1	DESIGN VARIABLES .....	10-7
10.2.1.1	Analysis Period - 20 years .....	10-7
10.2.1.2	Design Traffic .....	10-8
10.2.1.2.1	Traffic Conversion from Average Daily Traffic (ADT) to Equivalent Single Axle Loads (ESALs) .....	10-9
10.2.1.2.1.1	Determination of Truck Load Factors.....	10-9
10.2.1.2.1.2	Calculate ESALs over the Analysis Period .....	10-12
10.2.1.2.1.3	Traffic in the Design Lane, <b>W18</b> .....	10-13
10.2.1.3	Reliability.....	10-13
10.2.1.4	Performance Criteria (Serviceability).....	10-14
10.2.2	MATERIAL PROPERTIES FOR STRUCTURAL DESIGN.....	10-14
10.2.2.1	Effective Roadbed Soil Resilient Modulus.....	10-14
10.2.2.1.1	Roadbed Soil Resilient Modulus for Flexible Pavement Design .....	10-15
10.2.2.1.1.1	Initial Testing of Sieve Analysis and Plasticity Index .....	10-15
10.2.2.1.1.2	Initial Evaluation of Sieve Analysis and Plasticity Index..	10-15
10.2.2.1.1.3	<i>R - Value</i> Analysis.....	10-16
10.2.2.1.1.4	Local Roads and Roadway Widening.....	10-17
10.2.2.2	Layer Coefficients ( <b>ai</b> ).....	10-18
10.2.3	PAVEMENT STRUCTURAL –DRAINAGE.....	10-19
10.2.4	FLEXIBLE PAVEMENT DESIGN .....	10-20
10.2.4.1	Determining Required Structural Number.....	10-20
10.2.4.2	Selection of Layer Thicknesses .....	10-21
10.2.4.3	Layered Design Analysis .....	10-22
10.2.4.3.1	Construction Constraints for Layer Thickness .....	10-22
10.2.4.4	Expansive and Collapsible Soils.....	10-22
10.2.4.5	Construction Cost Analysis .....	10-23
10.2.5	ALTERNATIVE DESIGN METHOD FOR LOCAL AND MINOR COLLECTOR ROADS .....	10-24
10.2.5.1	Sampling.....	10-24
10.2.5.2	Testing and Design .....	10-24
10.2.6	RIGID PAVEMENT DESIGN .....	10-32

QUICK REFERENCE .....	10-33
<b>10.3 ECONOMIC EVALUATION OF ALTERNATIVE PAVEMENT DESIGN STRATEGIES (LIFE CYCLE COST ANALYSIS).....</b>	<b>10-36</b>
10.3.1 EXAMPLE PAVEMENT DESIGN COST ASSESSMENT FOR PRELIMINARY PAVEMENT DESIGN.....	10-37
10.3.2 EXAMPLE PAVEMENT DESIGN COST ASSESSMENT FOR FINAL DESIGN.....	10-38
<b>10.4 SPECIFICATIONS .....</b>	<b>10-40</b>
<b>10.5 REPORTING REQUIREMENTS.....</b>	<b>10-41</b>
10.5.1 PAVEMENT DESIGN REPORT .....	10-41
10.5.2 OUTLINE OF PAVEMENT DESIGN REPORT.....	10-42
<b>10.6 CHAPTER REFERENCES.....</b>	<b>10-44</b>

**LIST OF FIGURES & DESIGN CHARTS**

FIGURE 1: Maricopa County Map with 500-foot Interval Contour Lines .....	10-1
FIGURE 2: FHWA 13 Vehicle Category Classification .....	10-11
FIGURE 3: Typical Pavement Structure .....	10-18
DESIGN CHART 100A - Depth of Aggregate Base for Minor Collector, Non-Expansive Subgrade .....	10-28
DESIGN CHART 100B - Depth of Aggregate Base for Minor Collector, Expansive Subgrade .....	10-29
DESIGN CHART 200A - Depth of Aggregate Base for Local Roads, Non-Expansive Subgrade .....	10-30
DESIGN CHART 200B - Depth of Aggregate Base for Local Roads, Expansive Subgrade .....	10-31

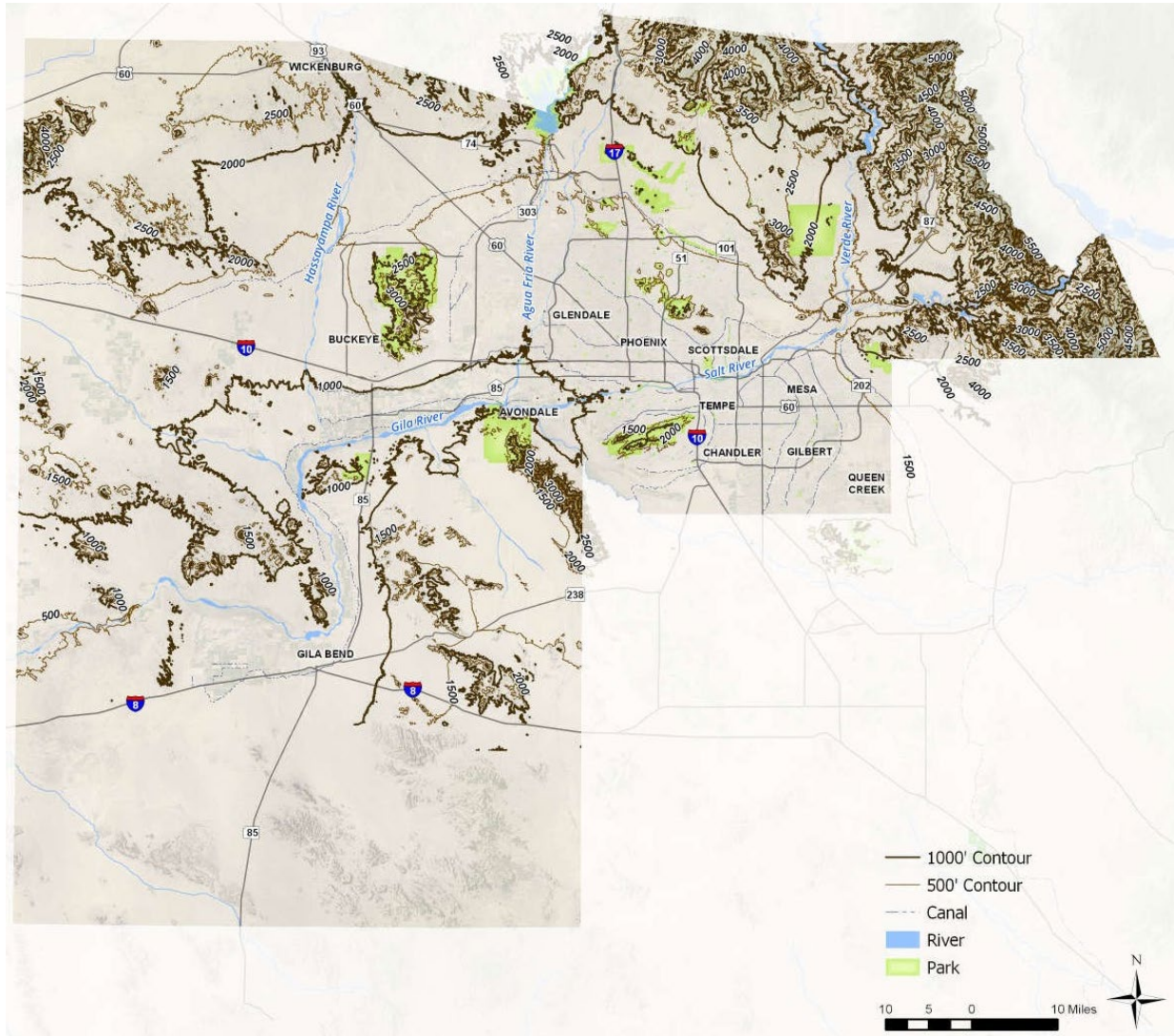
**LIST OF TABLES**

TABLE 10.1.1	Sample Frequency for Pavement Design.....	10-5
TABLE 10.1.2	Example: 2-Mile Long Project – Sample Frequency.....	10-6
TABLE 10.2.1	Sample Frequency for Pavement Design.....	10-9
TABLE 10.2.2	Traffic Equivalency Factors.....	10-10
TABLE 10.2.3	Percent of 18-kip ESALs in Design Lane (DL).....	10-13
TABLE 10.2.4	Level of Reliability (Percent).....	10-14
TABLE 10.2.5	Present Serviceability Index (PSI).....	10-14
TABLE 10.2.6	Structural Layer Coefficient ( $a_i$ ) .....	10-19
TABLE 10.2.7	Drainage Coefficient ( $m_i$ ) .....	10-20
TABLE 10.2.8	Minimum Structural Number Based on Roadway Type.....	10-21
TABLE 10.2.9	Recommended Treatment for Swelling Subgrade Soils .....	10-23
TABLE 10.2.10	Design Charts Summary for Local & Minor Collector Roads .....	10-25
TABLE 10.2.11	Test Data Summary.....	10-26
TABLE 10.2.12	Test Data Summary – With Weighted Average .....	10-27

## 10.1 COLLECTION OF DATA

### **Originator: Construction and Materials Division**

The following methods are to be used for collecting relevant data when designing pavements within the jurisdiction of the Maricopa County Department of Transportation (MCDOT). These methods are appropriate for the desert climates and relatively flat terrain found in most of Maricopa County (See Figure 1).



**FIGURE 1.** Maricopa County Map with 500-foot Interval Contour Lines.

For pavement design work in different climate conditions (more than 2500-foot elevation) and/or projects with significant cuts or fills, procedures in the latest edition of the Arizona Department of Transportation (ADOT) *Pavement Design Manual*<sup>1</sup> are to be followed. The following link provides the access to this manual on ADOT website:

<https://apps.azdot.gov/files/materials-manuals/Preliminary-Engineering-Design/PavementDesignManual.pdf>

Information and data used for the design of pavement structures will need to be collected from historical data (including traffic projections), and from an investigation of the proposed site. The Engineer should collect as much information from the office as is readily available prior to beginning the field investigation. The following sections give guidelines for collecting the data normally available on Maricopa County projects.

**10.1.1 OFFICE DATA**

Historical or planned information on roadways managed by MCDOT can normally be obtained from the Cartegraph Operations Management Software (Cartegraph OMS) database or from the Traffic Engineering section. Coordination with the Right-of-Way section, and ARIZONA 811 is required prior to conducting field investigations. Project specific information can also be found from Candidate Assessment Reports (CARs), Scoping and Design Reports (SDRs), and scopes of work for design consultants.

**10.1.1.1 Cartegraph Operations Management Software**

Cartegraph OMS is MCDOT’s web-based computer software system that stores roadway asset data, including pavement management data. It contains historical information on the pavement condition index (PCI), International Roughness Index (IRI), and Rut Depth Index (RDI), as well as maintenance treatments applied to specific portions of the roadway. It also contains approximated information on the existing pavement sections.

**10.1.1.2 Traffic Historical Records**

Historical records of traffic measurements are maintained by the MCDOT Traffic Engineering Section, and can be accessed online at:

<https://www.maricopa.gov/636/Traffic-Counts>

Traffic count information of other jurisdictions is available on the following websites:

Jurisdiction	Website Address
Chandler	<a href="https://www.chandleraz.gov/residents/transportation/traffic-management/traffic-volumes-and-calming-measures">https://www.chandleraz.gov/residents/transportation/traffic-management/traffic-volumes-and-calming-measures</a>
Gilbert	<a href="http://www.gilbertaz.gov/departments/public-works/engineering-services/traffic-engineering/traffic-counts">http://www.gilbertaz.gov/departments/public-works/engineering-services/traffic-engineering/traffic-counts</a>
Glendale	<a href="http://www.glendaleaz.com/Transportation/TrafficCounts.cfm">http://www.glendaleaz.com/Transportation/TrafficCounts.cfm</a>
Mesa	<a href="https://www.mesaaz.gov/residents/streets-transportation/traffic-counts">https://www.mesaaz.gov/residents/streets-transportation/traffic-counts</a>
Peoria	<a href="https://www.peoriaaz.gov/government/departments/development-and-engineering/traffic-engineering/traffic-counts">https://www.peoriaaz.gov/government/departments/development-and-engineering/traffic-engineering/traffic-counts</a>
Phoenix	<a href="https://www.phoenix.gov/streets/traffic-management/traffic-volume-map">https://www.phoenix.gov/streets/traffic-management/traffic-volume-map</a>
Scottsdale	<a href="http://www.scottsdaleaz.gov/transportation/studies-reports/traffic-volume">http://www.scottsdaleaz.gov/transportation/studies-reports/traffic-volume</a>
Tempe	<a href="https://www.tempe.gov/government/engineering-and-transportation/transportation/streets-signals-traffic/traffic-counts">https://www.tempe.gov/government/engineering-and-transportation/transportation/streets-signals-traffic/traffic-counts</a>

For design and construction of existing major roadways, complete traffic measurements (including vehicle classifications and distribution) are to be used for the pavement design. A knowledgeable and competent traffic engineer shall determine initial traffic volumes, growth rates, truck percentages, operational speed, and axle configuration.

#### **10.1.1.3 Right-of-Way Permits / Jurisdictional Limits**

City limit maps that delineate jurisdictional limits are available on the MCDOT website:

<https://www.maricopa.gov/696/City-Limits>

The maps are provided for your convenience and should only be used as a guide. Determine the correct governing jurisdictions for permits. The permit requirements of the governing jurisdiction shall be followed when collecting field samples.

Maricopa County right-of-way permits are obtained from the MCDOT Permits Section. Many Maricopa County projects are in the city limits of various cities within the county. Project fieldwork shall be done in accordance with the permit requirements of the agency with jurisdiction on the property being investigated. Permission from the owner shall be obtained prior to work on any private property. The pavement designer shall check with the design project manager to determine if permission has been obtained.

#### **10.1.1.4 ARIZONA 811 (Formerly Arizona Blue Stake, Inc.)**

Prior to excavating in any public right-of-way, utilities shall be located by following the procedures of Arizona 811, go to <http://arizona811.com/> or call 811.

In some instances, it may be required to contact the jurisdiction directly in addition to Arizona 811. An example is Salt River Pima Maricopa Indian Community (SRPMIC).

#### **10.1.1.5 Project Specific Reports (CAR and SDR)**

For many projects, much of the information needed for pavement design can be obtained from existing reports. A Candidate Assessment Report (CAR) is often available to a design engineer working on a preliminary pavement design for a Scoping and Design Report (SDR). Reports from paving projects along the roadway are sometimes available for use with preliminary pavement designs.

An SDR report is often available for final pavement design, if a preliminary pavement design is conducted during the scoping phase. It is imperative that the pavement designer reviews the SDR and uses the information in preparing the final pavement sections.

## 10.1.2 FIELD DATA

### 10.1.2.1 Initial Site Visit

During this initial inspection of the project, the design engineer should:

- 1) Determine the scope of the field sampling,
- 2) Begin to assess the potential distress mechanisms for existing pavements, and
- 3) Identify preliminary pavement design alternatives.

As part of this activity, subjective information of distress, road roughness, and moisture/drainage problems should be gathered. Unless traffic volume is a hazard, this data can be collected without any traffic control, through both “windshield” and road shoulder observations. In addition, an initial assessment of traffic control options, obstructions, and safety aspects shall be made during this visit.

The initial site visit has the following impacts on the scope of the subsequent primary field exploration:

- Distress observations may help identify the collection interval, the number of surveyors, and any additional measurement equipment that might be required.
- A general roughness assessment may dictate the need for a more rigorous measurement program to address ride quality related problems such as differential sags or swells.
- Observation of moisture/drainage problems (e.g., standing water on pavement or ditches, settlement at transverse cracks, raveling in non-trafficked areas, and so on) may indicate the need for a more thorough investigation of subsurface drainage conditions.
- Establishment of the sampling plan for the investigation.

### 10.1.2.2 Field Exploration

Field exploration is to be performed after establishment of an initial roadway profile grade.

The essential data collection activities included in this important activity include:

- Distress and drainage surveys
- Observation of land use and geologic features
- Drilling and subsurface geotechnical investigations
- Field sampling and testing

The minimum number of test holes and samples shall be in accordance with Table 10.1.1. Scoping and Design Report (SDR) investigations shall use the “preliminary” sample frequencies. The “final” sample frequencies shall be the minimum sampling acceptable in reports prepared for final design.

The final design shall incorporate the preliminary test results and other previously gathered information. The engineer shall add test holes and samples so that the number of tests accumulated from the preliminary and final investigation achieve the “final” sample frequencies identified in

Table 10.1.1. An example of the tests needed to meet the “final” sample frequencies for a typical two-mile long project is presented in Table 10.1.2.

Field testing for pavement design of roads to be constructed under permit (subdivision roads, etc.) shall be accomplished after final road subgrade elevations have been established and after all underground utilities within the roadway prism have been installed and accepted by the utility owner. Test holes shall be spaced at one (1) per eight hundred (800) lineal feet of road with at least one per proposed street with additional test holes taken at apparent changes in soil type.

<b>TABLE 10.1.1 SAMPLE FREQUENCY FOR PAVEMENT DESIGN</b>		
<b>Test</b>	<b>Number of Samples for Design</b>	
	<b>Preliminary</b>	<b>Final</b>
Sieve & PI	2 per mile (min. of 3)	4 per mile (min. of 3)
R-Value	1 per mile (min. of 3)	2 per mile (min. of 3)
pH & Min. Resistivity	--	1 per culvert location or along metal pipelines <sup>a</sup>
Chloride and sulfate	--	At concrete structure locations <sup>b</sup>
One-dimensional Swell if $PI > 15$ and $P_{200} > 20$	3 per pavement section	
In-place density (sand cone/rings)	Min. of 3 per significant borrow area <sup>c</sup> and per mile of roadway	
Moisture Content (oven)	Min. of 3 per significant borrow area <sup>c</sup> and per mile of roadway	
Proctor Test (D698)	Min. of 3 per significant borrow area <sup>c</sup> and Min. 1 per mile per soil type	
<sup>a</sup> Use for corrugated metal pipe requirements. <sup>b</sup> Use for concrete and reinforcement requirements. <sup>c</sup> Use to estimate shrinkage of borrow areas larger than 5,000 cubic yards and ground compaction in fill areas larger than 50,000 square feet. Borrow areas are on-site excavation areas where the material is generated for fill construction. This may be completed as part of the preliminary or final investigation.		

<b>TABLE 10.1.2 EXAMPLE: TWO-MILE LONG PROJECT WITH LOW PLASTICITY SOILS—SAMPLE FREQUENCY</b>	
<b>Item</b>	<b>Frequency</b>
Borings	8
Sieve Analyses	8
<i>PI</i> s	8
<i>R – Values</i>	4
<i>pH</i> & Min. Resistivity	Same as number of CMP <sup>a</sup> crossings
<sup>a</sup> CMP = Corrugated Metal Pipe	

Each test hole shall be advanced to a depth of at least five feet (5') and extend at least 36 inches below the elevation of the proposed subgrade. In areas of significant cut or fill, the Engineer shall use his professional judgment to determine the depth of each test hole. The test-hole depth is intended to sample and test materials located a minimum of 3 feet below the final roadway's subgrade. Additional test holes shall be taken at apparent changes in soil type.

Coring and sampling of existing pavements is carried out to produce an accurate representation of existing pavement structure. The location of test holes in existing pavements shall be varied to yield samples in the inside and outside lanes and from lanes in both directions. This is especially important in providing design recommendations for rehabilitation or widening projects where the existing pavement may be incorporated into the new structural pavement section.

Sampling frequencies for other tests will be based on specific needs of the project. Percolation testing is required for storm water detention/retention design. Classification type testing (Sieve and PI) is required to address erosion and/or slope stability concerns. Direct shear tests are required to develop foundation design recommendations.

If subgrade soil beneath the designed pavement structure exhibits in-place density described as "loose" to "very loose", one dimensional compression or collapse potential test shall be performed to evaluate the need for over-excavation. In the situation of clayey subgrade soil classified as "soft" to "very soft", compression or consolidation test shall be performed for the same purpose.

## **10.2 PAVEMENT DESIGN PROCEDURES**

### **Originator: Construction and Materials Division**

The American Association of State Highway and Transportation Officials (AASHTO)<sup>2</sup> Guide for Design of Pavement Structures (1993 edition) has been the design standard for asphalt pavement structures in Maricopa County for many years. The County is transitioning its pavement design procedures to follow the new AASHTO Mechanistic-Empirical Pavement Design Guide (MEPDG)<sup>3</sup>. The MCDOT MEPDG will be posted on the Technical page of the MCDOT website (<https://www.maricopa.gov/190/Technical>) and it contains localized factors calibrated for Maricopa County. Starting in October 2019 projects paving at least one-half of an Arterial roadway for a nominal one-half mile length or greater shall have the new pavement designed by both the 1993 AASHTO Guide and the MEPDG program using the MCDOT calibration factors.

The 1993 AASHTO guide presents general design guidance and creates many options for the design engineer. The following sections of these procedures establish MCDOT requirements and guidelines for many of these options. The combination of the 1993 AASHTO guide, the pavement design procedures presented herein, the MEPDG program with MCDOT calibration factors, and the application of professional engineering judgment are required for the design of pavements within Maricopa County. These procedures may not be appropriate for pavement designs in climates that are different than the hot deserts of Maricopa County.

The following sections apply to flexible pavement designs. Concrete pavements shall be designed in accordance with the ADOT Pavement Design Manual<sup>2</sup> and ADOT construction standards, see section 10.2.6.

#### **10.2.1 DESIGN VARIABLES**

##### **10.2.1.1 Analysis Period - 20 years**

AASHTO definition:

*Analysis Period: The period of time for which the analysis is to be conducted; analogous to the term “design life” used by designers in the past. This is the time period used in the AASHTO design equations. (AASHTO, p II-7)<sup>2</sup>.*

An analysis period of 20 years shall be used unless a specific request for a different period is made by the contracting agency. It is recognized that routine maintenance, such as sealing of cracks on a periodic basis, will be necessary during the life of the pavement, and that rehabilitation of the pavement surface may be needed before 20 years due to destructive climatic effects and deteriorating effects of normal use.

For analysis periods less than 20 years, the designer shall be mindful of the fact that the analysis period is not synonymous with “how long the pavement will last”. At least not in terms of the layman’s understanding of how long a pavement will last. One should keep in mind that a substantial percentage of pavements do not achieve more than one-half of their analysis period before significant maintenance work is required.

Temporary pavements are often used on roadway construction projects. Examples of these are detour roads and lower lifts of pavement that are opened to traffic before the final lifts are completed. Any time the pavement will be temporarily exposed to traffic (less than 6 months), the pavement shall have a thickness representing a 4-year analysis period as a minimum. This means the pavement designer is to perform a 4-year design with the project traffic, and make a recommendation for the asphalt thickness that must be placed before traffic is allowed on the pavement.

As an example, if a 20-year design requires 7 inches of asphalt concrete, and a 4-year design requires 5 inches of asphalt concrete, the contractor shall not be allowed to place traffic on the pavement until at least 5 inches of asphalt concrete has been placed. This is to protect the new pavement from significant damage during construction.

#### **10.2.1.2 Design Traffic**

Design traffic will be considered on the basis of cumulative 18-kip equivalent single axle loads (ESALs) during the analysis period. Traffic data will generally come from one or more of the following three sources:

- Maricopa Association of Governments (MAG) traffic projections.
- Traffic studies provided for the project. These are generally presented in the SDR or other design documents for the project.
- Scope of work (for design consultants).

Table 10.2.1 summarizes the steps in calculating the design ESALs ( $W_{18}$ ), and then calculating the desired structural number for a project. Note: Refer to the respective sections that follows this table for the meaning of symbols and more detailed steps.

<b>TABLE 10.2.1 STEPS IN CALCULATING THE DESIGN ESALS (<math>W_{18}</math>) AND STRUCTURAL NUMBER (SN)</b>	
<b>Step</b>	<b>Calculation</b>
Initial Traffic Data	Obtain two-way <b>ADT</b> , traffic growth rate ( <b>g</b> ), and Truck Percentage ( <b>T</b> )
Initial two-way daily traffic, measured in terms of 18-kip ESALs [ $W_{0(2-18)}$ ]	$W_{0(2-18)} = \sum_{i=1}^k N_i TEF_i = N_1 TEF_1 + N_2 TEF_2 + \dots + N_k TEF_k$ Use if traffic classification data is available. Otherwise, use the simplified formula given on the next step.
Alternatively, use standard Traffic Equivalent Factor (TEF = 1.2) to calculate $W_{0(2-18)}$	$W_{0(2-18)} = (ADT \times \% \text{ Cars} \times 0.0008) + (ADT \times T \times 1.2)$
Calculate Overall Growth Factor (OGF)	$OGF = \frac{(1 + g)^n - 1}{g}$ , where $n = 20$ years for most of the cases & $n = 4$ for temporary pavements
Calculate Two-way 18-kip ESALs for the analysis period ( $W_{2-18}$ )	$W_{2-18} = 365 \times OGF \times W_{0(2-18)}$
Determine the traffic in the design lane ( $W_{18}$ )	$W_{18} = W_{2-18} \times D_D \times D_L$ , where $D_D$ = directional distribution factor & $D_L$ = lane distribution factor
Determine the desired Structural Number (SN)	$\log_{10}(W_{18}) = Z_R S_0 + 9.36 \log_{10}(SN + 1) - 0.2 + \frac{\log_{10} \left( \frac{\Delta_{PSI}}{4.2 - 1.5} \right)}{0.40 + \frac{1094}{(SN + 1)^{5.19}}} + 2.32 \log_{10}(M_R) - 8.07$ See Section 10.2.4.1 for details.

**10.2.1.2.1 Traffic Conversion from Average Daily Traffic (ADT) to Equivalent Single Axle Loads (ESALs)**

The purpose of this procedure is to convert the traffic data, which is collected from traffic counts, into 18-kip Equivalent Single Axle Loads (ESALs). Pavement designers generally receive traffic information in the form of average daily traffic (ADT) or get printed lists of vehicle counts for a given period of time. MCDOT’s Traffic Engineering Section generally measures traffic for two 24-hour periods and will report the numbers of vehicles per day. They have two methods of counting. One counts total vehicles, and the other separates vehicle counts by classification and report the truck percentage. Procedures presented in this manual can accommodate either of the methods of counting traffic. Note: In addition to ADT and classification counts, if operational speed and axle configuration are available, they can be used as MEPDG design inputs.

**10.2.1.2.1.1 Determination of Truck Load Factors**

The preferred method is to use traffic data that includes all 13 of the vehicle classifications (Method 1): this data is to be used unless otherwise authorized by MCDOT. If classification counts are not available, an alternate method for estimating traffic impact is presented in the paragraph titled Method 2: using the **Standard Traffic Factor for Heavy Trucks—Class ≥ 4**

**Method 1: Using Traffic Factors for All Classifications**

This method is the same as that presented in Appendix D of the 1993 AASHTO guide<sup>2</sup>. A traffic equivalency factor is assigned to each of 13 vehicle classifications. The equivalency factors given on Table 10.2.2 are to be used.

<b>Class</b>	<b>Federal Highway Administration (FHWA) Description (Figure 2)</b>	<b>Traffic Equivalency Factor (TEF)</b>	<b>TEF for Method 2</b>
1	Motorcycles	0	
2	Passenger Cars	0.0008	0.0008
3	Four Tire, Single Units	0.0122	
4	Buses	0.6806	1.2
5	Two-Axle, Six-Tire, Single-Unit Trucks	0.1890	
6	Three-Axle Single-Unit Trucks	0.1303	
7	Four or More Axle Single-Unit Trucks	0.1303	
8	Four or Fewer Axle Single-Trailer Trucks	0.8646	
9	Five-Axle Single-Trailer Trucks	2.3719	
10	Six or More Axle Single-Trailer Trucks	2.3719	
11	Five or Fewer Axle Multi-Trailer Trucks	2.3187	
12	Six-Axle Multi-Trailer Trucks	2.3187	
13	Seven or More Axle Multi-Trailer Trucks	2.3187	

Initial two-way daily traffic, measured in terms of 18-kip ESALs ( $W_{0(2-18)}$ ) can then be determined by multiplying the daily number of vehicles in that classification times their corresponding equivalency factors and adding them all together. The following formula can be used:

$$W_{0(2-18)} = \sum_{i=1}^k N_i TEF_i = N_1 TEF_1 + N_2 TEF_2 + \dots + N_k TEF_k$$

Where,

$W_{0(2-18)}$  = Initial 2-way daily 18-kip ESALs





























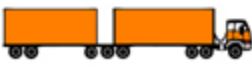




k = number of vehicle classifications considered

$N_i$  = Number of vehicles per day of a given classification

$TEF_i$  = Traffic Equivalency Factor for the given classification from Table 10.2.2

The initial two-way daily traffic is intended to represent the daily average traffic level in the first year the pavement is put into service. The traffic will usually increase from that point, at the selected growth rate, until it achieves the total number of ESALs at the end of the analysis period.

Figure 2. FHWA 13 Vehicle Category Classification.

<b>Class 1</b> Motorcycles		<b>Class 7</b> Four or more axle, single unit	
<b>Class 2</b> Passenger cars		<b>Class 8</b> Four or less axle, single trailer	
			
			
			
<b>Class 3</b> Four tire, single unit		<b>Class 9</b> 5-Axle tractor semitrailer	
			
			
<b>Class 4</b> Buses		<b>Class 10</b> Six or more axle, single trailer	
			
			<b>Class 11</b> Five or less axle, multi trailer
<b>Class 5</b> Two axle, six tire, single unit		<b>Class 12</b> Six axle, multi-trailer	
			
		<b>Class 13</b> Seven or more axle, multi-trailer	
			
			
			

**Method 2: Using Standard Traffic Factor for Heavy Trucks—Class ≥ 4**

If vehicle classification data is not available in sufficient detail to use the 13 classifications described above, a traffic equivalency factor of 1.2 shall be applied to the percentage of vehicles considered to be heavy trucks. This is based on the “approximation” method developed in the ADOT Pavement Design Manual<sup>1</sup>. The remaining percentage of vehicles is considered to be cars. The designer shall then proceed as above except that there would only be two classifications, cars and heavy trucks. Cars are assigned a 0.0008 factor and heavy trucks are assigned a factor of 1.2 (See Table 10.2.2). The following formula shall be used to calculate the average two-way daily traffic,  $W_{0(2-18)}$ .

$$W_{0(2-18)} = (ADT \times \% \text{ Cars} \times 0.0008) + (ADT \times T \times 1.2)$$

Where,

- ADT = Average (two way) Daily Traffic
- $W_{0(2-18)}$  = Initial two-way daily 18-kip ESALs
- T = Percent All Trucks  $\geq$  Class 4 in Table 10.2.2
- % Cars =  $1 - T$

### 10.2.1.2.1.2 Calculate ESALs over the Analysis Period

To complete the traffic conversion, the designer must calculate the amount of traffic over the entire analysis period, and apply a growth factor.

Annual growth rates should be supplied by traffic engineering for each project. Traffic in the growing areas of Maricopa County has experienced growth in the range of 4% to 8% in recent years. More mature areas experience less growth (in the range of 0% to 4%). The designer should recognize the significance of this factor on the design. Growth rates are one of the most influential factors in the final thickness of the pavement, and they should be estimated as accurately as possible.

The following equation can be used to calculate an overall growth factor (OGF) based on annual growth rates.

$$OGF = \frac{(1 + g)^n - 1}{g}$$

Where,

- $g$  = annual growth rate as a decimal number (i.e. use 0.05 in the equation for  $g = 5\%$ )
- $n$  = number of years in the analysis period

This growth factor will have to be multiplied times the number of ESALs expected for the first year ( $365 \times OGF$ ) to calculate  $W_{2-18}$ .

$$W_{2-18} = 365 \times OGF \times W_{0(2-18)}$$

Where,

- $W_{0(2-18)}$  = Initial two-way 18-kip ESALs
- OGF = Overall Growth Factor
- 365 = Number of days per year
- $W_{2-18}$  = Two-way 18-kip ESALs for the analysis period

This number ( $W_{2-18}$ ) will then need to be reduced for directional and lane distribution as described in the following section.

**10.2.1.2.1.3 Traffic in the Design Lane,  $W_{18}$**

The following equation shall be used to determine the traffic ( $W_{18}$ ) in the design lane:

$$W_{18} = W_{2-18} \times D_D \times D_L$$

Where:

$W_{18}$  = the cumulative 18-kip ESAL units predicted for the design lane during the analysis period. The pavement design is based on this number.

$D_D$  = a directional distribution factor, expressed as a ratio, that accounts for the distribution of ESAL units by direction, e.g., Eastbound, Northbound, etc.

$D_L$  = a lane distribution factor, expressed as a ratio, that accounts for distribution of traffic when two or more lanes are available in one direction, and

$W_{2-18}$  = the cumulative two-directional 18 kip ESAL units predicted for a specific section of highway during the analysis period (from the traffic data). Note: See Section 10.2.1.2.1.2.

Although the directional distribution factor ( $D_D$ ) is 50% for most roadways, there are instances where more weight may be moving in one direction than the other. An example of this is roadways leading to mine sites and/or aggregate suppliers. The side with heavier vehicles is used for the design or is separated out and designed for a greater number of ESALs. Experience has shown that  $D_D$  may vary from 0.5 to 0.7.

For the lane distribution factor ( $D_L$ ), use Table 10.2.3 unless specific information to the contrary is known about the project:

<b>TABLE 10.2.3 PERCENT OF 18-KIP ESALS IN DESIGN LANE (<math>D_L</math>)</b>	
Number of Lanes in Each Direction	Percent of 18-kip ESALs in Design Lane ( $D_L$ )
1	100
2	90
3	70
4	60

**10.2.1.3 Reliability**

Reliability concepts are used in pavement design to consider the likelihood that the design will achieve its performance criteria. It is necessary to apply these statistical concepts because of the variability of input parameters such as traffic prediction, performance prediction, materials, and construction practices. Reliability concepts are incorporated into pavement design using two statistical parameters. Those parameters are Level of Reliability and Overall Standard Deviation ( $S_0$ ).

The following levels of reliability (Table 10.2.4) and overall standard deviation shall be used for pavement designs in Maricopa County. Corresponding values of the standard normal random variable ( $Z_R$ ) are also presented for assistance in design calculations as needed.

<b>TABLE 10.2.4 LEVEL OF RELIABILITY</b>			
<b>Functional Classification *</b>	<b>Reliability</b>	<b><math>Z_R</math> Value</b>	<b>Std. Dev. (<math>S_0</math>)</b>
Highways and Parkways	95 %	-1.645	0.45
Arterials & Industrial	95 %	-1.645	0.45
Collectors	90 %	-1.282	0.45
Residential (Local)	80 %	-0.841	0.45
* See Chapter 2 for Functional Classification Definitions.			

**10.2.1.4 Performance Criteria (Serviceability)**

The Present Serviceability Index ( $PSI$ ) is the performance criterion for flexible pavement design. A pavement’s  $PSI$  can range from 0 (impossible road) to 5 (perfect road). The values in Table 10.2.5 shall be used for Initial Serviceability ( $P_0$ ), Terminal Serviceability ( $P_t$ ), and Change in Serviceability ( $\Delta_{PSI}$ ).

<b>TABLE 10.2.5 PRESENT SERVICEABILITY INDEX (<math>PSI</math>)</b>			
<b>Functional Classification *</b>	<b><math>P_0</math></b>	<b><math>P_t</math></b>	<b><math>\Delta_{PSI}</math></b>
Highways and Parkways	4.6	2.7	1.9
Arterials & Industrial	4.5	2.5	2.0
Collectors	4.4	2.3	2.1
Residential (Local)	4.2	2.0	2.2
* See Chapter 2 to determine Functional Classification.			

**10.2.2 MATERIAL PROPERTIES FOR STRUCTURAL DESIGN**

**10.2.2.1 Effective Roadbed Soil Resilient Modulus**

Required thickness and strength for the pavement is heavily influenced by the quality of the roadbed soil (subgrade). The measure of “quality” of roadbed soil is defined by AASHTO as the soil resilient modulus ( $M_R$ ). Because of the difficulty and expense to measure  $M_R$  directly, the quality of roadbed soil in Maricopa County will be determined with measured and correlated R-values converted to resilient modulus. The MCDOT method for developing roadbed soil resilient modulus is presented below in Section 10.2.2.1.1.

The 1993 AASHTO guide provides a method to evaluate the resilient modulus in various moisture states representing different seasons of the year. Because of the relatively low effect of seasons on the condition of subgrade soils in the deserts of Arizona, that procedure will not be required for MCDOT projects. A single design value of resilient modulus can be used for the pavement design.

An option for using sieve analysis and plasticity index (PI) to evaluate the roadbed soil is available for local and minor collector roadways. This method uses charts where the Percent Passing the No. 200 Sieve ( $P_{200}$ ) and PI are plotted and used to select the needed base course thickness. This

chart method is presented in Section 10.2.5. The charts are NOT appropriate for roadways other than local and minor collectors.

**10.2.2.1.1 Roadbed Soil Resilient Modulus for Flexible Pavement Design**

Roadbed soil resilient modulus is a required input for flexible pavement designs. It can be estimated from R-value test results of subgrade soils. On large projects, many R-values would be necessary to acquire enough tests to adequately represent the subgrade soils on the project. To reduce cost and time in acquiring so many R-values, the ADOT has developed a method to combine measured R-values with correlated R-values (using PI and  $P_{200}$  results). The procedures presented here are modifications of those developed by the ADOT as presented in their Pavement Design Manual<sup>1</sup>.

**10.2.2.1.1.1 Initial Testing of Sieve Analysis and Plasticity Index**

The first step is to sample and test the subgrade at the specified frequency. After the design engineer has completed a field reconnaissance, samples are to be taken such that all of the soil types anticipated in the pavement subgrade are represented. Sufficient soil shall be obtained in each sample to test sieve analysis (sieve), plasticity index (PI), expansion, R-value, and any other test the pavement designer deems appropriate for the needs of that specific project. The samples are to be returned to the laboratory and each sample shall be tested for sieve and PI. The representative remnants of each sample shall be held in the laboratory until they are assigned for other testing, including R-value, expansion, pH, and resistivity testing.

**10.2.2.1.1.2 Initial Evaluation of Sieve Analysis and Plasticity Index**

The sieve and PI test results are then used to calculate correlated R-values ( $R_{cor}$ ) using the following equations:

$$SPF = 2.05 - 0.0033 P_{200} - 0.017 PI$$

$$R_{cor} = 0.018e^{SPF/0.235} + 6.0$$

$$\text{If } R_{cor} > 70, \text{ set } R_{cor} = 70$$

Where,

$PI$  = Plasticity Index

$P_{200}$  = Percentage Passing No. 200 Sieve from the sieve analysis

$SPF$  = Sieve and  $PI$  factor

Note: This equation for correlated  $R$  – value is a variation of that presented in the ADOT Pavement Design Manual<sup>1</sup>. The equation has been adjusted to represent soils typical to Maricopa County, whereas the ADOT equation is for soils throughout the state of Arizona.

A table of test results and corresponding R-value estimates is then prepared. This table includes the average and standard deviation of the correlated R-values for the project. If the standard deviation of the R-values is high (i.e. greater than 10), the design engineer shall review the project and site conditions to see if the project should be divided into multiple segments to accommodate

different pavement sections. If more than one segment is warranted, then a correlated R-value table shall be prepared for each segment. A separate table is not necessary for pavement sections designed using the same subgrade resilient modulus.

Selection of which subgrade samples will be tested for R-value is made after reviewing the correlated R-value table. The samples shall be selected such that R-values will be measured from the full range of correlated R-values on the project. The number of R-values tested should be about ½ the number of subgrade sieve and PI results. This means that only half of the held samples in the laboratory would be used. However, a minimum of 3 measured R-values is required for each project or each segment of a project.

**EXCEPTION:** If the average correlated R-value is 50 or greater and the standard deviation is less than 10, it is not necessary to run any R-values. The mean R-value can be calculated from the correlated values.

The pavement designer may elect to select samples for R-value testing based on visual descriptions of the soils prior to sieve and PI testing in order to save time. This will be considered acceptable if the engineer’s judgment and visual classification skills are sufficient to accomplish the intent of the selection process. If the criteria of the selection process are not met, additional samples shall be tested to establish a reasonably accurate understanding of the subgrade modulus.

**10.2.2.1.1.3      R – Value Analysis**

After the selected R-value tests are completed, the results shall be added to the correlated R-value table for analysis. Average and standard deviation values for measured R-values shall be made separate from those for the correlated R-values.

The pavement designer reviews the average and standard deviation values of both measured and correlated R-values to make the final decision about recommending different segments. Again, separate summary tables are to be prepared for each segment of work (different subgrade) if different subgrade resilient modulus ( $M_R$ ) values are used.

**Adjustment for Highly Variable Soil Conditions**

If the standard deviation of either correlated or measured R-value is greater than 10, an adjusted average value shall be calculated to reduce the value by the amount in excess of 10. No adjustment should be made if the standard deviation is less than 10. For Example:

$$\begin{aligned} \text{Average R – value} &= 27 \\ \text{Standard Deviation} &= 13 \\ \text{Adjusted Average R – value} &= 27 - (13 - 10) = 24 \end{aligned}$$

**Calculate Mean R-Value**

A mean R-value is then calculated using the following equation:

$$R_{mean} = \frac{2N_t R_t SD_c^2 + N_c R_c SD_t^2}{2N_t SD_c^2 + N_c SD_t^2}$$

Where,

- $N_t$  = number of measured *R – values*
- $N_c$  = number of correlated *R – values*
- $R_t$  = adjusted average of the measured *R – values*
- $R_c$  = adjusted average of the correlated *R – values*
- $SD_t$  = standard deviation of the measured *R – values*
- $SD_c$  = standard deviation of the correlated *R – values*

The mean R-value is then used to calculate the subgrade soil resilient modulus ( $M_R$ ) using the equation presented below. If the calculated subgrade soil resilient modulus is greater than 26,000 psi, the value used for design purposes shall be 26,000 psi.

$$M_R = \frac{(1815 + 225 R_{mean} + 2.40 R_{mean}^2)}{0.6 SVF^{0.6}}$$

Where,

- $M_R$  = Subgrade Soil Resilient Modulus in pounds per square inch (psi)
- $SVF$  = Seasonal Variation Factor (use 1.0 for Maricopa County)
- $R_{mean}$  = Mean *R – value* as calculated above

This subgrade soil resilient modulus ( $M_R$ ) can then be used in the flexible pavement design portion of this guide to calculate the structural number (SN) that the pavement should provide.

#### 10.2.2.1.1.4 Local Roads and Roadway Widening

There are two conditions for which a pavement design can be performed without using the procedures presented above for determining subgrade soil resilient modulus. For these two conditions, the designer will use *Sieve* and *PI* test results on simple design charts, or use correlated R-values without any tested R-values.

##### **Condition 1:**

The first condition is for local residential and minor collector streets where lower reliabilities are allowed. On these roadways, it may be more useful for the designer to have many *Sieve* and *PI* results to identify changes in subgrade verses more accurate *R – value* tests in fewer locations. See Section 10.2.6 (Alternative Design Method for Local and Minor Collector Roads) for designing local and minor collector streets based on *PI* and  $P_{200}$ .

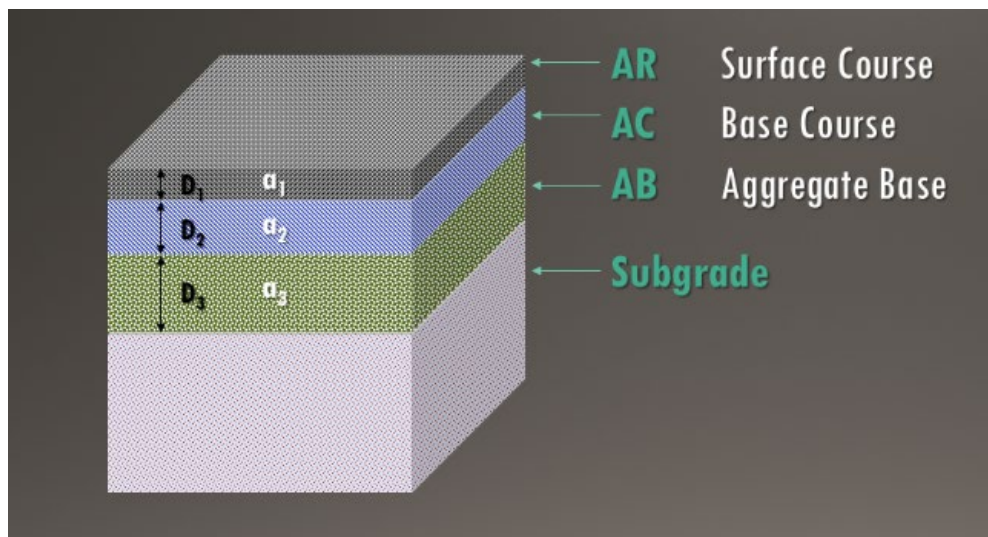
##### **Condition 2:**

The second condition uses only correlated R-values for short sections (1,000 feet or less) of roadway widening or other projects where minor additions are being made to an existing pavement. For these projects, the designer shall perform a pavement condition survey on the existing pavement and evaluate the performance of the structural section under the loading up to that point

in time. Consideration should be given to match the existing section unless it has not performed sufficiently or if traffic has increased or is expected to increase.

### 10.2.2.2 Layer Coefficients ( $a_i$ )

The final pavement will typically be comprised of more than one layer of different materials (See Figure 3). A simple flexible pavement structure is comprised of asphalt concrete (AC) and aggregate base (AB) course (2 layers). The number of layers will be three if asphalt rubber (AR) is used as the surface course (Figure 3). Each layer is assigned a structural layer coefficient ( $a_i$ ) by the designer. This coefficient is used to convert actual layer thickness into a structural number (SN). Higher coefficients represent more contribution (per inch) to the structural capacity and longevity of the pavement. These coefficients will be used in the structural design formula presented in the “Selection of Layer Thicknesses” section below. The layer coefficients in Table 10.2.6 shall be used.



**Figure 3.** Typical Pavement Structure.

**TABLE 10.2.6 STRUCTURAL LAYER COEFFICIENT ( $a_i$ )**

<b>Material Description</b>	<b>Structural Layer Coefficient, <math>a_i</math></b>	<b>Thickness Constraint</b>
Asphalt Rubber Asphalt Concrete (ARAC)	0.42 <sup>a</sup>	Minimum 1.5 in. <sup>b</sup> Maximum 2.0 in. <sup>c</sup>
Asphalt Concrete (AC)	0.42	Based on Layered Analysis
Cement Treated Base (CTB)	0.28	Minimum 4.0 in.
Aggregate Base (AB)	0.12	Minimum 4.0 in.
MAG Select	0.11	Minimum 4.0 in.
Stabilized Subgrade	0.16 to 0.23 <sup>d</sup>	Minimum 6.0 in.

<sup>a</sup> In order to consider the superior performance in resistance to cracking and other aging characteristics, a structural layer coefficient of 0.61 may be used for ARAC (MAG Sections 325 and 717) only for 1.5-inch thickness, when used as a surface course on top of 3 inches or greater of conventional asphalt pavement (MAG Sections 321 and 710).

<sup>b</sup> Minimum thickness can be reduced to 1.0 inch for hot-in-place recycling (HIPR) pavement construction.

<sup>c</sup> In rare cases, when using 2 inches of ARAC, structural layer coefficient of 0.61 can be used for the top 1.5 inches. The bottom 0.5 inches should use 0.42 coefficient provided that the base course meets the 3-inch minimum requirement.

<sup>d</sup> The coefficient for stabilized subgrade is to be determined using a non-soaked 7-day compressive strength, using ASTM D1633 Method A, and the following formula:

$$a_i = 0.15 + 0.0001 (\text{CSCLS})$$

Where: CSCLS = Compressive strength of cement or lime stabilized subgrade in psi.

<sup>e</sup> Except for ARAC mixes, all other AC mixes shall be Superpave/Gyratory type unless approved by MCDOT. AC mix design used on local and minor collector streets shall be for low traffic condition. AC pavement lift thickness shall be at least three times the nominal size of the AC mix. The nominal size designation for the surface course on urban roadways shall be a ½” mix, unless approved by MCDOT.

### 10.2.3 PAVEMENT STRUCTURAL –DRAINAGE

The capability of a roadway to shed water is another factor in roadway and pavement design. The pavement designer must select a drainage coefficient ( $m_i$ ) to represent the effects of the drainage quality on the needed pavement structure. This coefficient is related to the quality of the roadway’s drainage (i.e. how long before water is removed) and the anticipated percent of time the pavement structure is exposed to moisture levels approaching saturation.

If the pavement designer does not consider this factor, they are automatically considering the drainage coefficient to be 1.00, an inaccurate value for some roadways in Maricopa County. The ADOT has developed drainage coefficients throughout the state based on AASHTO guidelines and their experience. The ADOT method relates drainage coefficients to an Arizona map that establishes zones of seasonal variations. Drainage coefficients using the ADOT method for Maricopa County are presented in Table 10.2.7 and shall be used for MCDOT designs. Table 10.2.7 also presents the AASHTO criteria for establishing drainage quality based on the time needed for water to be removed from the pavement.

<b>TABLE 10.2.7 DRAINAGE COEFFICIENT (m<sub>i</sub>)</b>		
<b>Drainage Quality</b>	<b>Drainage Coefficient ADOT<sup>1</sup></b>	<b>Water Removed Within AASHTO<sup>2</sup>, page II-22</b>
Excellent	1.15	2 hours
Good	1.07	1 day
Fair	1.00	1 week
Poor	0.93	1 month
Very Poor	0.86	Water will not drain

Highways elevated two feet or more above the adjacent ground surface, having a minimum crowned cross slope of 2.0%, and a graded shoulder carrying water 10 feet or more away from the outside edge of the outside lane shall be considered to have “good” drainage. Roadways designed with concrete curbs and drop inlet drainage meeting MCDOT standards shall be considered to have “fair” drainage, and a drainage coefficient of 1.00 is recommended.

**10.2.4 FLEXIBLE PAVEMENT DESIGN**

After determining the selected parameters for design variables, performance criteria, material properties, and drainage, proceed through the AASHTO design equations to determine the appropriate thickness of each of the pavement layers. The equations are used in a series of steps. First determine the *required structural number*, then *select layer thicknesses*, and finally apply a *layered design analysis*. Additional steps of evaluating staged construction alternatives and roadbed swelling shall be added to the design as needed. Each of these steps will be considered in the following sections of this guide.

**10.2.4.1 Determining Required Structural Number**

Flexible pavement design is based on determining a structural number (SN) that, given the subgrade conditions of the pavement, can withstand the projected number of ESALs. As mentioned earlier, this method is based on the 1993 AASHTO Design Guide, the structural number equation and design nomographs can be found in the 1993 AASHTO guide. And, in the past they had been acquired through commercially available design software packages such as AASHTO’s DARWin program. Note that the DARWin program is no longer available and it was replaced with the new AASHTO Pavement ME Design software. The MCDOT MEPDG (posted online) provides the ME (Mechanistic Empirical) design procedure.

The output of the 1993 AASHTO Design Guide calculations is the Design Structural Number (SN). The equation is as follows:

$$\log_{10}(W_{18}) = Z_R S_0 + 9.36 \log_{10}(SN + 1) - 0.2 + \frac{\log_{10}\left(\frac{\Delta_{PSI}}{4.2 - 1.5}\right)}{0.40 + \frac{1094}{(SN + 1)^{5.19}}} + 2.32 \log_{10}(M_R) - 8.07$$

Where,

- $W_{18}$  = Total accumulated traffic in ESALs for the design lane
- $S_0$  = Overall standard deviation
- $M_R$  = Effective roadbed soil resilient modulus
- $\Delta_{PSI}$  = Design serviceability loss
- $Z_R$  = Standard normal random variable

Structural number (SN) obtained from the above equation will be compared with the minimum structural number shown in Table 10.2.8 for the appropriate roadway type. The larger SN shall be used for pavement design.

<b>TABLE 10.2.8 MINIMUM STRUCTURAL NUMBER BASED ON ROADWAY TYPE</b>		
<i>Roadway Classification</i>		<i>SN (Min.)</i>
<i>Rural</i>	<i>Urban</i>	
Principal Arterial	Principal Arterial	2.88
Minor Arterial	Minor Arterial	2.88
Major Collector	--	2.46
--	Major Collector (Industrial/Commercial)	2.88
--	Major Collector (Residential)	2.13
Minor Collector	--	2.46
--	Minor Collector (Industrial/Commercial)	2.88
--	Minor Collector (Residential)	2.13
Local Road (Residential)	Local Road (Residential)	1.77
Local Road (Industrial/Commercial Subdivisions)	Local Road (Industrial/Commercial Subdivisions)	2.88

**10.2.4.2 Selection of Layer Thicknesses**

After the design structural number (SN) has been determined, develop layer thicknesses which, when combined, will provide the load carrying capacity to meet the design structural number. The following equation is used to accomplish this.

$$SN = a_1 D_1 + a_2 D_2 m_2 + a_3 D_3 m_3 + \dots$$

Where,

- $a_1, a_2, a_3$  = layer coefficients representative of surface, base, and subbase courses, respectively.
- $D_1, D_2, D_3$  = actual thicknesses of surface, base, and subbase courses, respectively.
- $m_2, m_3$  = drainage coefficients for unbound layers (base and subbase, respectively).

The designer can conceive various alternative combinations of layers and thicknesses that will achieve the required design structural number (SN). Several different combinations are to be developed. The final design recommendation will be made after these alternative combinations are evaluated based on:

1. Layered design analysis.
2. Evaluation of the expansion potential of the subgrade.
3. Construction cost analysis for the pavement.

### **10.2.4.3 Layered Design Analysis**

The pavement structure is a layered system and each underlying layer affects the layers above it. The design equation presented above can be used to evaluate the adequacy of each layer to support the layers above it. The minimum SN for the pavement structure above a particular layer may be computed using the AASHTO formula and the resilient modulus ( $M_R$ ) for that layer. The 1993 AASHTO guide (Page II-36) should be referred to for a more complete explanation of the layered analysis approach.

A layered design analysis does not change the design structural number, but affects limits on some of the layer thicknesses. The most common impact on pavement designs is that it requires thicker layers of asphalt concrete (AC) on roadways with high traffic volumes. A layered design analysis is required for MCDOT pavement designs.

#### **10.2.4.3.1 Construction Constraints for Layer Thickness**

The design thickness of asphalt concrete (AC) shall be rounded upward to the nearest ½-inch increment. The design thickness of granular aggregate base (AB) shall be rounded upward to the nearest 1-inch using a minimum layer thickness of 4-inches. The designed thickness of stabilized native or base shall be rounded upward to the nearest 1-inch with a minimum layer thickness of 6-inches. Refer to Table 10.2.6 for thickness constraints adopted by MCDOT.

For constructability, the design asphalt concrete layer thicknesses should be subdivided into thicknesses complying with MAG Table 710-1 (Recommended Lift Thickness For Asphalt Concrete Mixes).

#### **10.2.4.4 Expansive and Collapsible Soils**

Expansive soils in the roadway subgrade are detrimental to pavement performance in several ways. The resilient modulus of expansive soils is generally very low, expansion of the subgrade can reduce the ride quality and decrease the pavement's serviceability ratings, and differential movements can crack the pavement and propagate local failures causing increased maintenance costs. The pavement design process will incorporate the following measures in consideration of these detrimental effects.

Subgrade soils having a plasticity index ( $PI$ ) above 15 with more than 20% passing the No. 200 sieve ( $P_{200}$ ) shall be considered potentially expansive. The engineer shall take additional samples or test existing samples as necessary to ensure that a minimum of 3 samples of any potentially expansive soil are tested. The treatment described in Table 10.2.9 will then be required based on the average of the three samples with the highest expansion potential. If it is not possible to obtain 3 samples representing a given expansive soil, the treatment given in Table 10.2.9 will be based on the test result of the sample with the highest expansion potential.

This method for treatment of swelling soils is a modification of a method presented in Section 313 of the Airport Pavement Design and Evaluation Manual published by the Federal Aviation Administration (FAA)<sup>5</sup>. That method establishes prescribed treatments of subgrade soils based on their expansion potential as measured in the CBR test (ASTM D1883).

The guidelines presented here have established similar prescribed treatments, but the level of treatment is based on one-dimensional expansion potential test results. Samples for expansion tests shall be re-molded in accordance with ARIZ 249 (ADOT Materials Testing Manual) to 95% of maximum dry density and at 2% below optimum moisture as determined by ASTM D698 and tested for one-dimensional expansion in accordance with the applicable portions of ASTM D4546 applying a surcharge of 144 psf. At the discretion of the pavement designer, the surcharge load can be adjusted to match the overburden produced by a reasonable estimate of the proposed design pavement section. Testing and calculation of swell pressures will not be required.

An alternative to the prescribed treatments is to remove the subgrade soils to a depth of 24 inches below the bottom of base course and replace with a non-expansive and otherwise suitable soil.

Some sandy-silty soils exhibit high level of collapsibility due to wetting. In some cases, in-place densities are low and at the same time show low dry strength and the soils are identified as loose or very loose. In both of the above cases, over-excavation and re-compaction should be considered.

<b>TABLE 10.2.9 – RECOMMENDED TREATMENT FOR SWELLING SUBGRADE SOILS</b>	
<b>Expansion Potential</b>	<b>Recommended Treatment</b>
< 2%	None
2% to 5%	Stabilize <sup>a</sup> in place to a depth of 6 inches
> 5%	Stabilize <sup>b</sup> with lime to a depth of 12 inches
<p><sup>a</sup> The soil can be stabilized with either lime, cement or lime/cement combination by specifying the requirements of MAG Section 309 Lime Slurry Stabilization or MAG Section 311 Soil Cement Base Course. For either method, a minimum compressive strength of 160 psi shall be achieved when tested as required by the specifications.</p> <p><sup>b</sup> The soil should be stabilized with lime in at least two layers following the requirements of MAG Section 311. The bottom layer can be stabilized in place.</p>	

Some silty sand or sandy silt soils have a high  $P_{200}$  but are non-plastic. Such soils are usually sensitive to moisture content and are difficult to compact into a firm grade. In such case, soil cement base may be considered.

**10.2.4.5 Construction Cost Analysis**

The pavement designer shall consider different pavement structures and their comparable costs. As an example, the designer may consider the following three alternatives for a given pavement design:

- Full Depth Asphalt Concrete (AC only)
- Asphalt Concrete (AC) over aggregate base (AB)
- Asphalt Rubber (AR) over Asphalt Concrete (AC) over aggregate base (AB)

The layer thicknesses are to be calculated for each alternative to achieve the design structural number required for that project. Then cost estimates for each alternative are to be prepared. The most economical alternative should be given consideration in selecting the recommended alternative. Factors such as constructability, re-use of existing materials, and noise reduction shall be considered in the evaluation and recommendations.

Cost estimates on a minimum of three alternatives shall be prepared for all MCDOT pavement designs except for local roads and minor collectors. Additionally, the design engineer shall make a recommendation of which alternative they believe to be most advantageous to the project.

### **10.2.5 ALTERNATIVE DESIGN METHOD FOR LOCAL AND MINOR COLLECTOR ROADS**

For local and minor collector roads, an alternative simple design procedure is available to pavement designers. This method utilizes *Sieve* and *PI* data to evaluate the subgrade and does not require traffic analysis except as necessary to determine the roadway classification.

#### **10.2.5.1 Sampling**

Test holes for the soils investigation segment of the pavement design shall be within the pavement alignment, and shall be spaced at one (1) per eight hundred (800) lineal feet with at least one per proposed street. Each test hole shall be advanced to 24 inches below the elevation of proposed subgrade if there is no significant cut or fill required. In areas of cut or fill, the Engineer shall use his professional judgment to determine the depth of each test hole. The intent of the test hole depth is to achieve a minimum of 2 feet of the final roadway's subgrade materials sampled and tested. Additional test holes shall be taken at apparent changes in soil type.

#### **10.2.5.2 Testing and Design**

As a minimum, at least one soil sample from each test hole shall be tested for sieve analysis (AASHTO T27) and *PI* (AASHTO T89 & T90). Resulting test values of *PI* and  $P_{200}$  are then used in design Charts 100A, 100B, 200A, and 200B to determine the base requirements of the asphalt pavement structural section. Table 10.2.10 provides a guide to each chart.

If a soil sample exhibits *PI* greater than 15 with  $P_{200}$  greater than 20, then an expansive potential test shall be performed in accordance with Section 10.2.4.4. If the expansion potential is equal to or greater than 2 percent, use Design Charts 100B and 200B to determine the base requirements of the asphalt pavement structural section.

All asphalt concrete pavement of local and minor collector roads with a longitudinal grade less than 5% shall receive a preservative seal ("filled" asphalt sealer) in accordance with Sections 334 and 718.3 of the MAG Uniform Standard Specifications.

<b>TABLE 10.2.10 DESIGN CHARTS SUMMARY FOR LOCAL &amp; MINOR COLLECTOR ROADS</b>			
<b>Road Classification</b>	<b>Subgrade Type</b>	<b>Minimum AC Thickness</b>	<b>Minimum AB or AB/LSS Thickness</b>
Minor Collector	Non-Expansive	3.0 in.	See Chart 100A
	Expansive	3.0 in.	See Chart 100B
Local	Non-Expansive	2.5 in.	See Chart 200A
	Expansive	2.5 in.	See Chart 200B

The designer has two options for determining the design values of PI and  $P_{200}$ :

### Option 1:

The first option is to plot all of the test sample values of PI and  $P_{200}$  and then select the sample resulting in the highest thickness of base course. This option shall always be used if fewer than 5 samples are used in the design.

### Option 2:

The second option is to use a weighted average approach. This approach can be accomplished with the following steps:

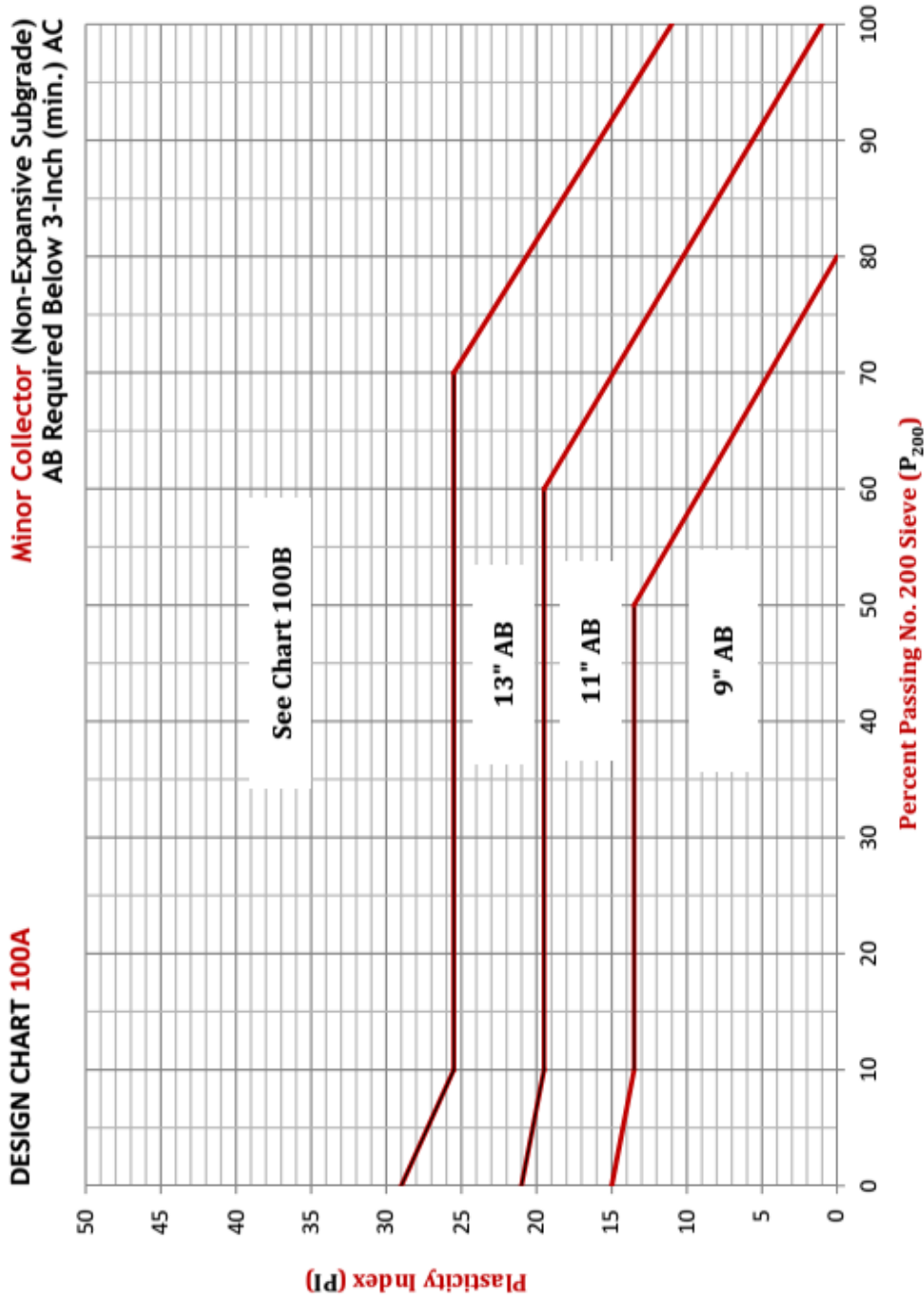
- Summarize all of  $P_{200}$  and PI data on a chart along with calculated estimates for R-value and Resilient Modulus ( $M_R$ ) using the formulas presented in Section 10.2.2.1.1. Standard deviations for each parameter shall be presented on the summary chart as shown on the example in Table 10.2.11.
- When the chart is completed, the engineer will be able to identify if more than one pavement section would be beneficial for the project. If more than one section will be designed, each section is to have a separate chart summarizing the test results applicable to that design.
- Use the summary chart to determine the weighted average values for PI and  $P_{200}$ . The weighting will tend to place more emphasis on the poorer soils rather than the better soils, and will not allow excessive variation from the average to the poorest soils encountered. Eliminating the test samples with the highest resilient modulus values one at a time until the standard deviation of the remaining resilient modulus values is less than 8,000 psi produces the weighted average. The  $P_{200}$  and PI results from these “remaining” samples are then used to calculate the weighted average.
- Calculate the weighted average values for  $P_{200}$  and PI by adding one standard deviation to their remaining averages. The adjustments made following the above three steps are shown in Table 10.2.12.
- Plot these weighted average values on Design Chart Series 100 or 200 to determine the required base course thickness to go with the predetermined asphalt concrete thickness.

- Design Chart Series 100 & 200 that consist of four charts are included after the following two tables.

<b>TABLE 10.2.11 TEST DATA SUMMARY</b>				
<b>Test Hole No.</b>	<b>PI</b>	<b>P<sub>200</sub></b>	<b>Correlated R-value (psi)</b>	<b>Resilient Modulus (psi)</b>
1	8	39	42.7	26,301
2	11	50	32.6	19,491
3	19	41	27.0	16,053
4	17	30	34.0	20,375
5	16	31	34.8	20,941
6	33	75	9.7	7,061
7	34	77	9.1	6,778
8	30	72	11.4	7,833
9	9	21	52.6	33,818
10	15	16	44.6	27,681
11	15	12	47.1	29,559
12	12	12	53.0	34,109
13	6	6	72.8	51,503
14	12	18	48.8	30,815
15	21	46	23.3	13,923
16	21	49	22.3	13,396
17	20	13	38.2	23,183
18	12	12	53.0	34,109
19	15	13	46.5	29,075
Average	17	33	37	23,474
St Dev	8	23	17	11,400 <sup>a</sup>
Avg. + St Dev	25	56	<sup>a</sup> Note: Since 11,400 is greater than 8,000, eliminate data, beginning with the highest Resilient Modulus, one test hole at a time, until the standard deviation of the resilient modulus values is less than 8,000.	

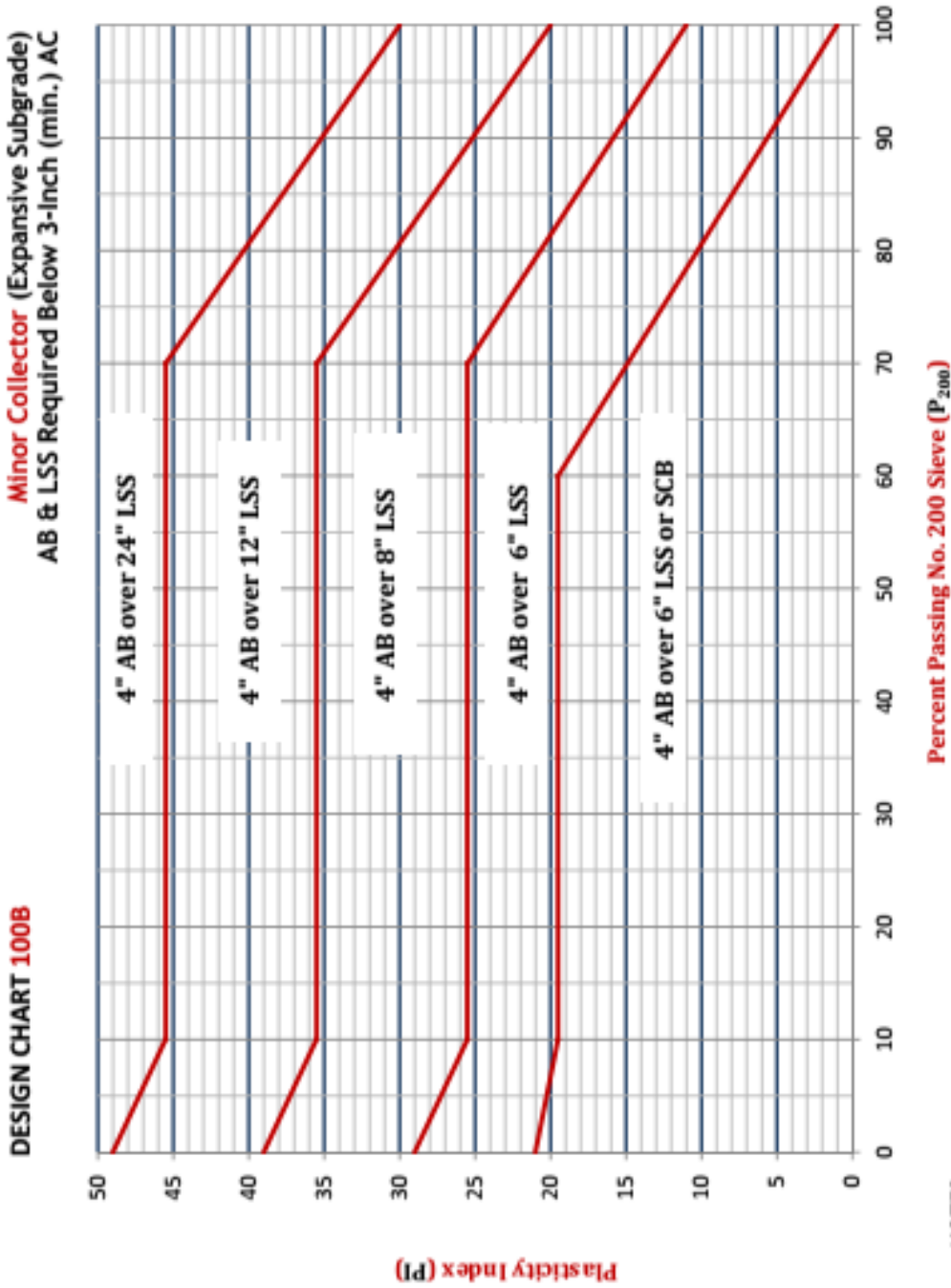
<b>TABLE 10.2.12 TEST DATA SUMMARY–WITH WEIGHTED AVERAGE</b>				
<b>Test Hole No.</b>	<b>PI</b>	<b>P<sub>200</sub></b>	<b>Correlated R-value (psi)</b>	<b>Resilient Modulus (psi)</b>
1	8	39	42.7	26,301
2	11	50	32.6	19,491
3	19	41	27.0	16,053
4	17	30	34.0	20,375
5	16	31	34.8	20,941
6	33	75	9.7	7,061
7	34	77	9.1	6,778
8	30	72	11.4	7,833
9				
10	15	16	44.6	27,681
11				
12				
13				
14	12	18	48.8	30,815
15	21	46	23.3	13,923
16	21	49	22.3	13,396
17	20	13	38.2	23,183
18				
19				
Average	20	43	29	17,987
St Dev	8	22	13	7,962 <sup>a</sup>
Avg. + St Dev <b>(Weighted Avg.)</b>	28	65	<sup>a</sup> Note: Six test holes were eliminated from the data to bring the standard deviation of resilient modulus to less than 8,000.	

**DESIGN CHART 100A**  
 Depth of Aggregate Base for Minor Collector  
 Non-Expansive Subgrade



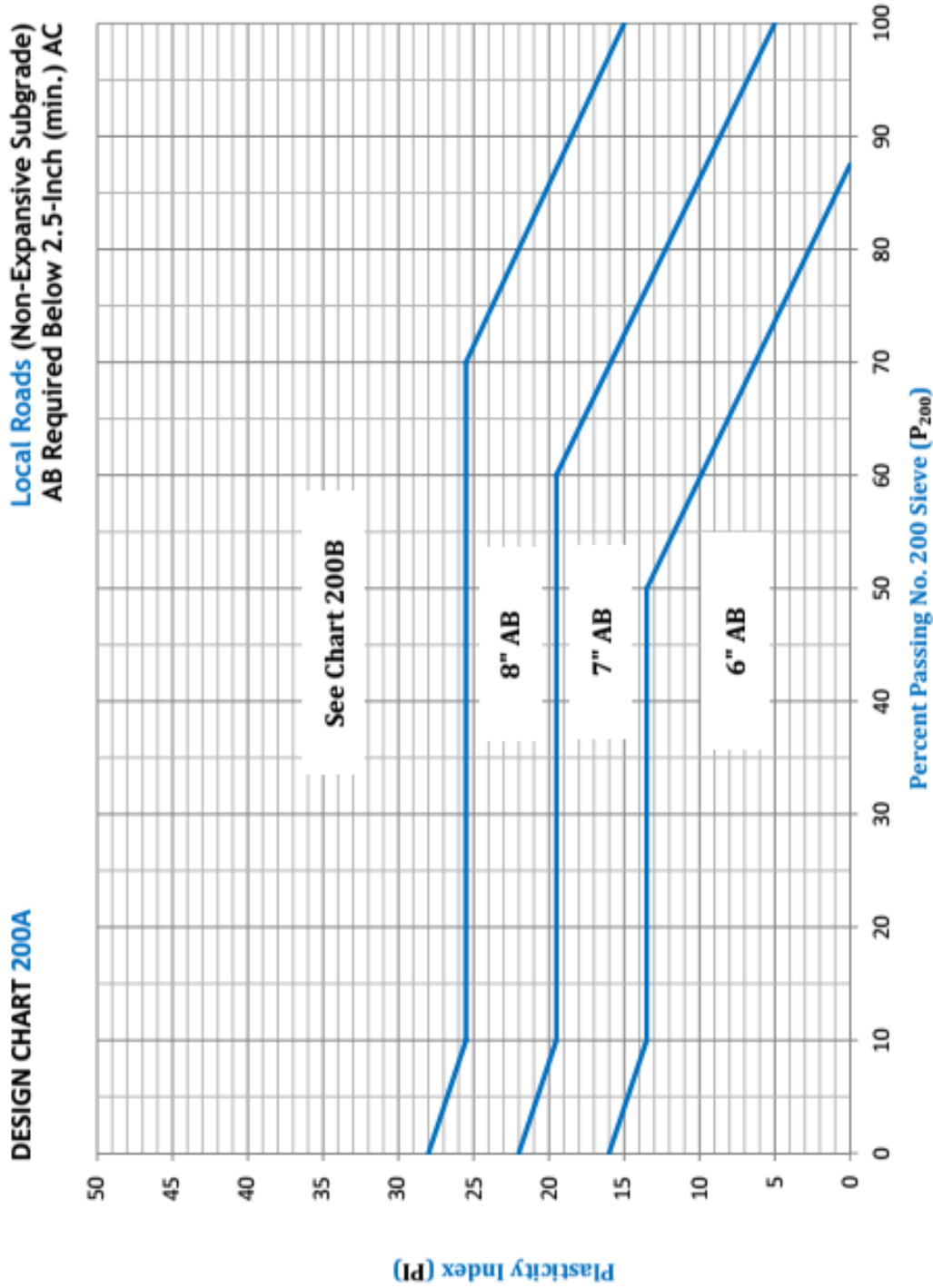
- NOTES:**
- (1) AB = Aggregate Base course (MAG 702.2).
  - (2) Subgrade for all curb, gutter, and attached sidewalk shall be stabilized to match stabilization depth of pavement section.
  - (3) This detail is also applicable for industrial/commercial roads with 4" (minimum) of asphalt concrete.

**DESIGN CHART 100B**  
 Depth of Aggregate Base for Minor Collector  
 Expansive Subgrade



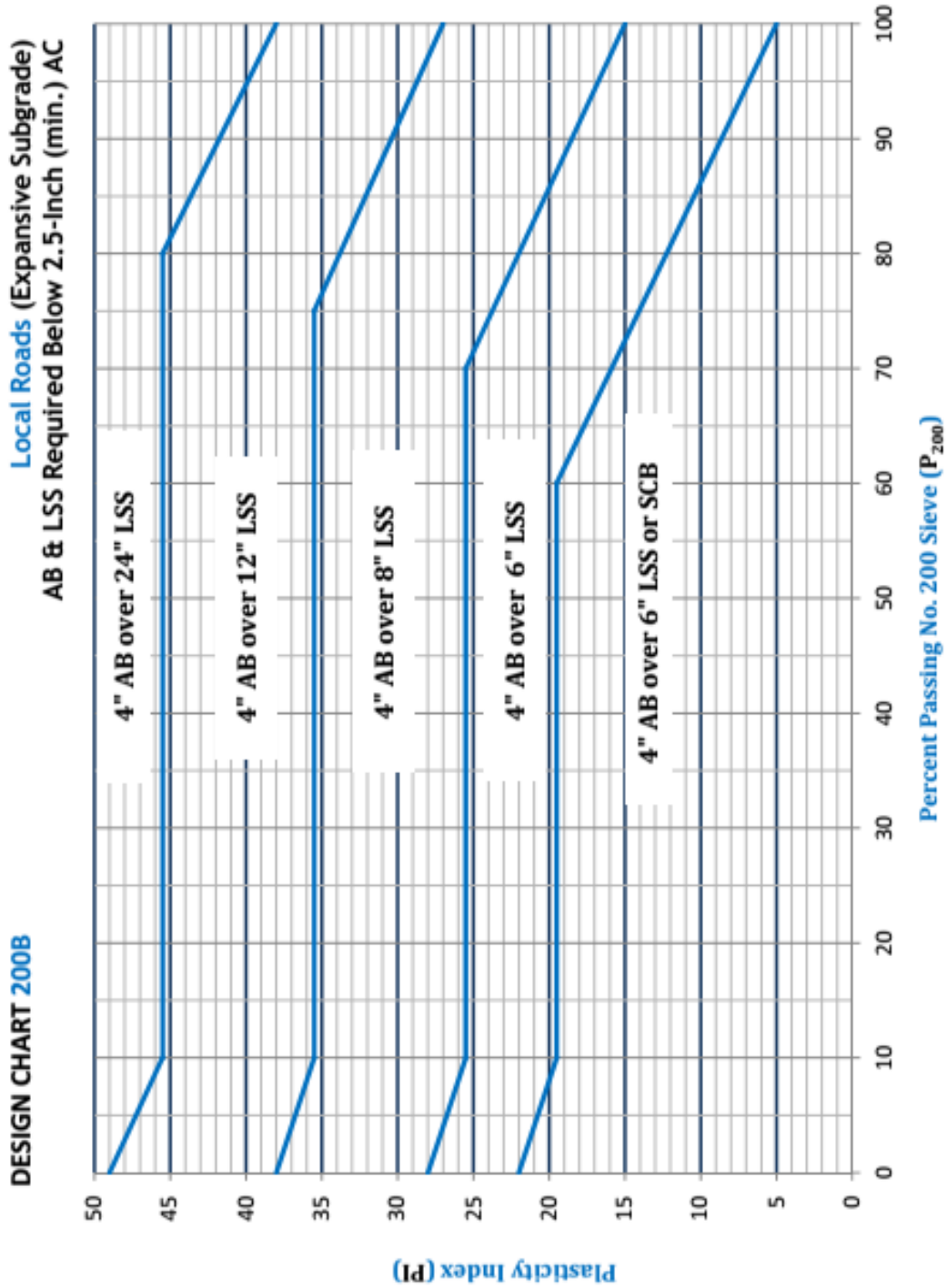
- NOTES:**
- (1) AB = Aggregate Base course (MAG 702.2).
  - (2) LSS = Lime Slurry Stabilized Subgrade (MAG 309).
  - (3) SCB = Soil Cement Base (MAG301).
  - (4) Subgrade for all curb, gutter, and attached sidewalk shall be stabilized to match stabilization depth of pavement section.
  - (5) This detail is also applicable for industrial/commercial roads with 4" (minimum) of asphalt concrete.

**DESIGN CHART 200A**  
 Depth of Aggregate Base for Local Roads  
 Non-Expansive Subgrade



- NOTES:**
- (1) AB = Aggregate Base course (MAG 702.2).
  - (2) CLSS = Cement or Lime Stabilized Subgrade (MAG 311 or 309).
  - (3) Subgrade for all curb, gutter, and attached sidewalk shall be stabilized to match stabilization depth of pavement section.
  - (4) This detail is also applicable for industrial/commercial roads with 4" (minimum) of asphalt concrete.

**DESIGN CHART 200B**  
 Depth of Aggregate Base for Local Roads  
 Expansive Subgrade



**10.2.6 RIGID PAVEMENT DESIGN**

Rigid pavement (Portland Cement Concrete Pavement) sections are occasionally designed for MCDOT roadways when the flexible pavement sections are not adequate for certain situations. For example, concrete pavement sections are used on bus bays or when the truck percentage on a road section is relatively high.

Rigid pavement design shall be in accordance with the procedure shown in Chapter 2 of the latest revision of ADOT Pavement Design Manual<sup>1</sup>. The basic design equation for rigid pavements given in ADOT’s manual is:

$$\log_{10}(W_{18}) = Z_R S_0 + 7.35 \log_{10}(D + 1) - 0.06 + \frac{\log_{10} \left( \frac{\Delta \text{PSI}}{4.5 - 1.5} \right)}{1 + \frac{1.624 \times 10^7}{(D + 1)^{8.46}}} + (4.22 - 0.32 p_t) \log_{10} \left[ \frac{S'_c C_d (D^{0.75} - 1.132)}{215.63 J \left( D^{0.75} - \frac{18.42}{(E_c/k)^{0.25}} \right)} \right]$$

Where,

- $W_{18}$  = predicted number of 18-kip equivalent single axle load applications
- $Z_R$  = standard normal deviate
- $S_0$  = combined standard error of the traffic prediction and performance prediction, equal to 0.35
- $D$  = thickness (inches) of pavement slab, cannot be less than nine (9) inches
- $S'_c$  = average modulus of rupture (psi) for Portland cement concrete used on a specific project, fixed at 670 psi
- $p_0$  = design initial serviceability index
- $p_t$  = design terminal serviceability index
- $\Delta \text{PSI}$  =  $p_0 - p_t$
- $C_d$  = drainage coefficient same as flexible
- $J$  = load transfer coefficient used to adjust for load transfer characteristics of a specific design
- $E_c$  = modulus of elasticity (psi) for concrete. It can be estimated from concrete compressive strength  $f'_c$ :

$$E_c = 57000(f'_c)$$

- $k$  = modulus of subgrade reaction is found by first determining the subgrade Resilient Modulus,  $M_R$  (see flexible pavement design). For full depth design  $M_R$  can be converted to  $k$  value with the following formula:

$$k = \frac{M_R}{19.4}$$

**QUICK REFERENCE**

**Pavement Design Procedures**

1. Standard Analysis Period: 20 Years
2. Directional Distribution:  $D_D = 0.5$  to 0.7 (normally 0.5)
3. Lane Distribution:  $D_L$

Number of Lanes in Each Direction	Percent of 18-kip ESALs in Design Lane ( $D_L$ )
1	100
2	90
3	70
4	60

4. Reliability:

Functional Classification <sup>a</sup>	Reliability	$Z_R$ Value	Std. Dev. ( $S_0$ )
Highways and Parkways	95 %	-1.645	0.45
Arterials & Industrial	95 %	-1.645	0.45
Collectors	90 %	-1.282	0.45
Residential (Local)	80 %	-0.841	0.45

<sup>a</sup> See Chapter 2 for *Functional Classification* Definitions.

5. Serviceability:

Functional Classification <sup>a</sup>	$P_0$	$P_t$	$\Delta_{PSI}$
Highways and Parkways	4.6	2.7	1.9
Arterials & Industrial	4.5	2.5	2.0
Collectors	4.4	2.3	2.1
Residential (Local)	4.2	2.0	2.2

<sup>a</sup> See Chapter 2 for *Functional Classification* Definitions.

6. Overall Standard Deviation:  $S_0 = 0.45$
7. Soil Resilient Modulus (refer to formulas in Section 10.2.2)

8. Structural Layer Coefficient:

Material Description	Structural Layer Coefficient, $a_i$	Thickness Constraint
Asphalt Rubber Asphalt Concrete (ARAC)	0.42 <sup>a</sup>	Minimum 1.5 in. <sup>b</sup> Maximum 2.0 in.
Asphalt Concrete (AC)	0.42	Based on Layered Analysis
Cement Treated Base (CTB)	0.28	Minimum 4.0 in.
Aggregate Base (AB)	0.12	Minimum 4.0 in.
MAG Select	0.11	Minimum 4.0 in.
Stabilized Subgrade	0.16 to 0.23 <sup>c</sup>	Minimum 6.0 in.

<sup>a</sup> In order to consider the superior performance in resistance to cracking and other aging characteristics, a structural layer coefficient of 0.61 may be used for ARAC only for 1.5-in. thickness (as specified in MAG Sections 325 and 717) when used as a surface course on top of 3 inches or greater of conventional asphalt pavement (as specified in MAG Sections 321 and 710).

<sup>b</sup> Minimum thickness can be reduced to 1.0 inch for hot-in-place recycling (HIPR) pavement construction.

<sup>c</sup> The coefficient for stabilized subgrade is to be determined using a non-soaked 7-day compressive strength, using ASTM D1633 Method A, and the following formula:

$$a_i = 0.15 + 0.0001 (\text{CSCLS})$$

Where: CSCLS = Compressive strength of cement or lime stabilized subgrade in psi.

9. Drainage Coefficient:

Drainage Quality	Drainage Coefficient ADOT <sup>1</sup>	Water Removed Within AASHTO <sup>2</sup> , page II-22
Excellent	1.15	2 hours
Good	1.07	1 day
Fair	1.00	1 week
Poor	0.93	1 month
Very Poor	0.86	Water will not drain

10. Expansion Potential:

<b>Expansion Potential</b>	<b>Recommended Treatment</b>
< 2%	None
2% to 5%	Stabilize <sup>a</sup> in place to a depth of 6 inches
> 5%	Stabilize <sup>b</sup> with lime to a depth of 12 inches
<p><sup>a</sup> The soil can be stabilized with either lime, cement or lime/cement combination by specifying the requirements of MAG Section 309 Lime Slurry Stabilization or MAG Section 311 Soil Cement Base Course. For either method, a minimum compressive strength of 160 psi shall be achieved when tested as required by the specifications.</p> <p><sup>b</sup> The soil should be stabilized with lime in at least two layers following the requirements of MAG Section 311. The bottom layer can be stabilized in place.</p>	

## 10.3 ECONOMIC EVALUATION OF ALTERNATIVE PAVEMENT DESIGN STRATEGIES (LIFE CYCLE COST ANALYSIS)

### Originator: Construction and Materials Division

Each pavement design for County contracted work shall contain an economic comparison of at least three alternative pavement design strategies. Earthwork associated with stabilization is to be included as part of the stabilization cost. General earthwork volumes and cost should be excluded from the analyses.

A table presenting typical prices for some of the anticipated pavement materials is shown below. Prices in the table are representative of MCDOT construction projects between 2019 and 2022. Cost factors may need to be adjusted for proposed construction dates and project specific conditions and materials.

<b>Prices for Pavement Materials</b>						
Item	Price Basis				Unit Wt. (pcf)	Factor (sy/in/ton)
	Cost (\$/sy/in)		Cost (\$/ton)			
	low	high	low	high		
PMTR AC	\$6.92	\$7.99	\$130.00	\$150.00	142	19.46
Asphalt Concrete (½-in.)	\$6.53	\$7.67	\$120.00	\$140.00	145	18.39
Asphalt Concrete (¾-in.)	\$6.57	\$7.67	\$120.00	\$140.00	145	18.39
Asphalt Rubber Concrete (½-in.)	\$6.68	\$8.211	\$130.00	\$150.00	137	19.46
Soil Cement Base (3-4% cement)	\$1.00	\$1.81			130	20.51
Lime Stabilized Subgrade (5% lime)	\$0.70	\$0.80			125	21.33
Asphalt Milling (1-in. to 3-in.)	\$1.70	\$2.00	\$33.50	\$39.50	135	19.75
Asphalt Milling (3-in. to 6-in.)	\$2.00	\$2.70	\$39.50	\$53.40	135	19.75
Asphalt Pulverizing (> 4-in.)	\$1.00	\$1.00				
Item	Price Basis				Unit Wt. (pcf)	Factor (sy/in/ton)
	Cost (\$/sy/in)		Cost (\$/cy)			
	low	high	low	high		
Aggregate Base Course	\$4.00	\$5.67	\$48.00	\$68.00	135	36.00

**10.3.1 EXAMPLE PAVEMENT DESIGN COST ASSESSMENT FOR PRELIMINARY PAVEMENT DESIGN**

For preliminary pavement designs, such as for a Scoping and Design Report, alternative cost estimates are to be prepared on the basis of cost per square yard as shown in the example below. The intent of these estimates is to provide sufficient cost comparisons to compare the various pavement design alternatives.

<b>Alternate 1: Reconstruction with 1.5-inch PMTR AC</b>			
<b>Layer</b>	<b>Thickness (in.)</b>	<b>Cost/sy/in</b>	<b>Cost/sy</b>
PMTR AC	1.5	\$7.46	\$11.19
Bituminous Tack Coat SS-1h, Diluted (0.07 gal/sy)	-	-	\$0.42
Asphalt Concrete (¾-in.)	3.0	\$7.12	\$21.36
Asphalt Pulverizing (1-in. to 4-in.)	4.0	\$1.00	\$4.00
<b>Total</b>			<b>\$36.97</b>

<b>Alternate 2: Reconstruction with 5-inch AC</b>			
<b>Layer</b>	<b>Thickness (in.)</b>	<b>Cost/sy/in</b>	<b>Cost/sy</b>
Asphalt Concrete (½-in.)	2.0	\$7.45	\$14.90
Bituminous Tack Coat SS-1h, Diluted (0.07 gal/sy)	-	-	\$0.42
Asphalt Concrete (¾-in.)	3.0	\$7.45	\$22.35
Asphalt Pulverizing (1-in. to 4-in.)	4.0	\$1.00	\$4.00
<b>Total</b>			<b>\$41.25</b>

<b>Alternate 3: 2-inch AC and 2-inch PMTR AC Double Overlay</b>			
<b>Layer</b>	<b>Thickness (in.)</b>	<b>Cost/sy/in</b>	<b>Cost/sy</b>
PMTR AC	2.0	\$7.46	\$14.92
Bituminous Tack Coat SS-1h, Diluted (0.07 gal/sy)	-	-	\$0.42
Asphalt Concrete (½-in.)	2.0	\$7.12	\$14.24
Asphalt Milling	1.0	\$1.85	\$1.85
<b>Total</b>			<b>\$31.01</b>

<b>Alternate 4: 3-inch AC Structural Overlay</b>			
<b>Layer</b>	<b>Thickness (in)</b>	<b>Cost/sy/in</b>	<b>Cost/sy</b>
Asphalt Concrete (½in.)	3.0	\$7.45	\$22.35
Asphalt Milling	1.0	\$1.85	\$1.85
<b>Total</b>			<b>\$24.20</b>

**10.3.2 EXAMPLE PAVEMENT DESIGN COST ASSESSMENT FOR FINAL DESIGN**

Final pavement design alternative cost estimates shall be prepared on the basis of cost per lane mile of pavement. A lane mile of pavement shall be considered as 15-foot wide by 5280-feet long. This more detailed cost estimate is to assist the project designer in establishing the appropriate pavement pay quantities to include in the bid documents. The pavement construction items are to reference the MCDOT bid item number and description when an appropriate bid item exists in the MCDOT listings. Assumptions such as material density or application rates shall be included in the estimates. The pavement designer shall review the list of bid items to determine which standard specifications will apply and if special provisions need to be written for any of the pavement bid items. If special provisions are needed, they shall be included in the report. Example cost estimates for final pavement designs are presented below.

<b>Alternative 1: AC and AB over Native Subgrade</b>				
<b>Pavement Construction Item</b>	<b>Unit</b>	<b>Quantity</b>	<b>Unit Price</b>	<b>Cost per lane-mile</b>
<b>321.02202</b> PMTR AC Pavement (Superpave 1/2 in High Traffic), 1.5" @ 142 pcf	ton	678	\$ 140.00	\$94,920
<b>321.01300</b> Asphalt Concrete Pavement (Superpave 3/4" Mix, High Traffic), 3" depth @ 145pcf	ton	1,436	\$ 130.00	\$186,680
<b>329.01000</b> Bituminous Tack Coat SS-1h, Diluted @ (0.07 gal/sy)	ton	3	\$1,500.00	\$4,500
<b>310.03001</b> Aggregate Base Course	cy	2,828	\$ 58.00	\$170,114
<b>Total Cost per lane-mile</b>				<b>\$456,214</b>

<b>Alternative 2: AC and AB over Lime Stabilized Subbase</b>				
<b>Pavement Construction Item</b>	<b>Unit</b>	<b>Quantity</b>	<b>Unit Price</b>	<b>Cost per lane-mile</b>
<b>321.02202</b> PMTR AC Pavement (Superpave 1/2 in High Traffic), 1.5" @ 142 pcf	ton	678	\$ 140.00	\$94,920
<b>321.01300</b> Asphalt Concrete Pavement (Superpave 3/4" Mix, High Traffic), 3" depth @ 145pcf	ton	1,436	\$ 130.00	\$186,680
<b>329.01000</b> Bituminous Tack Coat SS-1h, Diluted @ (0.07 gal/sy)	ton	3	\$1,500.00	\$4,500
<b>310.03000</b> Aggregate Base Course, 4" @ 135 pcf	cy	943	\$ 58.00	\$54,694
<b>309.02000</b> Lime (CaO and MgO), 30 lbs/sy	ton	132	\$350.00	\$46,200
<b>309.01006</b> Lime Stabilized Subgrade, 6" Depth	sy	8,800	\$ 4.50	\$39,600
<b>Total Cost per lane-mile</b>				<b>\$477,280</b>

<b>Alternative 3: Full Depth AC over Native Subgrade</b>				
<b>Pavement Construction Item</b>	<b>Unit</b>	<b>Quantity</b>	<b>Unit Price</b>	<b>Cost per lane-mile</b>
<b>321.02202</b> PMTR AC Pavement (Superpave 1/2 in High Traffic), 1.5" @ 142 pcf	ton	678	\$ 140.00	\$94,920
<b>321.01300</b> Asphalt Concrete Pavement (Superpave 3/4" Mix, High Traffic), 6" depth @ 145pcf	ton	2,872	\$ 130.00	\$373,360
<b>329.01000</b> Bituminous Tack Coat SS-1h, Diluted @ (0.07 gal/sy)	ton	6	1,500.00	\$9,000
<b>Total Cost per lane-mile</b>				<b>\$477,280</b>

## **10.4 SPECIFICATIONS**

### **Originator: Construction and Materials Division**

The preliminary pavement design report shall provide descriptions of each of the materials used in the design. Final pavement design reports shall have a list (can be part of the cost estimate) of the pavement construction items to be used. Specifications shall be provided for any materials or processes to be used that are not included in MAG or the MCDOT Supplement to MAG.

Pavement designs that have a possibility of requiring fill beneath the roadway shall include a section describing the requirements for the soils to be allowed in the fill. The “Subgrade Acceptance Chart” developed by ADOT is one method of identifying soil requirements for pavements. These charts are discussed in ADOT Pavement Design Manual<sup>1</sup>.

If expansive soils are encountered in subgrade soils, final pavement design reports shall include a construction specification that describes the recommended remedy. Such specifications shall address treatment of soils beneath curb, gutter and sidewalk as well as pavements, and shall clearly state that the specification applies to soils beneath curb, gutter, and sidewalk.

## **10.5 REPORTING REQUIREMENTS**

### **Originator: Construction and Materials Division**

This section deals with the documentation and presentation of the information developed during the design process. Results of the pavement design and analysis shall be presented in a written report that clearly describes the Engineer's approach to prior sections of this manual. All calculations, assumptions, and test results shall be clearly reported. Section 203 (Design Documentation and Presentation) of the ADOT's Pavement Design Manual<sup>1</sup> shall be used as a guide, except that typically no discussion or investigation of material pits will be necessary.

#### **10.5.1 PAVEMENT DESIGN REPORT**

A pavement design report is prepared for each project to show the basis for the proposed design. It provides information necessary for review of the design and supports the design recommendations.

The pavement design report shall include the description, location, and reason for a project. Visual observations made by the designer shall be listed. Subsoil conditions and geology shall be discussed and test results pertinent to the design such as R-values, PI, gradation, moisture, pH and resistivity are to be documented.

For reconstruction or new construction, the selection of the design resilient modulus value is to be discussed. Other factors important in the design shall be listed including traffic loading, drainage coefficients, and the sources for information used in the design. If the project is to be divided into sections with different design recommendations, support shall be shown for this division, such as, different soil type, different traffic loading, or different existing pavement conditions.

The pavement design report shall list different design alternatives, an economic cost comparison and a discussion explaining the reason for each alternative chosen. Unit costs and total costs are to be listed for each design considered.

Each pavement design report shall present a minimum pavement section for construction or temporary traffic. This design will typically use a 4-year analysis period. The design shall use the same base structure as the recommended section, but will omit at least the surface course.

The pavement design report is to give the recommended pavement structure and reasoning for selecting one alternate over the others. A supporting argument for the design chosen shall be presented.

An outline of information needed in the pavement design report is given in the next section.

## 10.5.2 OUTLINE OF PAVEMENT DESIGN REPORT

### **Introduction**

- A. Purpose of the report
- B. Location (include limits)
- C. Description and background of project
- D. Scope of investigation and analysis work
  - 1. Field investigation
  - 2. Laboratory analysis

### **Site Conditions and Visual Observations**

- A. Narrative description of the general geology of the project area as well as observed project specific geologic features.
- B. Pavement condition (list observed distresses and ride quality).
- C. Observed terrain and drainage conditions.
- D. Unusual conditions. (low bridge clearances, cattle guards, railroad crossings, equipment crossings, utilities, curb and gutter, guardrail height, etc.)

### **Geotechnical Profile and Soils Conditions**

- A. Logs of test borings, a site plan showing their locations and a description of procedures and equipment used in the boring program.
- B. Results of laboratory tests and a description of test methods.
- C. Description of the soil conditions encountered and the geotechnical profile of the site.

### **Design Analysis and Discussion**

- A. List of values used in design equation and an explanation of their origin (traffic  $W_{18}$ , reliability, effective resilient modulus  $M_R$ ,  $Z_R$ ,  $S_0$ ,  $PSI$  etc.)
- B. Description and discussion of alternate designs considered as well as construction costs. List SN required, component layer coefficients, drainage coefficient, seasonal variation factor, costs, special considerations, etc.
- C. Description of any computer programs used for analysis.
- D. Description of any assumption made that is not given in the MCDOT Pavement Design Guide.

### **Recommendations**

- A. Pavement section recommended and reasons for selection.
- B. Graphic sections or drawings of the recommended pavement sections to illustrate the intention of the design engineer. The section shall include a description of the pavement materials recommended for each of the pavement lifts.
- C. Discussion of pavement components, special considerations, and pavement surface treatment selection.
- D. Specification modifications.

### **Submittal Requirements**

- A. The report is to be sealed and signed by a Professional Engineer registered in the state of Arizona with specialized training and experience in pavement design.
- B. In addition to submittal of standard reports with original professional engineer seals and signature, the entire report including cover with signed professional seal, text, photos, engineering and other drawings, tables, maps, all appendices, and hand calculations shall be electronically submitted to MCDOT as one Acrobat Reader (pdf) file, suitable for publishing on the MCDOT website.

## **10.6 CHAPTER REFERENCES**

### **Originator: Construction and Materials Division**

<sup>1</sup>Arizona Department of Transportation (ADOT) *Pavement Design Manual*, Arizona Department of Transportation, Phoenix, Arizona September 2017.

<sup>2</sup>American Association of State Highway and Transportation Officials (AASHTO) *AASHTO Guide for Design of Pavement Structures*, Association of State Highway and Transportation Officials, Washington D. C. 1993.

<sup>3</sup>*Implementation of the AASHTO Mechanistic-Empirical Pavement Design Guide and Software*, National Cooperative Highway Research Program (NCHRP), 2014.

<sup>4</sup>Arizona Department of Transportation (ADOT) *Materials Preliminary Engineering and Design Manual*, Arizona Department of Transportation, Phoenix, Arizona March 1989.

<sup>5</sup>Federal Aviation Administration (FAA) Advisory Circular No. 150/5320-6E *Airport Pavement Design and Evaluation*, United States Department of Transportation, Washington, D.C. Dated 9/30/2009.

<sup>6</sup>Arizona Department of Transportation (ADOT) *Materials Testing Manual*, Arizona Department of Transportation, Phoenix, Arizona November 2, 2016.